



Operators Manual

MAJOR CONTOURA ROLLERMOWER

MJ75-360



Head Office

Major Equipment Intl. Ltd.
Ballyhaunis,
Co. Mayo,
Ireland.

Tel.: +353 (0) 9496 30572
Fax: +353 (0) 9496 30788
Email: info@major-equipment.com

UK Office

Major Equipment Ltd.
Major Industrial Estate,
Middleton Rd.,
Heysham,
Lancs.
LA3 3JJ

Tel.: +44 (0) 1524 850 501
Fax: +44 (0) 1524 850 502
Email: ukinfo@major-equipment.com

NETHERLANDS & GERMANY OFFICE

Major Equipment Intl. Ltd.
Postbus 29,
NL-7700 AA ,
Dedemsvaart,
Nederland.

Tel: +31 (0) 6389 19585
Email: euinfo@major-equipment.com

Web: www.major-equipment.com



Find us on FACEBOOK
MAJOR MACHINERY



View our channel
MAJOREQUIPMENT

Disclaimer

While every effort has been made in the production of this manual to ensure that the information contained herein is full and correct, Major assumes no responsibility for errors or omissions.

Major reserves the right to modify the machinery and the technical data contained within the manual without prior notice.

Further to this, Major assumes no liability for any damages which may result from the use of the information contained within this manual.

Contents

Introduction

Thank you	1
Using Your Operator's Manual	1
Safety Aspects	1
Intended use	1

Product Identification

Machine Serial Numbers	1
Register Your Product and Warranty Online	1
Product Specifications	2

Safety

Machine Safety Labels	2
Hazards associated with operating Grass Cutting Machinery	3
Operating Safely	4
Workstation	4
Regulations for use of the transmission	4
PTO Shaft Safety	5
Driving Safely on Public Roads	5

Operating the Machine

Key to Main Parts	6
Inspections before Use	7
Starting Regulations	8
Attaching machine to the Tractor	8
Transport Position	8
Operating the Machine/Mowing	9
Roller adjustment	10

Maintenance

PTO Shaft Maintenance	11
Blade Rotation	11
Maintenance position of the rear deck	12
Greasing Schedule	12
Rollers	13
Gearbox Oil	13
Troubleshooting	13

MJ75 Spare Parts

MJ75-360 Bogey Assembly	15
MJ75-360 Rear Deck Assembly (MJ75-360-RDGA)	20
MJ75-360 Right Wing Assembly (MJ75-360-WGGA)	22
MJ75-360 Left Wing Assembly (MJ75-360-WGLGA)	24
MJ75-360 Roller (CTR-360-WGROL)	26
Blades MJ75	27
S3035230012-2.30	28

EEC certificate of conformity for machines

(conforming to Directive 98/37/EEC)

Company: Major Equipment Ltd.
Address: Coolnaha,
Ballyhaunis,
Co. Mayo,
Ireland.
Tel. +353949630572
Fax +353949630788

declares in sole responsibility that the product:

MJ75 ROLLERMOWER (CONTOURA)

When properly installed, maintained and used only for it's intended purpose, complies with all the essential Health & Safety requirements of:

- **THE SUPPLY OF MACHINERY (SAFETY) REGULATIONS 2008.**
- **S.I. No. 299 of 2007**, Safety, Health and Welfare at Work (General Application) Regulations 2007 (Ireland).
- **Health & Safety at Work, etc. Act 1974 (c.37) (UK).**
- **EN ISO 14121-1: 2007** 'Safety of machinery. Principles for risk assessment'.
- **EN 745** - Agricultural Machinery - Rotary Mowers and Flail Mowers - Safety.
- **EN ISO 13857** - Safety of machinery: Safety distances to prevent hazard zones being reached by upper and lower limbs.

I certify on behalf of Major Equipment Int. Ltd., that this machine when properly installed and operated correctly, complies with all the essential Health & Safety requirements of all legislation referred to above.

Signature : 

Managing Director

Date 06/04/2017

Introduction

Thank you

We appreciate having you as a customer and wish you many years of safe and satisfied use of your machine.

Using Your Operator's Manual

This manual is an important part of your machine and should remain with the machine when you buy it. Reading your operator's manual will help you and others avoid personal injury or damage to the machine. Information given in this manual will provide the operator with the safest and most effective use of the machine.

Sections in your operator's manual are placed in a specific order to help you understand all the safety messages so you can operate this machine safely. You can also use this manual to answer any specific operating or servicing questions.

Safety Aspects

Your manual contains special messages to bring attention to potential safety concerns, machine damage as well as helpful operating and servicing information. Please read all the information carefully to avoid injury and machine damage.

Intended use

This machine is a grass cutting machine and designed for cutting grass. Moreover, it must only be used with a suitable tractor (see "Product Specifications" section of this booklet) and driven by an adequate drive-line of the tractor PTO. All other use is strictly prohibited.

Product Identification

Machine Serial Numbers

If you need to contact MAJOR or your MAJOR dealer for information on servicing or spare parts, always provide the product model and serial numbers. Model and Serial number can be found on the Serial Plate located on the machine.

We suggest that you record your machine details below:

Model No: _____

Serial No: _____

Date of Purchase: _____

Dealer Name: _____

Dealer Telephone: _____



Register Your Product and Warranty Online

To register your product through the Internet, simply go to the Support section on www.major-equipment.com. Completing the information, either online or with the product warranty card, will ensure the customer that their product receives all post sales service and important product information.

This machine is warranted for 12 months with. No warranty is given where the machine is being used as a hire machine. Warranty is against faulty workmanship or parts.

Warranty covers parts only. All parts must be returned to the manufacturer. No warranty can be considered unless parts are returned. All replacement parts will be supplied on a chargeable basis until warranty has been accepted.

Product Specifications

Model	Overall Width	Working Width	Transport Width	Power (HP)	PTO rpm	Cutting Height (mm)	Rotors/Blades	Weight (kg)	Blade tip speed (m/s)	Mowing Rates (Acres/hr at 7mph)
MJ75-360	3.67m (12')	3.60m (11' 9")	2.14m (7')	45-75	540	15-85	6/12+12	1395	86	5.3

Safety

Machine Safety Labels

The machine safety labels shown in this section are placed in important areas on your machine to draw attention to potential safety hazards.

On your machine safety labels, the words DANGER, WARNING, and CAUTION are used with this safety alert symbol. DANGER identifies the most serious hazards.

The operator's manual also explains any potential safety hazards whenever necessary in special safety messages that are identified with the word, CAUTION, and the safety-alert symbol



To avoid injury, read the manual



Check the tightness of the transmission



PTO entanglement hazard - keep clear of PTO drives.

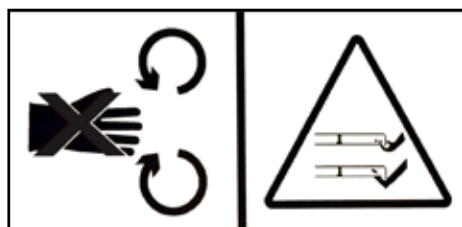

Rotating blade hazard



Grease points



Moving parts



Maximum speed

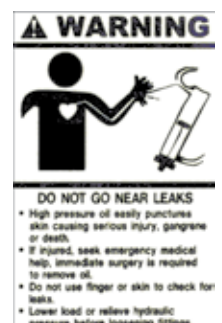

High oil pressure hazard

Hazards associated with operating Grass Cutting Machinery

Shear Hazard

Shear hazards are created when the edges of two objects move toward or next to each other closely enough to cut relatively soft material. This can include the parts of the machine under hydraulic control when operating from transport to mowing position. Note, the wing units are designed to float independently of the centre deck & are free to move within operating limits.

Crush Hazard

Bystanders can be injured when machine is lowered into mowing position. Winged machines have crush points around the hinge areas & between the wing & main body. Always use transport locking bars when not in use (winged models only).

Rotating Blade Hazard

All persons are at risk if they place their hands or feet under the machine when it is raised from the ground when the blades are in motion.

Pinch Hazard

Pinch points are created when two objects move together, with at least one of them moving in a circle. This hazard is common in power transmission devices such as Belt Drives, Gear Drives & Rollers. Ensure all guarding is present.

Wrap Hazard

Any exposed, rotating machine component is a potential wrap point. Injuries usually occur when loose clothing or long hair catch on and wrap around rotating parts such as PTO shafts or Drive shafts on the machine. Ensure all guarding is present.

Free-wheeling parts Hazard

The heavier a revolving part is, the longer it will continue to rotate after power is shut off. This characteristic is called 'free-wheeling.' Blades, and various other components, drive shafts etc., will continue to move after power is shut off - often for several minutes. Injuries occur when:

- Operators shut off equipment, and attempt to clean or adjust a machine before components have completely stopped moving.
- Shear bolt protection device in PTO shaft shears & the mowing parts are still spinning but the primary PTO shaft is stationary. Operator awareness is the key to safety around freewheeling parts. Never raise the machine while the blades are still rotating.

Thrown objects Hazard

Machines throw material as a natural part of doing their job. Foreign objects, such as stones, sticks and other debris, may be taken into this equipment and expelled at tremendous speed. These objects are contained by the sides of the machine and by the rear/front rollers / guards / chain guards / rubber skirts depending on model of your machine.

Ensure bystanders are clear from the machine & cannot be hit with debris expelled from the machine. Bystanders or animals in the path of thrown objects could be seriously injured. Never operate machine with decks raised from the ground as this makes the front/rear protection redundant.

Hydraulic Hazard (if applicable)

Hydraulic systems store considerable energy. Careless servicing, adjustment, or replacement of parts can result in serious injury. High pressure blasts of hydraulic oil can injure eyes or other body parts. The following precautions are crucial:

- Make certain the hydraulic pump is turned off.
- Lower attached equipment to the ground.
- Confirm that load pressure is off the system.

A pinhole leak in an hydraulic hose is a serious hazard. A leak may not be visible, and the only sign may be a few drops of fluid. Never inspect hydraulic hoses with your hands, because a fine jet of hydraulic fluid can pierce the skin.

Slips, Trips and Falls Hazard

Slips and falls often result from:

1. Slippery footing on the ground
2. Cluttered steps and work platforms.

The potential for slips and falls can be greatly reduced by using good judgement and practicing good housekeeping on and around equipment.

Noise Hazard

Please note that the machine is normally used outdoors and that the position of the operator is seated in the driving seat of the tractor. It is advisable to consult the prescriptions listed in tractor operator and maintenance manuals.

The acoustic pressure at a distance of 2.6m from the centre of the machine and at a height of 2.0m, with the implement operating in a no load condition can reach 90 dBA. In a loaded condition & a PTO rate of 540 rpm the value can reach 97dBA. Higher rate of PTO input will result in in higher noise levels. Always wear hearing protection.

Operating Safely

This MAJOR machine is designed to operate at a PTO rate which is stated in the Product Specifications part of this booklet. Ensure tractor PTO output is set at a correct RPM rate. This MAJOR machine must only be used for purposes outlined in the Intended Use section of this booklet. All other use is strictly prohibited.



Users should become thoroughly familiar with the contents of this manual before using, servicing and mounting the implement to the tractor and all other pertinent operations. Never wear jewellery, loose clothing such as ties, scarves, belts, unbuttoned jackets or dungarees with open zips which could become caught up in moving parts.



Always wear approved garments complying with accident prevention provisions such as non-slip shoes, ear muffs, goggles and gauntlets. Wear a jacket with reflecting stickers if the implement is used near public highways.



Consult your retailer, the Labour Health Service or your nearest equivalent authority for the information about the current safety provisions and specific regulations with in order to ensure personal safety.



ALWAYS DISENGAGE PTO, SWITCH OFF THE TRACTOR ENGINE AND ENGAGE THE PARKING BRAKE BEFORE MAKING ADJUSTMENT TO THE MACHINE.



NEVER PLACE LIMBS UNDER THE MACHINE WHILE ROTOR(S) ARE TURNING. ROTOR(S) CAN REMAIN TURNING FOR UP TO 1 MINUTE AFTER DISENGAGING PTO.

Workstation

The operator must remain seated while working the machine. If the machine is a winged unit and the wings need to be raised/lowered the operator must not leave the tractor. Always ensure the PTO has been turned off and the parking brake applied before leaving the tractor cab or carrying out maintenance.



NEVER OPERATE THE HYDRAULICS WITH THE TRACTOR SWITCHED OFF

Regulations for use of the transmission

The transmission to the gearboxes is protected throughout the machine by both PTO shafts and bolt down covers. All guarding should be kept efficient and in good condition. If the condition is poor, the guarding should be renewed before the implement is used.



UNLESS IT IS CORRECTLY PROTECTED THE TRANSMISSION COULD CAUSE DEATH SINCE IT CAN CATCH ON PARTS OF THE BODY OR CLOTHING

Ensure retaining chains are correctly anchored on all PTO shafts, preventing them from turning. Ensure drive line can turn easily within the shield. Keep spline grooves clean and greased so that PTO shaft can connect easily. Besides being described in this booklet, the method by which the PTO shaft is connected to the tractor must be checked out with the instructions in the tractor manufacturer's manual.

PTO Shaft Safety

Maximum PTO input is specified in the Product Specifications section of this booklet. Contact your nearest dealer or a specialised retail outlet if the PTO must be replaced with a longer one, since this must belong to the same power category and possess the same characteristics. An unsuitable PTO could easily break.

The tractor PTO shaft length may be altered to suit the individual tractor model. When the machine is in operation, the PTO shaft should have a minimum 1/3 engagement as shown in the diagrams. After the machine has been hitched to the tractor, it should be checked in various positions that the drive line is the correct length. If the PTO is too short and tends to slip out of place, it must be replaced with a longer one.

If the PTO shaft is too long, it should be shortened in the following way:

- Set the machine at a minimum distance from the tractor, then brake the tractor and switch off the engine.
- Separate the two halves of the PTO. Insert the female part into the tractor PTO and the male part into the machine PTO, checking that the position is correct by means of the fixing pins.
- Line up the two halves of the PTO together, keeping them parallel.
- Using a felt tip pen, match mark the place where the two halves must be shortened as shown.
- First cut shield "1" and use part "2" as a reference to cut the splined shaft.
- Proceed in the same way for the second half.
- Trim and chamfer the two cut ends of the PTO and clean off all swarf and shavings.
- Grease the two profiles and join the two halves of the PTO together.
- Mount the PTO shaft and check that its length is correct as before.



Do not use the shaft cone as a step

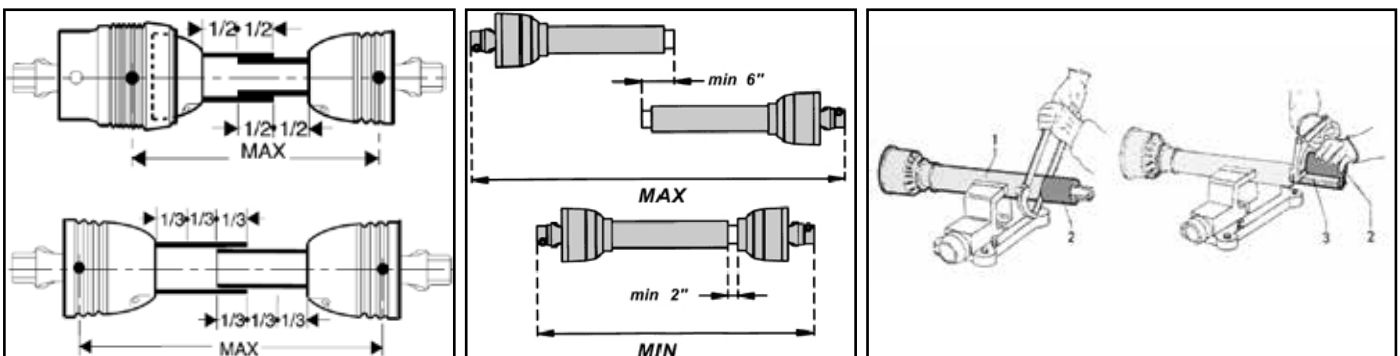

Driving Safely on Public Roads

Check the local Highway Code regulations before driving the tractor on public highways with an implement attached. Check the reflectors, hazard flashers and/or projecting load indicators are installed when required and efficient. These indicators must be installed correctly and easily seen by the drivers of other vehicles.

Bystanders must not be allowed to lean against or climb onto the machine during transport or while working. Do not allow bystanders to ride on the machine.



**MAXIMUM TRANSPORT SPEED
MUST NOT EXCEED 30 km/hr (18 MPH)**

General safety instructions

Precautions to be taken while working with the machine:

1. Do not operate the machine when you are tired;
2. Before starting mowing, make sure that the area is clear of people or animals.
3. Before starting adjusting the machine, it is mandatory to disconnect the PTO, to turn off the engine of the tractor, apply handbrake and wait for the turning parts to become still and placed on the ground.
4. It is mandatory to read all the safety requirements and the operator's manual of the machine.
5. If you are not sure how to use the machine, please contact the manufacturer or the dealer.

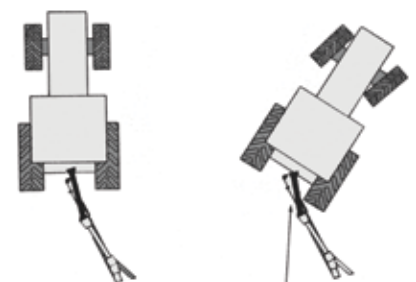

Operating the Machine

This machine is designed to be connected to a tractor by using a standard tow hitch connection.

Key to Main Parts

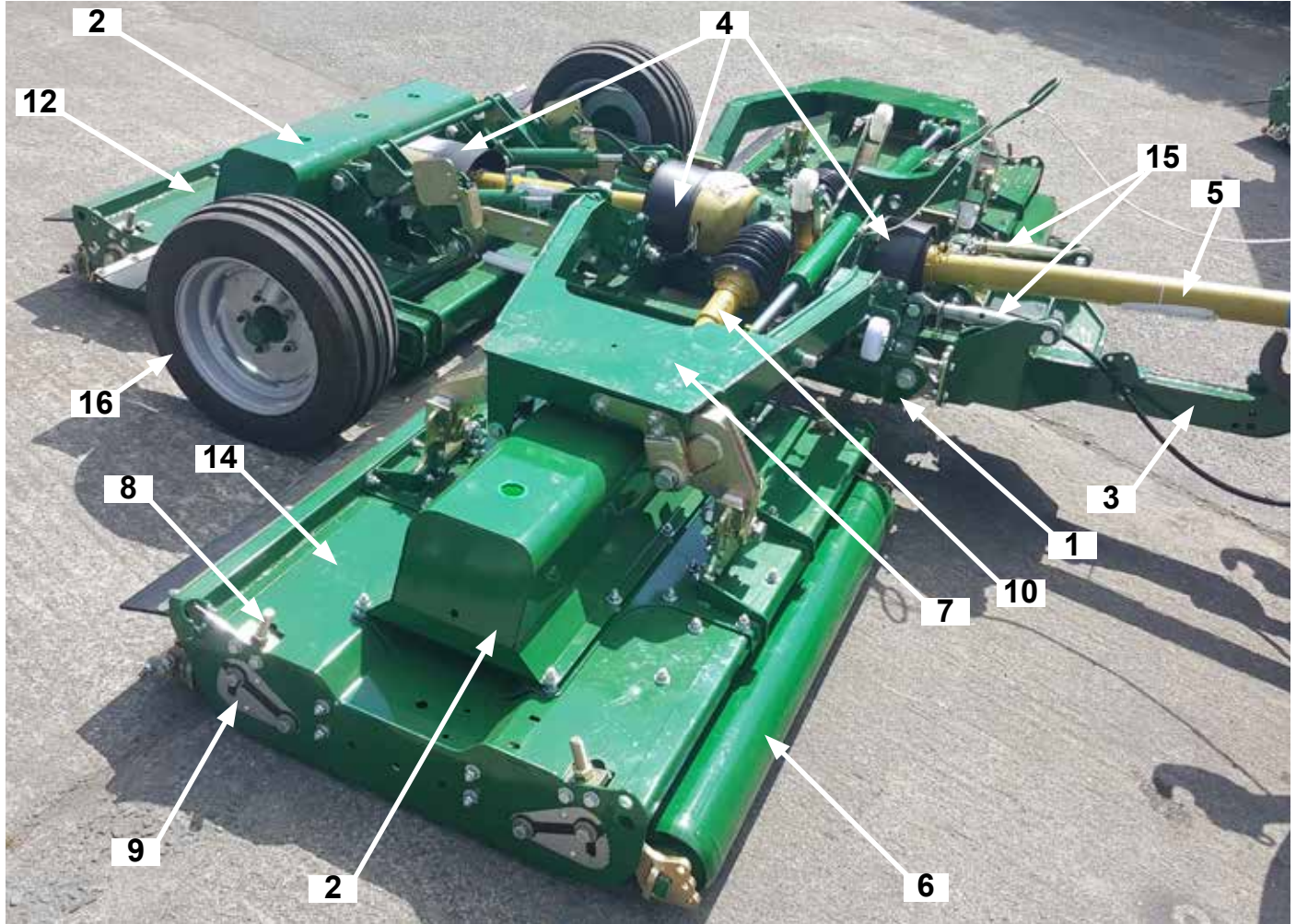

- | | |
|----|----------------------------|
| 1 | Body |
| 2 | Drivetrain cover |
| 3 | Drawbar |
| 4 | Gearbox PTO cover |
| 5 | PTO shaft |
| 6 | Roller |
| 7 | Wing arm |
| 8 | Roller height adjuster rod |
| 9 | Roller height indicator |
| 10 | Wing PTO shaft |
| 11 | Blades |
| 12 | Rear deck |
| 13 | Scraper bar |
| 14 | Wing |
| 15 | Drawbar height adjuster |
| 16 | Wheel |
| 17 | Rubber deflector |

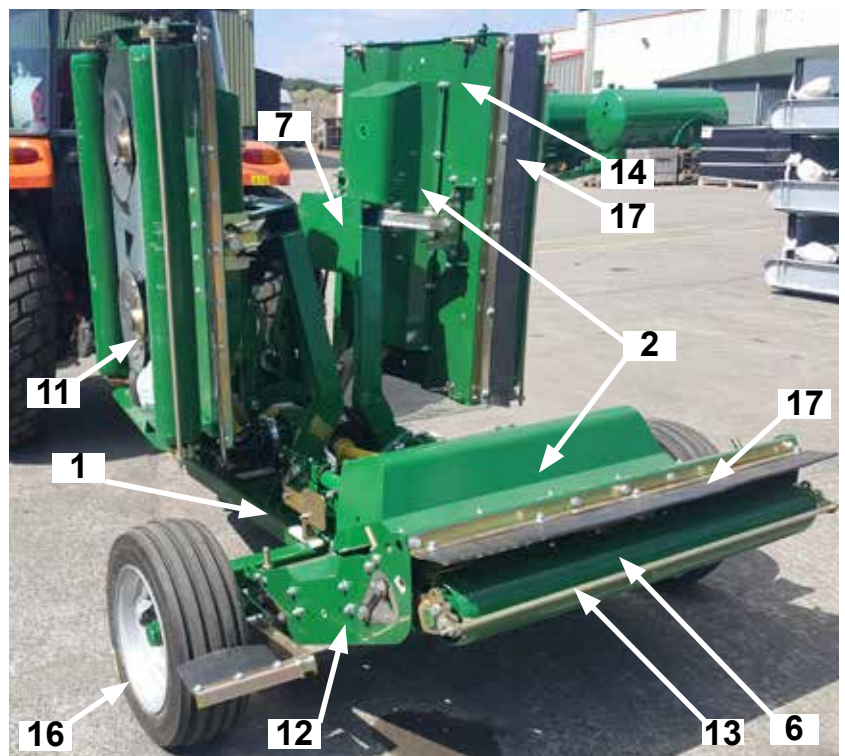

Inspections before Use



Always disengage PTO, Switch off tractor engine and engage the parking brake before making adjustments to the machine.

1. With the whole machine as level as possible, check the oil level in the gearboxes and top up as required with recommended gear oil through the oil filler plug indicated. The correct level is at the oil level plug indicated.

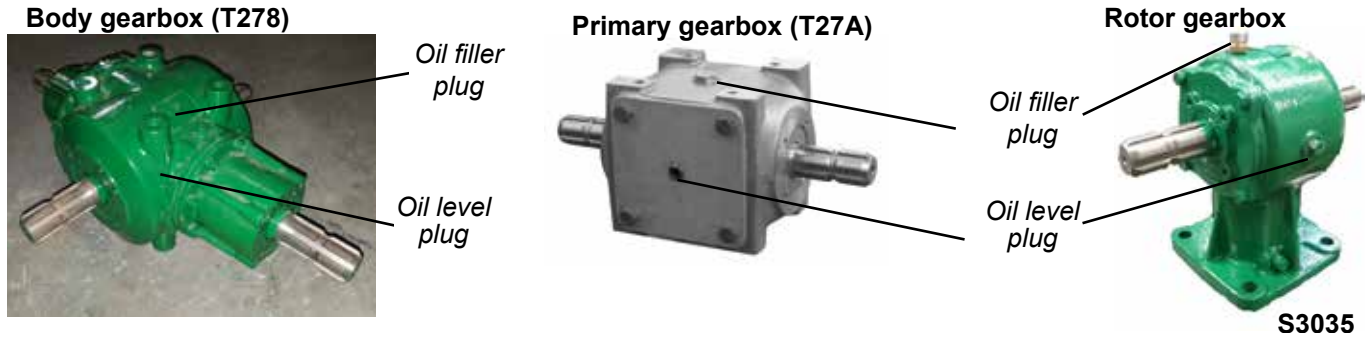

2. Grease the PTO shaft universal joints, drive shaft bearing and carrying arm pivots.
3. Check the blades for wear and damage and replace worn blades with new ones if required.
4. If the blade assembly is removed check the blade mounting ensure the gearbox shaft nut is tight and retained in place by split pin.

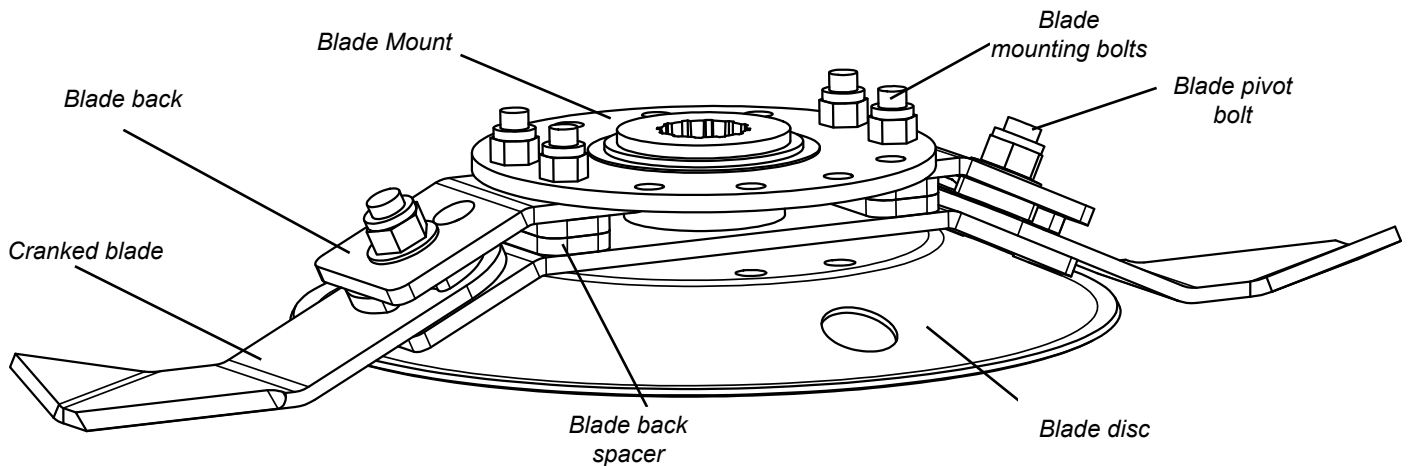

5. Check tightness of all nuts, bolts and retaining screws after the first and second hours of work.
6. Ensure safety guards and flaps are in place at all times where fitted. If these become worn or missing, replace them immediately with new ones.
7. Due to the corrosive nature of grass when cut, wash down the machine when finished mowing, especially when the machine is being stored for a long period of time.

Starting Regulations



Always check that any imminently dangerous conditions have been eliminated before using the machine. Ensure all guarding is present & the operator is fully aware of the operations of the machine.



Always ensure the pins lock the PTO shaft yoke ends onto the spline shafts on both the tractor and the implement. An unlocked shaft could slip out of position, causing notable mechanical damage and serious injury to both operator and bystanders.

Attaching machine to the Tractor



Always operate on level ground when attaching/detaching the machine. This will prevent dangerous movement. Never allow anyone to stand between the tractor and the machine. **DO NOT CUT PTO SHAFT. ADJUST DRAWBAR**

1. Reverse the tractor, connect the hitch & secure in position with correct size drawbar pin
2. Ensure that the circlip is on top (see diagram below).
3. Ensure the tractor brake is applied
4. Adjust the level of the drawbar until the main body is level (see diagram below).
5. Connect the hydraulic connections to the tractor.
6. Fit the PTO shaft & secure the PTO cover chains.
7. Adjust drawbar instead of cutting PTO shaft.
8. Lift the parking stand and lower the PTO stand (see diagram below).

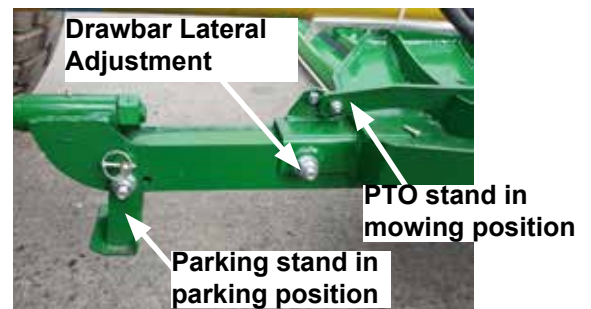
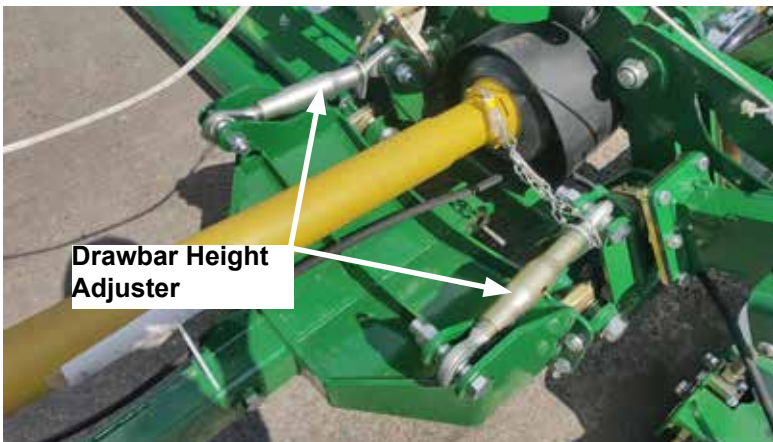
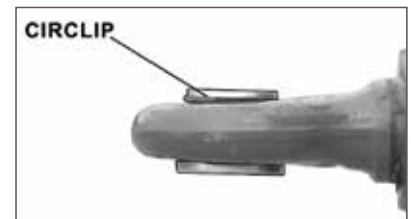

Transport Position



Before raising the machine wait until the transmission and the blades are completely still. During the transport of the machine it is recommended that the PTO shaft is disconnected.

1. Check machine is hitched to the tractor as described. Ensure the tractor parking brake is applied
2. Ensure moving parts become still then transform the machine into transport position by hydraulic control
3. To lift up the wings, pull the cord until the Kerb lift plate rises and operate the hydraulics.
4. Lift the rear deck up by operating hydraulics.



Do not lift the wings/rear deck while PTO is still in motion. This may damage the PTO shaft and other components.

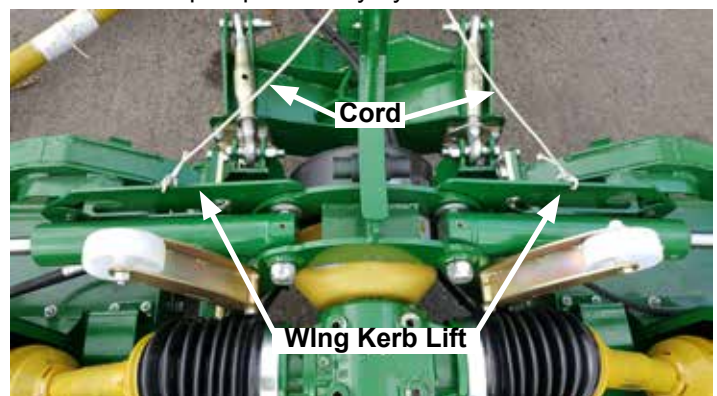

IMPORTANT: The transport locking bar and pin should always be slotted into place while transporting the machine.

Transport Bar Position

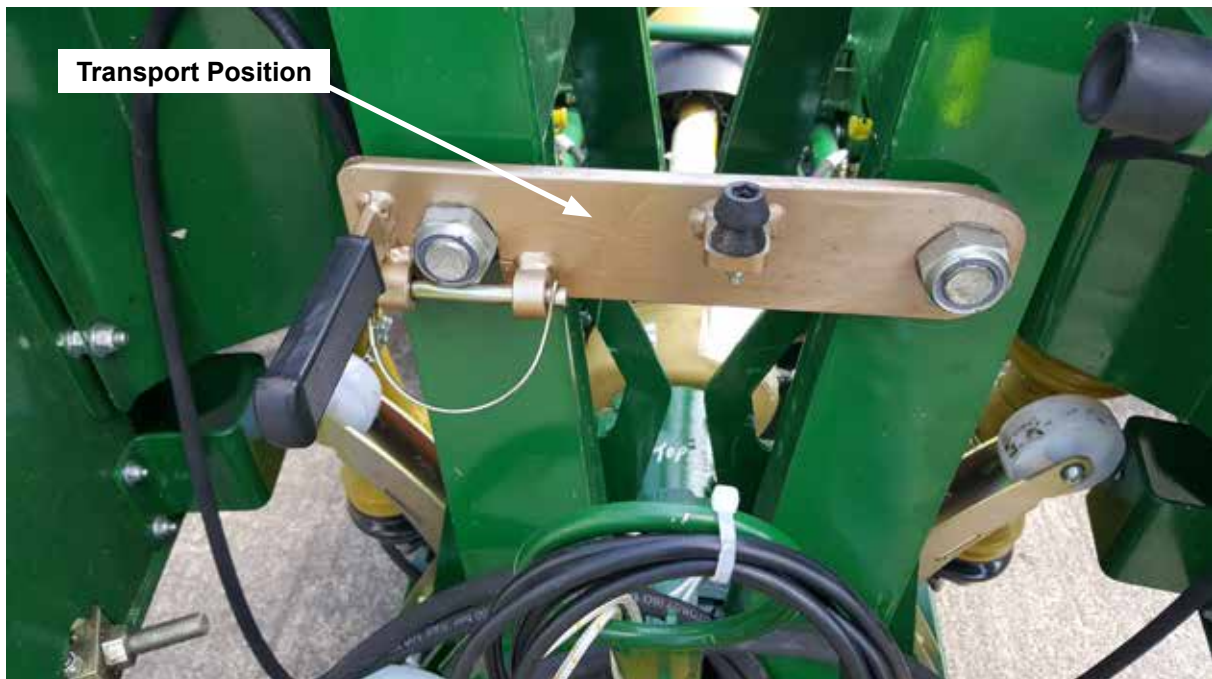

Operating the Machine/Mowing



Never place limbs under the machine while rotors are turning. Rotors can remain turning for up to 1 minute after disengaging PTO.



While operating this machine the PTO input rate should not exceed the RPM stated in the Product Specifications section of this booklet. Always operate on level ground when connecting/disconnecting the implement. This will prevent dangerous movement.



Never allow anyone to stand between the tractor and the machine. Ensure the machine is attached correctly to the tractor as previously described. Always start up the tractor PTO at a low RPM. Build up to operating speed, select a suitable forward gear & proceed to cut grass.

1. Hitch the machine as outlined in the previous section. Ensure bystanders are clear from the machine & cannot be hit with debris expelled from the machine.
2. Lift up the Parking stand.
3. Ensure the PTO stand is flipped down.
4. Check PTO shaft is fully engaged on tractor PTO splines.
5. After clearing the vicinity of bystanders, relocate the Transport Bar.
6. Start up the tractor PTO at a low RPM.
7. Build up to operating speed, select a suitable forward gear & proceed to cut grass.

Roller adjustment

In order to achieve desired cutting height, castor wheels and roller should be adjusted.

Roller

To adjust the height of the roller follow this procedure at both sides of the roller:

1. Loosen Bolts **B** and **C** (Note: You do not have to remove these bolts, half of the turn will suffice to allow movement);
2. Turn Nut **D** clockwise to increase the cut height or anti-clockwise to decrease the cut height;
3. Match the height of the roller on both sides of the machine by checking the position of Arrow **A**;
4. When adjustment is complete, re-tighten Bolts **B** and **C**.

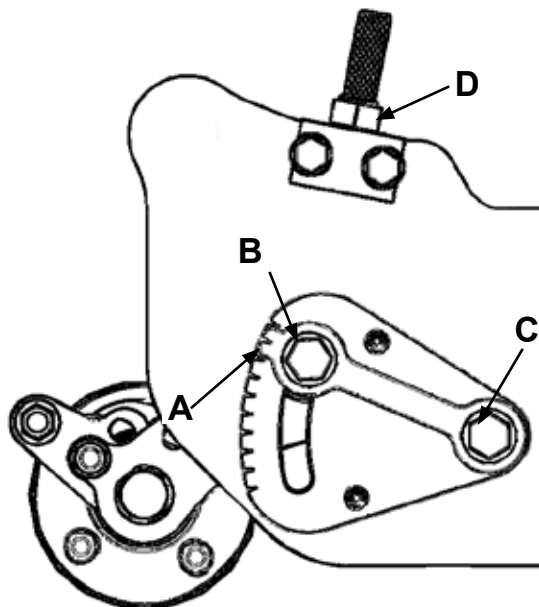

Scraper bar

Please follow these steps if your machine is equipped with a scraper bar. In order for a scraper bar to function properly, it should be kept tensioned. To tension the scraper bar (1) tighten up nuts (2) at both ends of the roller (3). Locate the scraper bar bracket (4) in a desired position by looseing/tightening bracket nut (5).

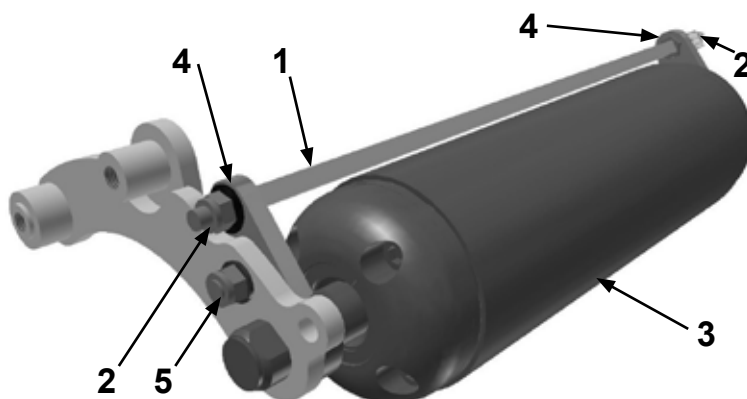

Maintenance

The machine must always be disconnected from the tractor before any cleaning, lubricating and servicing operations can be carried out. Maintenance must be carried out by qualified personnel.

If emergency operations are required whilst the machine is connected to the tractor, switch off the engine, engage the parking brake and disengage the PTO.

Good, regular maintenance and correct use are advised if the machine is to remain safe and long lasting.

PTO Shaft Maintenance

Guard Removal and Yoke End Greasing

1. Prise back locking tabs
2. Pull back PTO Guard
3. Grease points as shown
4. Push Guard into position
5. Click into place
6. Tie check chain

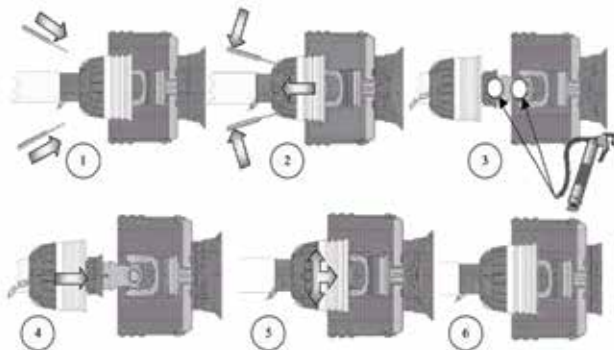

PTO Guard Greasing Intervals

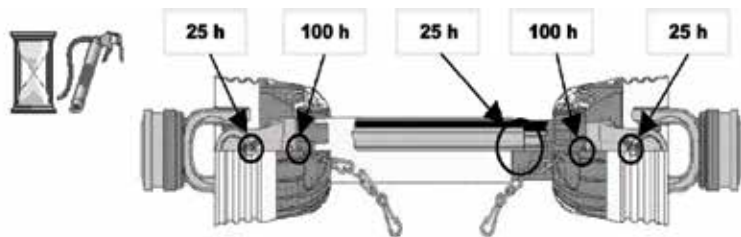

Maintenance of other components

- All nuts and bolts in the transmission including Rubber couplings, Star Drives, PTO Shafts and Gearboxes should be checked for tightness after mowing at the following intervals:
 - 1st 40 hours
 - 1st 100 hours
 - 1st 250 hours
 - And every 250 hours thereafter.
- Check blades on a regular basis for wear. Replace any damaged or worn parts immediately.

Blade Rotation



Ensure blade rotation and timing (90 degrees) is correct after servicing transmission.

MJ75-360

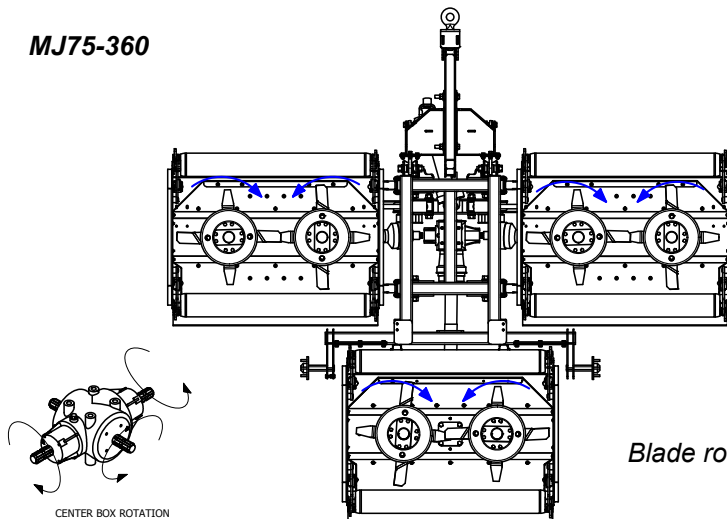

Blade rotation viewed from underside

CENTER BOX ROTATION
VIEWED FROM TOP, LOOKING AT MACHINE.

Maintenance position of the rear deck



Always disengage PTO, Switch off tractor engine and engage the parking brake before making adjustments to the machine.



PTO shaft between the body and rear deck must be disconnected before lifting the rear deck. Failure to do so may damage the shaft and other components.

Rear deck of the machine can be flipped up to allow access for maintenance. In order to do this raise the ram stops and push kerb lift brackets down, then operate the hydraulics until the deck is up as shown.

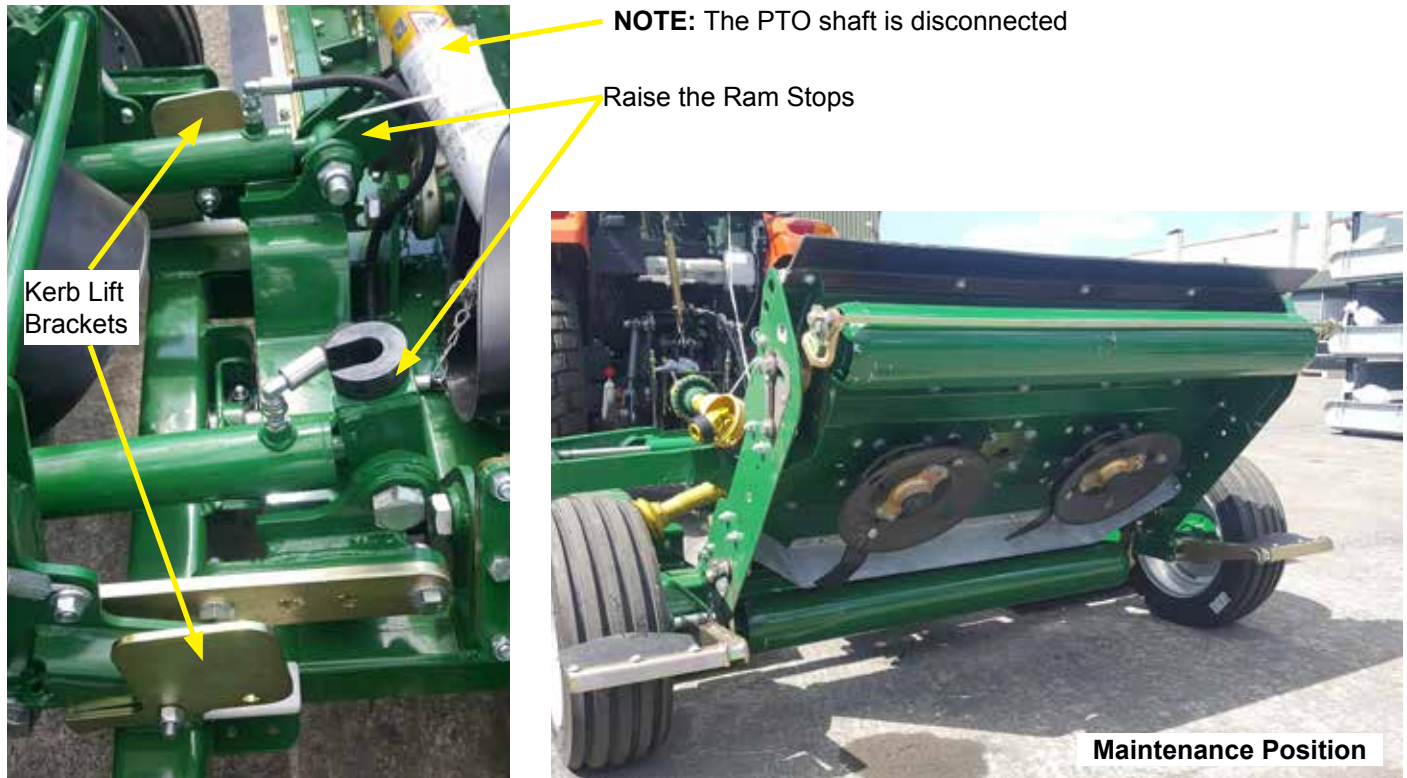

Greasing Schedule

Lubricate moveable mechanical joints when required.

Greasing points	First 8 hours	16 hours thereafter	80 hours thereafter
PTO Shafts (4 shafts)	●	●	
Roller height adjuster block (4 per deck/wing)	●		●
Roller height adjuster rod (4 per deck/wing)	●		●
Roller stub axle (4 per deck/wing)	●		●
Drawbar hitch (1)	●		●
Drawbar pivot (2)	●		●
Rear deck pivot (4)	●		●
Wing arm pivot (2 per arm)	●		●
Wing hydraulic ram (1 per ram)	●		●
Wing pivot (2 per wing)	●		●
Wing tilt pivot (2 per wing)	●		●

Rollers

Check the condition of the roller stub axles at the end of every season. Roller must be able to rotate freely and without excessive play. If necessary, remove the roller end and adjust the tightness of the bearings.

Gearbox Oil

Replace oil in gearboxes after first 100 hours and every 400 hours thereafter.
Use oil which conforms to 80W/90 standards.

Troubleshooting

Fault	Cause	Remedy
Leaves a streak of uncut or partially cut grass	Blades dull or bent	Replace blades
	Carrier RPM too low	Use correct PTO speed
	Field conditions are so wet that the wheels are pushing grass into mud	Too wet to mow. Stop operation and wait until it is drier
	Ground speed too fast	Reduce ground speed by shifting to a lower gear
	Grass is down from previous weather conditions	Mow in only one direction
	Possible build-up materials under machine	Clean the machine
	Blades mounted incorrectly (cutting edge against direction rotation)	Change blades so that cutting edge is facing correct rotation
Material discharges from machine unevenly; bunches of material along with swath	Material too high and too much material	Reduce ground speed but maintain recommended rpm at tractor PTO or make two passes over material. Raise machine for the first pass and lower to desired height for the second and cut a 90 degree angle to first pass
	Grass wet	Allow grass to dry before mowing. Slow ground speed of tractor but keep engine running at full PTO rpm. Cutting lower will help
Gearbox overheating	Low on lubricant	Fill to proper level
	Improper type lubricant	Replace with proper lubricant
	Excessive grass/debris build-up around gearbox. PTO running too fast.	Remove grass, etc from machine. Lower the RPM rate
Blade is scalping ground	Machine too low	Raise machine - reset wheels
	Field is ridged	Cut field at a different angle
	Field is too wet	Stop and wait until it is dried
Blades wear too fast	Cutting in sandy conditions	Increase cutting height
	Cutting in rocky conditions	Increase cutting height
	Blades hitting the ground	Increase cutting height
Machine seems to require excessive power	Advancing into grass too rapidly	Reduce forward travel speed
	Hitting ground	Raise machine and reset wheels
	Worn or dull blades	Sharpen or replace blades
Excessive vibration	Check gearbox bolts	Tighten if loose
	Check for loose nuts on blades	Tighten if loose
	Blade broken	Replace blades, in set
	New blade or bolts matched with worn blade or bolts	Replace blades or bolts in sets
	Drivelines not phased correctly. Implement and tractor yokes must be in line	Phase the driveline. Replace if necessary

Noisy machine	Low oil in gearbox	Check level and add oil
	Loose Parts	Check all bolts are fully tightened
	Wrong PTO rpm rate	Check PTO rate & adjust as necessary
	Rotors bent/broken	Replace bent or missing blades
	Bent PTO shaft	Check PTO shaft aligned correctly
	Bent gearbox shaft	Check output shaft on gearboxes are not bent
		Check driveline between gearboxes is aligned
Gearbox leaking	Damaged oil seal	Replace seal
	Bent shaft	Replace oil seal and shaft
	Shaft rough in oil seal area	Replace or repair shaft
	Oil seal installed incorrectly	Replace seal
	Oil seal not sealing in the housing	Replace seal or use a sealant on outside diameter of seal
	Oil level too high	Drain oil to proper level
	Hole in gearbox	Replace the gearbox
	Gasket damaged	Replace gasket
	Bolts loose	Tighten bolts

MJ75 Spare Parts

MJ75-360 Bogey Assembly

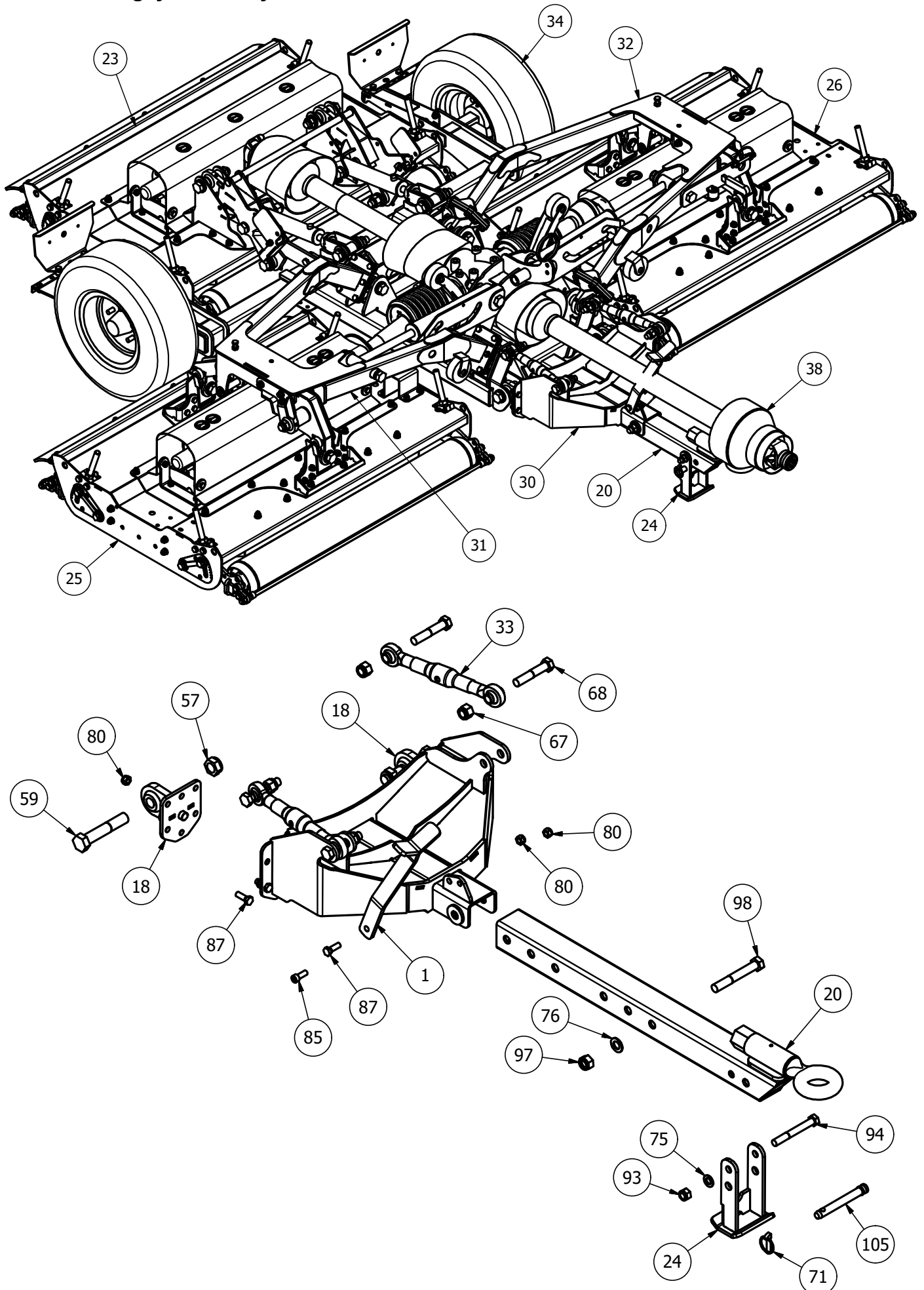

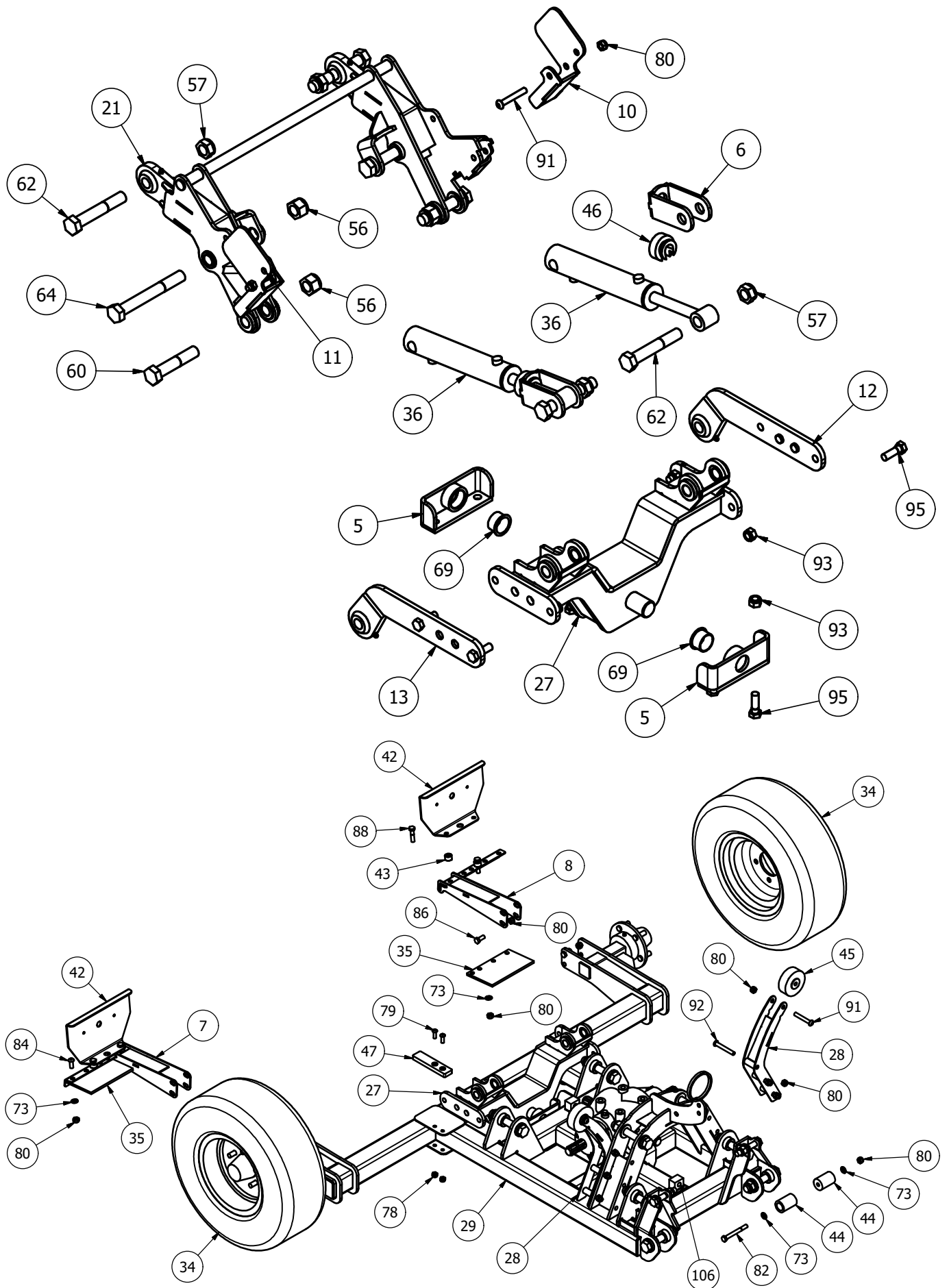

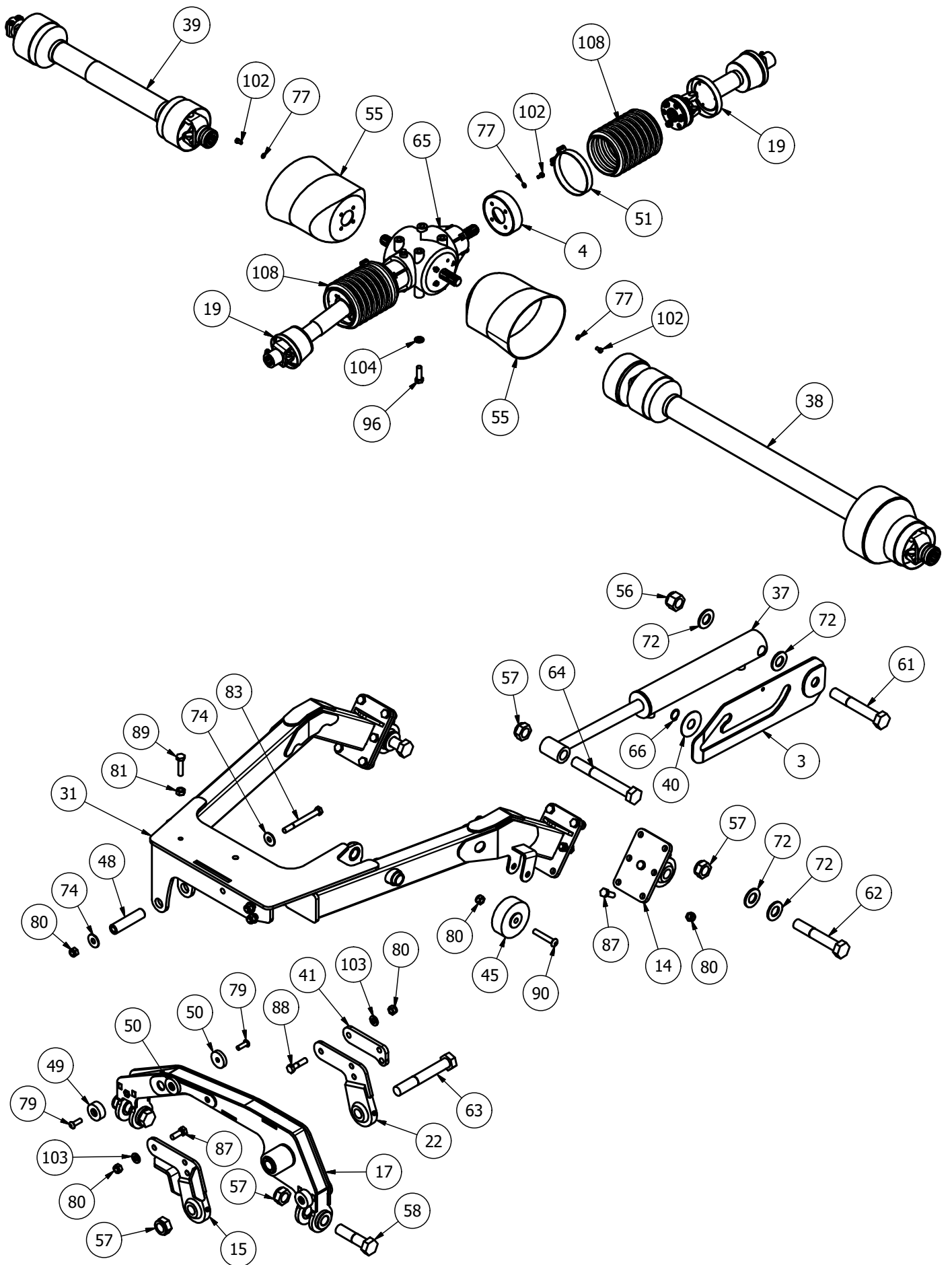

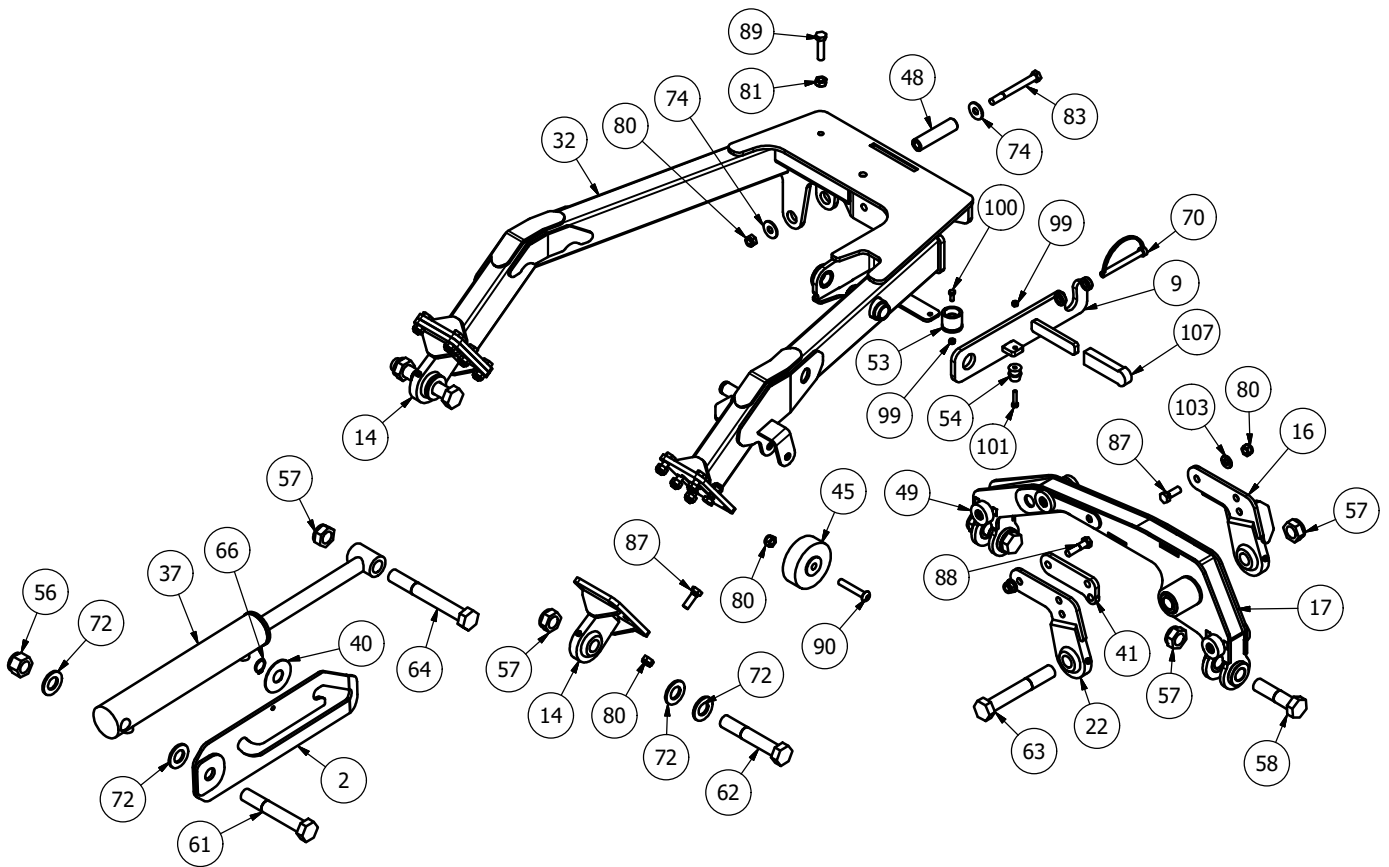

Item	Part No	Description	Qty
1	12DB-030	PTO STAND	1
2	CTR-CBL05H	CURB LIFT	1
3	CTR-CBLF05	CURB LIFT	1
4	CTR-GRD01	PTO GUARD	2
5	CTR-RDPV40	REAR PIVOT MOUNT	2
6	CTR-RDPV50	RAM CURB STOP	2
7	MJ365-C-WHEEL-FLAP	WHEEL FLAP BRKT	1
8	MJ365-C-WHEEL-FLAP-H	WHEEL FLAP BRKT	1
9	MJ365-LA04	LATCH (WINGS)	1
10	MJ365-RA-KERB-LOCK	KERB LOCKER REAR	1
11	MJ365-RA-KERB-LOCK_MIR	KERB LOCKER REAR	1
12	MJ365-RRL-EYE-2	CAT 2 EYE	1
13	MJ365-RRL-EYE-2H	CAT 2 EYE	1
14	MJ365-WA-EYE	CAT 2 EYE	4
15	MJ365-WRL-EYE-OUTER	CAT 2 EYE	1
16	MJ365-WRL-EYE-OUTER-H	CAT 2 EYE	1
17	MJ365-WRL-WELDMENT-1	WING ROCKER ARM	2
18	MJ70-TDBP01	DRAWBAR PIVOT	2
19	MJ75-360-DRV01	WING DRIVE ASSY	2
20	MJ75-360-HT01	HITCH	1
21	MJ75-360-RA01	REAR PIVOT ARM	1
22	MJ75-360-RAE01	CAT 2 EYE	2

23	MJ75-360-RDGA	REAR DECK ASSEMBLY	1
24	MJ75-360-STD01	TRAILED STAND	1
25	MJ75-360-WGGA	360 WING ASSY (RH)	1
26	MJ75-360-WGLGA	360 WING ASSY (LH)	1
27	CTR-RDPV10	REAR DECK PIVOT	1
28	MJ365-C-NYLONROLLERBRKT	BUMP ROLLER BRKT	2
29	MJ365-C-WLDMT	CHASSIS WELDMENT	1
30	MJ75-360-DB01	DRAWBAR	1
31	MJ75-360-WA01	WING ARM (RH)	1
32	MJ75-360-WA30	WING ARM (LH)	1
33	15502	CAT 0 TOP LINK	2
34	200-60-145	BKT DIA 610x210 5 STUD	2
35	MJ365-C-0052	RUBBER FLAP	2
36	MJ365-RDR	CONTOURA REAR DECK RAM	2
37	MJ365-WR	CONTOURA WING RAM	2
38	WS603672	WIDE ANGLE 2380 FIXED SLIP	1
39	WS694098	2200 SHEAR BOLT O/R	1
40	CTR-CBLF04	KERB LIFT WASHER	2
41	MJ75-360-WA20	EYE SPACER	2
42	TDC-LIT7	LIGHT BRKT	2
43	12T-BBS	BLADE BACK SPACER	4
44	CTR-CHA50	WING ARM STOP	2
45	CTR-CHA51	WING STOP	4

46	CTR-RDPV55	RAM CURB STOP	2
47	MJ365-L018	Nylon Buffer	2
48	MJ365-WA-0027	TILT BUSH	2
49	MJ365-WRL-0012	Nylon Buffer	8
50	MJ365-WRL-0015	NYLON BUFFER	4
51	11402	HOSE CLIP 149-161	2
52	12837	PULL CORD	1
53	18983	DOOR HOLDER (FEMALE)	1
54	18984	DOOR HOLDER (MALE)	1
55	190.000.545	PTO GUARD (EXTENDED OVAL)	2
56	1F	1" FINE NYLOC NUT	6
57	1UNF	1" FINE NYLOC (1/2 NUT)	18
58	1x4FBZP	1"x4" FINE BOLT	4
59	1x512FBZP	1"x5 1/2" FINE BOLT	2
60	1x5FBZP	1"x5" FINE BOLT	2
61	1x612FBZP	1"x6 1/2" FINE BOLT	2
62	1x6FBZP	1"x6" FINE BOLT	8
63	1x7FBZP	1"x7" FINE BOLT	2
64	1x8FBZP	1"x8" FINE BOLT	4
65	278221	T278 RATIO 1.92	1
66	2879	25mm EXTERNAL CIRCLIP	2
67	3/4F	3/4" FINE NYLOC NUT	4
68	34x4FBZP	3/4"x4" FINE BOLT	4
69	4026DU	40x44x26 FLANGE BUSH	2
70	AG272	SHAFT LOCK PIN DIA 11	1
71	AN099/10	LINCH PIN DIA 9.5	1
72	FW1	DIA 1" FLAT WASHER	12
73	FWM12	M12 FLAT WASHER	10
74	FWM12L	M12 FLAT WASHER (LARGE)	4
75	FWM16	M16 FLAT WASHER	1
76	FWM20	M20 FLAT WASHER	2
77	FWM8	M8 FLAT WASHER	16
78	M10	M10 NYLOC NUT	4

79	M10x30SKBH	M10x30 SOCKET BUTTON HEAD 10.9	16
80	M12	M12 NYLOC NUT	81
81	M12HEX	M12 PLAIN NUT	2
82	M12x110BZP	M12x110 BOLT	1
83	M12x120BZP	M12x120 BOLT	2
84	M12x30SKBH	M12x30 SOCKET BUTTON HEAD 10.9	4
85	M12x30SKS	M12x30 SOCKET HEAD SCREW	1
86	M12x30SZP	M12x30 SET BOLT	8
87	M12x35BZP	M12x35 BOLT	43
88	M12x50BZP	M12x50 BOLT	10
89	M12x50SZP	M12x50 SET BOLT	2
90	M12x70SKBH	M12x70 SOCKET BUTTON HEAD 10.9	2
91	M12x80SKBH	M12x80 SOCKET BUTTON HEAD 10.9	4
92	M12x90SKBH	M12x90 SOCKET BUTTON HEAD 10.9	6
93	M16	M16 NYLOC NUT	9
94	M16x130BZP	M16x130 BOLT	1
95	M16x50BZP	M16x50 BOLT	8
96	M16x50SZP	M16x50 SET BOLT	4
97	M20	M20 NYLOC NUT	2
98	M20x140BZP	M20x140 BOLT	2
99	M6	M6 NYLOC NUT	2
100	M6x16SZP	M6x16 SET BOLT	1
101	M6x30SZP	M6x30 SET BOLT	1
102	M8x16SZP	M8x16 SET BOLT	16
103	NL12SP	M12 SP NORDLOCK	12
104	NL16SP	M16 SP NORDLOCK	4
105	S77	CAT 1 PIN DIA 19x127mm	1
106	SP215-SIN	WELD CLAMP 15 ODx1/4" ID	2
107	VA1011251	HANDLE 25x10	1
108	WS124759-1	FLEXABLE WS PTO GUARD	2

MJ75-360 Rear Deck Assembly (MJ75-360-RDGA)

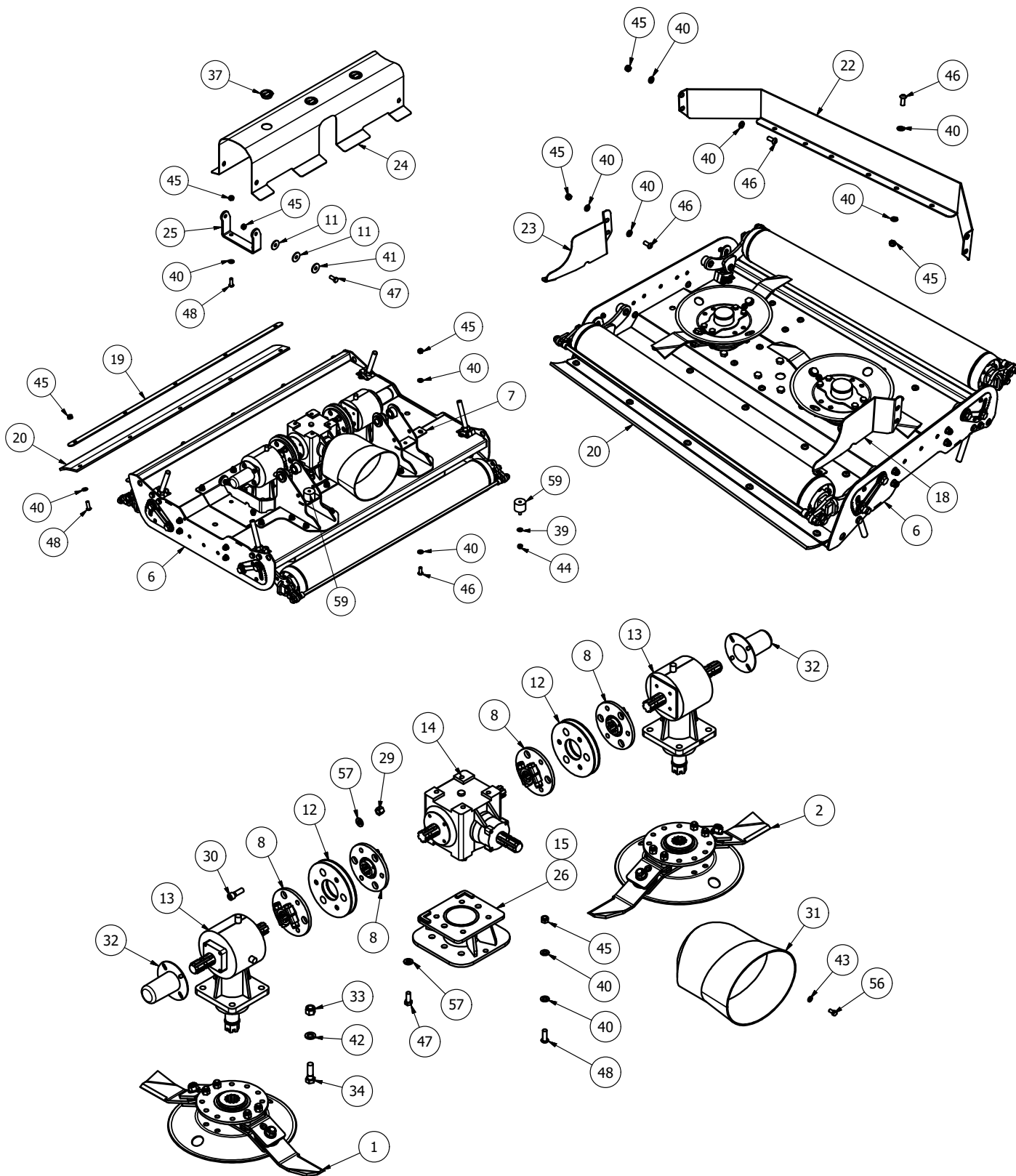

Item	Part No	Description	Qty
1	680-DCBLDLK-L	680mm LOCK BLADE (Anti-CLK)	1
2	680-DCBLDLK-R	680mm LOCK BLADE (CLK)	1
3	8400RM-HG65	M20 THREADED ADJUSTER	4
4	CTR-360-WGROL	360 WING ROLLER	2
5	MJ75-360-WSCRPR-01	360 CONTOURA SCRAPER	2
6	MJ75-360-RD01	REAR DECK	1

7	MJ75-360-RD30	REAR DECK LINKAGE	1
8	CM25-DRV	6 SPLINE STAR DRIVE	4
9	CTR-RPV10	ROLLER PIVOT	2
10	CTR-RPV20	ROLLER PIVOT	2
11	MJ40-270-RW01	RUBBER WASHER	8
12	MJRC-23	113 PCD COUPLING 4mm PLT	2
13	S3035230012-S	6 SPLINE 'T' BOX RATIO 2.3	2

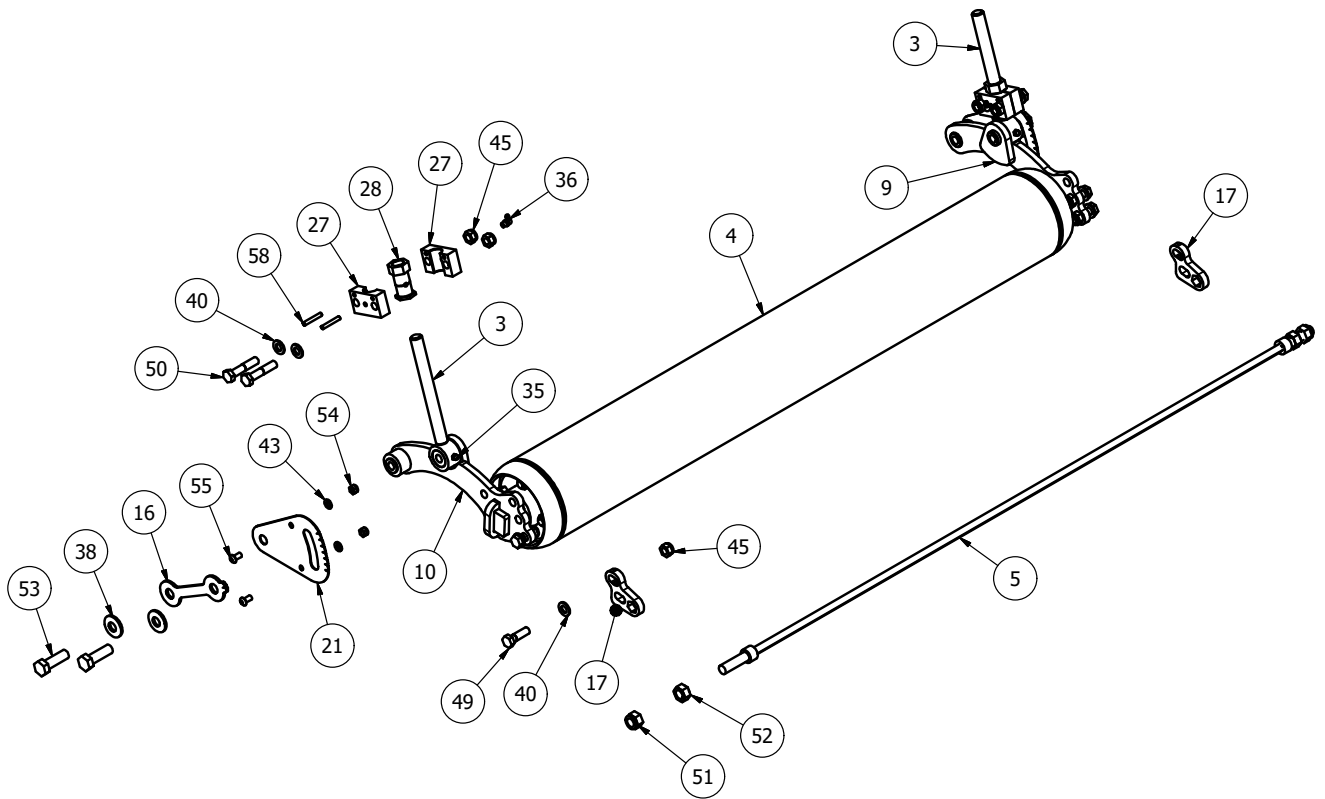

14	T27A267245	6 SPLINE 'T' BOX RATIO 1:1.92	1
15	2000CM-GBM09	GBOX SUPPORT	2
16	8400RM-HG03	HEIGHT INDICATOR	4
17	MJ-CONTURA-SCRPR-MOD	SCRAPER MOUNT	4
18	MJ365-D-0011_MIR	REAR DEFLECTOR	1
19	MJ365-D-0014	RUBBER FLAP CLAMP	1
20	MJ365-RUBBER FLAP	RUBBER FLAP	1
21	MJ60-200-HG02	HEIGHT GUIDE	4
22	MJ365-D-0010	AERO-FOIL (360 WING)	1
23	MJ365-D-0011	REAR DEFLECTOR	1
24	MJ75-360-CVR05	MJ75-360 WING COVER	1
25	SW2-550-CV21	GUARD BASE MOUNT	2
26	2000CM-GBM01	CENTER BOX MOUNT	1
27	8400RM-HG76	HEIGHT PIVOT BLOCK	8
28	8400RM-HG77	M20 HEX ADJUSTER	4
29	12HEX109	1/2F HEX 10.9	12
30	12x112FSKS	1/2"x1 1/2" FINE SOCKET HEAD 12.9	12
31	190.000.545	PTO GUARD (EXTENDED OVAL)	1
32	190592	PTO HAT	2
33	5/8F	5/8" FINE NYLOC NUT	12
34	58x2FBZP	5/8"x2" FINE BOLT	12
35	851	GREASE NIPPLE M8x1.25 STR	4
36	870	GREASE NIPPLE M8x90x1.25P	4

37	CP176-181MG1	45mm INSERT	3
38	CW39174	DISC SPRING 39x17x4 (YELLOW)	8
39	FWM10	M10 FLAT WASHER	2
40	FWM12	M12 FLAT WASHER	91
41	FWM12XL	M12 FLAT WASHER (EX-LARGE)	4
42	FWM16	M16 FLAT WASHER	12
43	FWM8	M8 FLAT WASHER	20
44	M10	M10 NYLOC NUT	2
45	M12	M12 NYLOC NUT	62
46	M12x30SKBH	M12x30 SOCKET BUTTON HEAD 10.9	31
47	M12x30SZP	M12x30 SET BOLT	8
48	M12x35SKBH	M12x35 SOCKET BUTTON HEAD 10.9	11
49	M12x40BZP	M12x40 BOLT	8
50	M12x60BZP	M12x60 BOLT	8
51	M16	M16 NYLOC NUT	4
52	M16HEX	M16 PLAIN NUT	4
53	M16x50SZP	M16x50 SET BOLT	8
54	M8	M8 NYLOC NUT	8
55	M8x16SKBH	M8x16 SOCKET BUTTON HEAD 10.9	8
56	M8x16SZP	M8x16 SET BOLT	12
57	NL12SP	M12 SP NORDLOCK	16
58	S1215	ROLL PIN DIA 6x40	8
59	WN365	DIA 50x40xM10 BUFFER	2

MJ75-360 Right Wing Assembly (MJ75-360-WGGA)

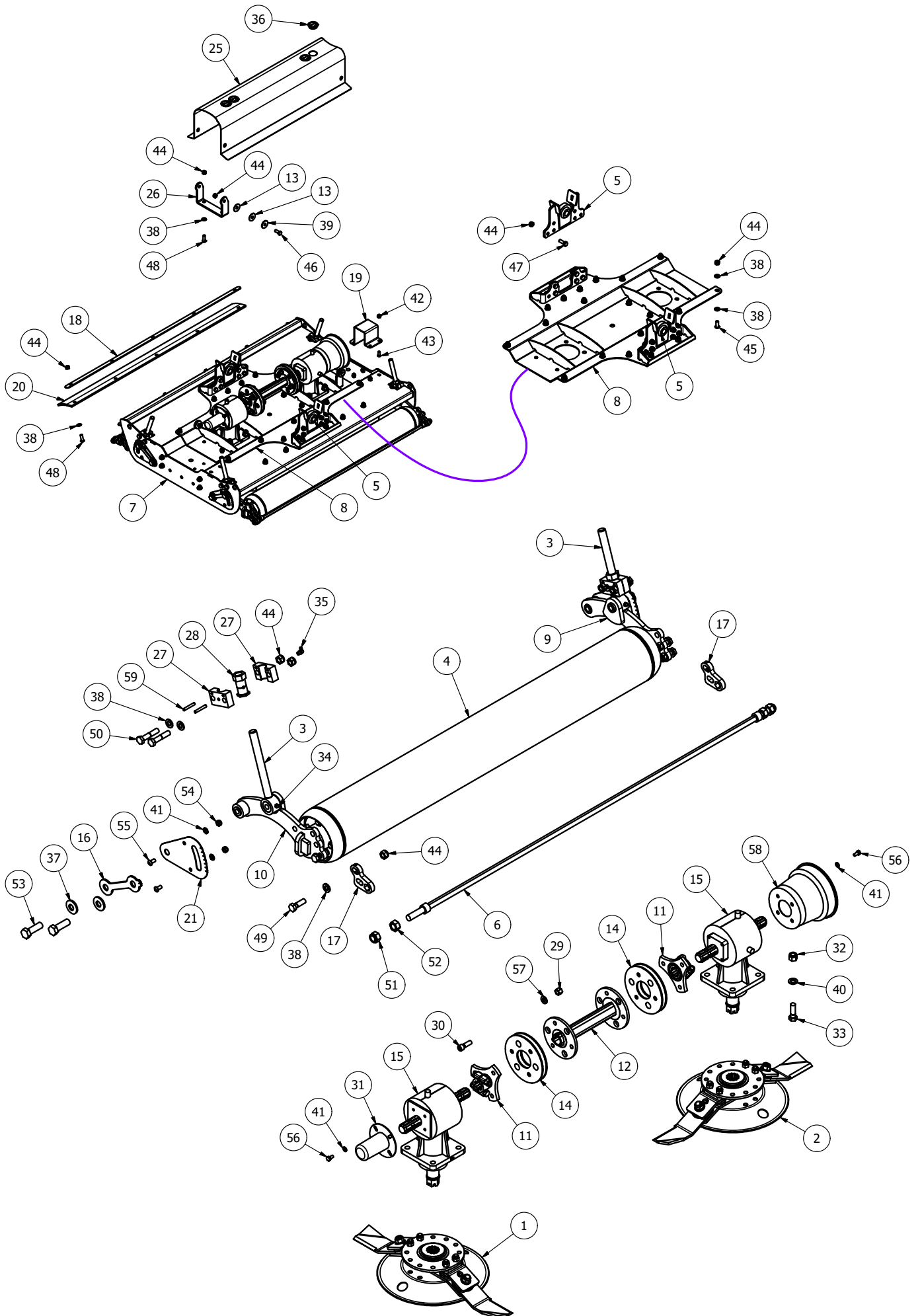

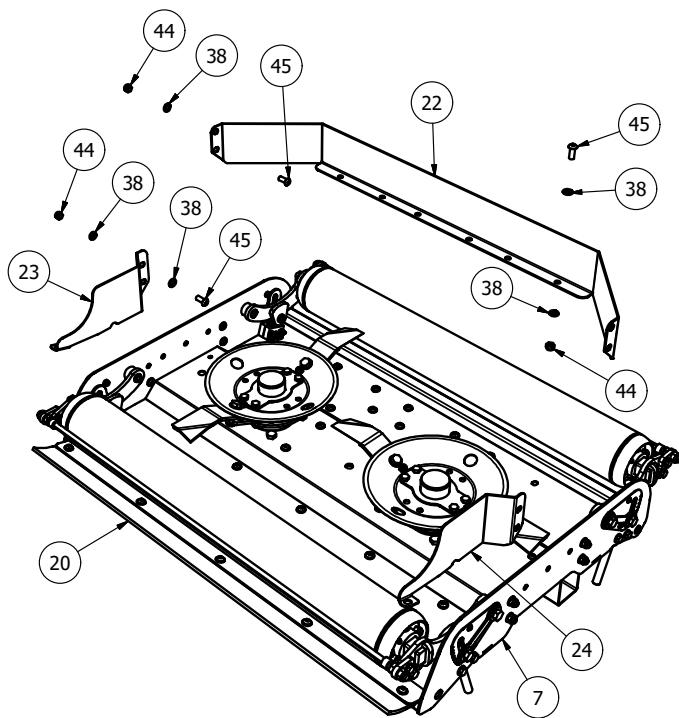

28	8400RM-HG77	M20 HEX ADJUSTER	4
29	12HEX109	1/2" HEX 10.9	12
30	12x112FSKS	1/2"x1 1/2" FINE SOCKET HEAD 12.9	12
31	190592	PTO HAT	1
32	5/8F	5/8" FINE NYLOC NUT	8
33	58x2FBZP	5/8"x2" FINE BOLT	8
34	851	GREASE NIPPLE M8x1.25 STR	4
35	870	GREASE NIPPLE M8x90x1.25P	4
36	CP176-181MG1	45mm INSERT	4
37	CW39174	DISC SPRING 39x17x4 (YELLOW)	8
38	FWM12	M12 FLAT WASHER	101
39	FWM12XL	M12 FLAT WASHER (EX-LARGE)	4
40	FWM16	M16 FLAT WASHER	8
41	FWM8	M8 FLAT WASHER	16
42	M10	M10 NYLOC NUT	4
43	M10x25SKBH	M10x25 SOCKET BUTTON HEAD 10.9	4
44	M12	M12 NYLOC NUT	80
45	M12x30SKBH	M12x30 SOCKET BUTTON HEAD 10.9	39
46	M12x30SZP	M12x30 SET BOLT	4
47	M12x35BZP	M12x35 BOLT	12
48	M12x35SKBH	M12x35 SOCKET BUTTON HEAD 10.9	9
49	M12x40BZP	M12x40 BOLT	8
50	M12x60BZP	M12x60 BOLT	8
51	M16	M16 NYLOC NUT	4
52	M16HEX	M16 PLAIN NUT	4
53	M16x50SZP	M16x50 SET BOLT	8
54	M8	M8 NYLOC NUT	8
55	M8x16SKBH	M8x16 SOCKET BUTTON HEAD 10.9	8
56	M8x16SZP	M8x16 SET BOLT	8
57	NL12SP	M12 SP NORDLOCK	12
58	NT20A	PTO GUARD (RND)	1
59	S1215	ROLL PIN DIA 6x40	8

Item	Part No	Description	Qty
1	680-DCBLDLK-L	680mm LOCK BLADE (Anti-CLK)	1
2	680-DCBLDLK-R	680mm LOCK BLADE (CLK)	1
3	8400RM-HG65	M20 THREADED ADJUSTER	4
4	CTR-360-WGROL	360 WING ROLLER	2
5	MJ365-D-EYE	DECK PIVOT EYE	2
6	MJ75-360-WSCRPR-01	360 CONTOURA SCRAPER	2
7	MJ75-360-WG01	360 WING DECK (RH)	1
8	MJ75-360-WG30	360 WING TROUGH	1
9	CTR-RPV10	ROLLER PIVOT	2
10	CTR-RPV20	ROLLER PIVOT	2
11	DRV-6S-52DC	6 SPLINE 52mm DRIVE	2
12	DRV-RC-MJ365	MJ70-365 DRIVE	1
13	MJ40-270-RW01	RUBBER WASHER	8
14	MJRC-23	113 PCD COUPLING 4mm PLT	2
15	S3035230012	6 SPLINE 'T' BOX RATIO 2.3	2
16	8400RM-HG03	HEIGHT INDICATOR	4
17	MJ-CONTURA-SCRPR-MOD	SCRAPER MOUNT	4
18	MJ365-D-0014	RUBBER FLAP CLAMP	1
19	MJ365-D-0017	ROLLER RUBBING PLATE	1
20	MJ365-RUBBER FLAP	RUBBER FLAP	1
21	MJ60-200-HG02	HEIGHT GUIDE	4
22	MJ365-D-0010	AERO-FOIL (360 WING)	1
23	MJ365-D-0011	REAR DEFLECTOR	1
24	MJ365-D-0011H	REAR DEFLECTOR	1
25	MJ75-360-CVR02	MJ75-360 WING COVER	1
26	SW2-550-CV21	GUARD BASE MOUNT	2
27	8400RM-HG76	HEIGHT PIVOT BLOCK	8

MJ75-360 Left Wing Assembly (MJ75-360-WGLGA)

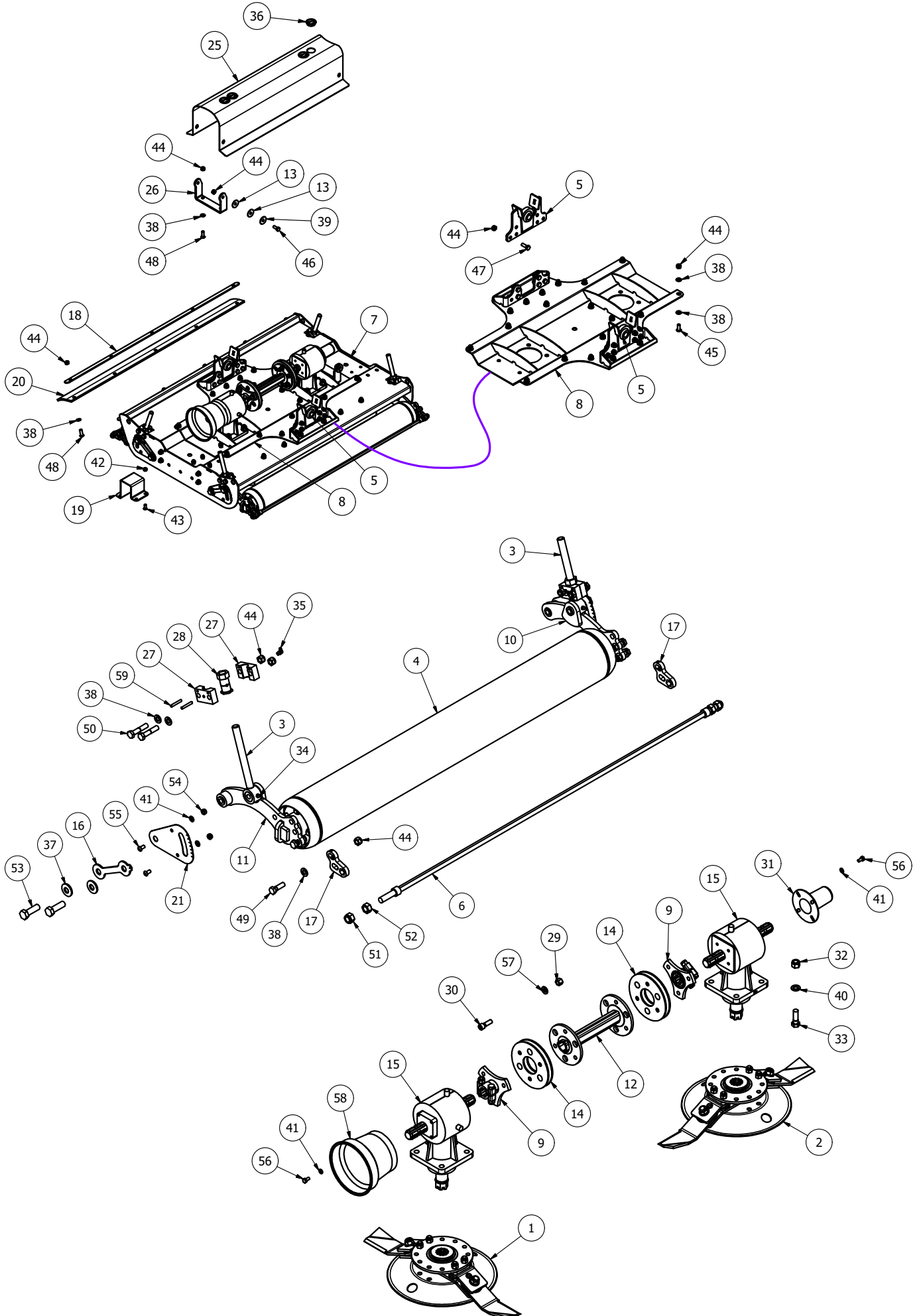

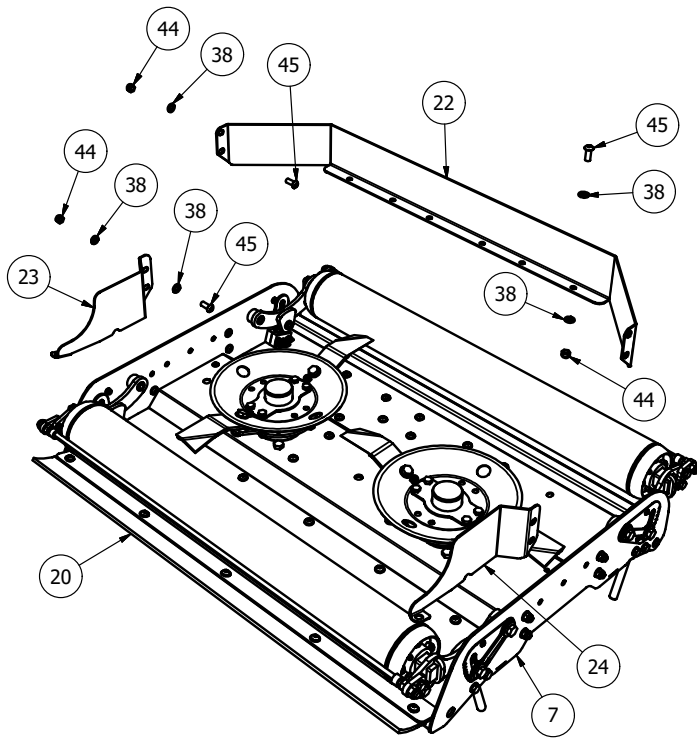

28	8400RM-HG77	M20 HEX ADJUSTER	4
29	12HEX109	1/2F HEX 10.9	12
30	12x112FSKS	1/2"x1 1/2" FINE SOCKET HEAD 12.9	12
31	190592	PTO HAT	1
32	5/8F	5/8" FINE NYLOC NUT	8
33	58x2FBZP	5/8"x2" FINE BOLT	8
34	851	GREASE NIPPLE M8x1.25 STR	4
35	870	GREASE NIPPLE M8x90x1.25P	4
36	CP176-181MG1	45mm INSERT	4
37	CW39174	DISC SPRING 39x17x4 (YELLOW)	8
38	FWM12	M12 FLAT WASHER	101
39	FWM12XL	M12 FLAT WASHER (EX-LARGE)	4
40	FWM16	M16 FLAT WASHER	8
41	FWM8	M8 FLAT WASHER	16
42	M10	M10 NYLOC NUT	4
43	M10x25SKBH	M10x25 SOCKET BUTTON HEAD 10.9	4
44	M12	M12 NYLOC NUT	80
45	M12x30SKBH	M12x30 SOCKET BUTTON HEAD 10.9	39
46	M12x30SZP	M12x30 SET BOLT	4
47	M12x35BZP	M12x35 BOLT	12
48	M12x35SKBH	M12x35 SOCKET BUTTON HEAD 10.9	9
49	M12x40BZP	M12x40 BOLT	8
50	M12x60BZP	M12x60 BOLT	8
51	M16	M16 NYLOC NUT	4
52	M16HEX	M16 PLAIN NUT	4
53	M16x50SZP	M16x50 SET BOLT	8
54	M8	M8 NYLOC NUT	8
55	M8x16SKBH	M8x16 SOCKET BUTTON HEAD 10.9	8
56	M8x16SZP	M8x16 SET BOLT	8
57	NL12SP	M12 SP NORDLOCK	12
58	NT20A	PTO GUARD (RND)	1
59	S1215	ROLL PIN DIA 6x40	8

Item	Part No	Description	Qty
1	680-DCBLDLK-L	680mm LOCK BLADE (Anti-CLK)	1
2	680-DCBLDLK-R	680mm LOCK BLADE (CLK)	1
3	8400RM-HG65	M20 THREADED ADJUSTER	4
4	CTR-360-WGROL	360 WING ROLLER	2
5	MJ365-D-EYE	DECK PIVOT EYE	2
6	MJ75-360-WSCRPR-01	360 CONTOURA SCRAPER	2
7	MJ75-360-WG01	360 WING DECK (RH)	1
8	MJ75-360-WG30	360 WING TROUGH	1
9	60CSD	60mm STAR DRIVE	2
10	CTR-RPV10	ROLLER PIVOT	2
11	CTR-RPV20	ROLLER PIVOT	2
12	DRV-RC-MJ365	MJ70-365 DRIVE	1
13	MJ40-270-RW01	RUBBER WASHER	8
14	MJRC-23	113 PCD COUPLING 4mm PLT	2
15	S3035230012	6 SPLINE 'T' BOX RATIO 2.3	2
16	8400RM-HG03	HEIGHT INDICATOR	4
17	MJ-CONTURA-SCRPR-MOD	SCRAPER MOUNT	4
18	MJ365-D-0014	RUBBER FLAP CLAMP	1
19	MJ365-D-0017	ROLLER RUBBING PLATE	1
20	MJ365-RUBBER FLAP	RUBBER FLAP	1
21	MJ60-200-HG02	HEIGHT GUIDE	4
22	MJ365-D-0010	AERO-FOIL (360 WING)	1
23	MJ365-D-0011	REAR DEFLECTOR	1
24	MJ365-D-0011H	REAR DEFLECTOR	1
25	MJ75-360-CVR02	MJ75-360 WING COVER	1
26	SW2-550-CV21	GUARD BASE MOUNT	2
27	8400RM-HG76	HEIGHT PIVOT BLOCK	8

MJ75-360 Roller (CTR-360-WGROL)

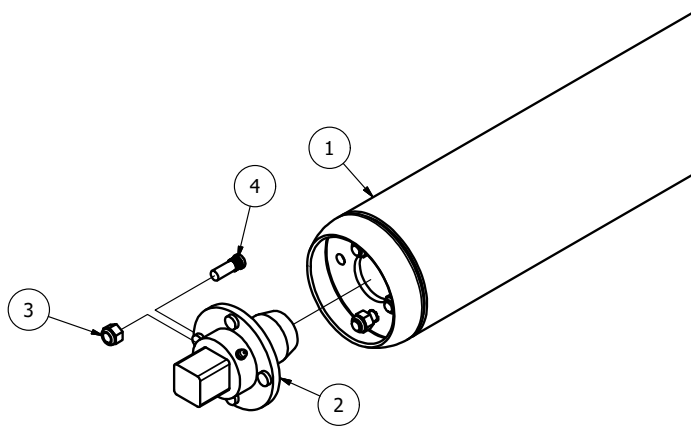

Item	Part No	Description	Qty
1	CTR-360-WGROL01	360 WING ROLLER	1
2	CTR-360-WGROL05	ROLLER AXLE STUB	2
3	22204	M12 WHEEL NUT	8
4	57112B1	M12 x 40 AXLE STUD	8

Blades MJ75
680-DCBLDLK-L

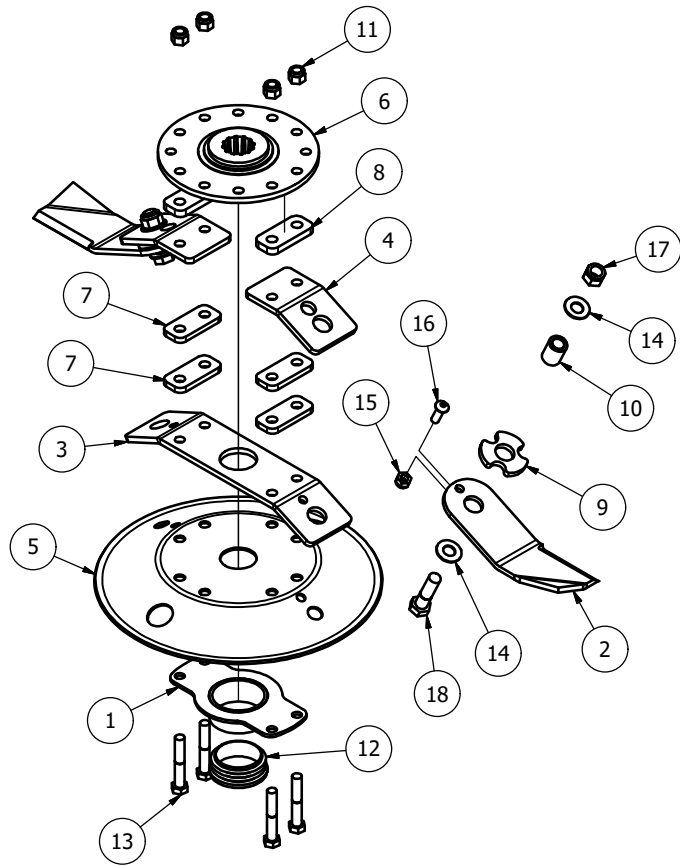

680-DCBLDLK-R

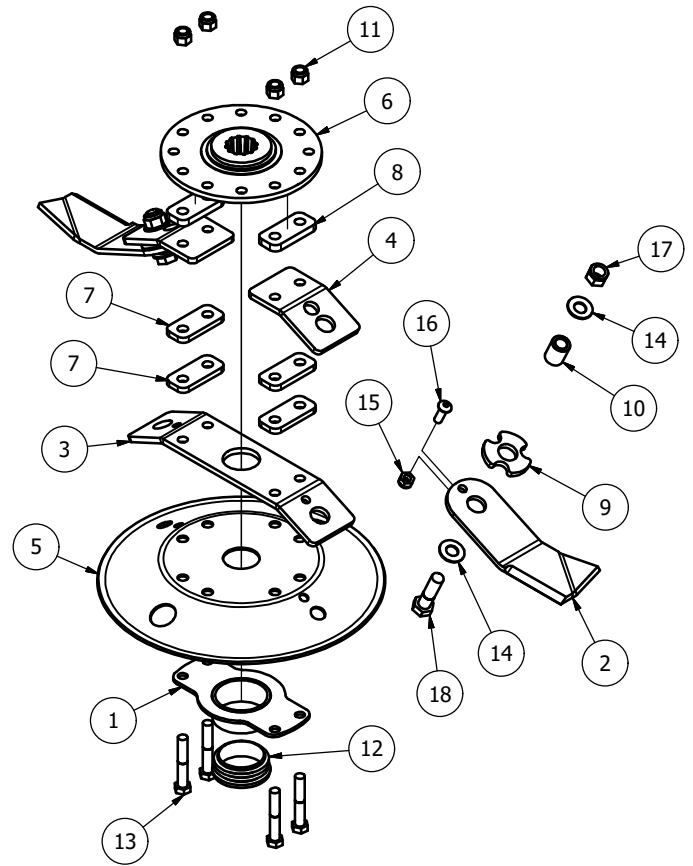

Item	Part No	Description	Qty
1	DISC-315-25-10	ROTOR NUT CAP	1
2	BLD-24225-AC-LCK	BLADE 242xDia 25 (Anti-Clk)	2
3	BLDB-294-25-SY2-LCK	BLADE BACK (294 CTR 25 deg)	1
4	BLDB-315-25-SY2-LCK	BLADE BACK (315 CTR 25 deg)	2
5	DISC-315-25	DISC (315 BLADE 25 deg)	1
6	RM2-BMAX-MK2	BLADE MOUNT RM2	1
7	BLDB-315-25-SY2SP08	8mm SPACER	4
8	BLDB-315-25-SY2SP10	10mm SPACER	2
9	RM2-SP-LCK	BLADE SPACER LOCK	2
10	BB25-16-32	BLADE BUSH	2
11	1/2F	1/2" FINE NYLOC NUT	4
12	111072	DIA 66-72mm INSERT	1
13	12x3FBZP	1/2"x3" FINE BOLT	4
14	DSW34	DISC SPRING 34x16.3x2	4
15	M10	M10 NYLOC NUT	2
16	M10x30SKBH	M10x30 SOCKET BUTTON HEAD 10.9	2
17	M16	M16 NYLOC NUT	2
18	M16x60BZP	M16x60 BOLT	2

Item	Part No	Description	Qty
1	DISC-315-25-10	ROTOR NUT CAP	1
2	BLD-24225-C-LCK	BLADE 242xDia 25 (Clk)	2
3	BLDB-294-25-SY2-LCK	BLADE BACK (294 CTR 25 deg)	1
4	BLDB-315-25-SY2-LCK	BLADE BACK (315 CTR 25 deg)	2
5	DISC-315-25	DISC (315 BLADE 25 deg)	1
6	RM2-BMAX-MK2	BLADE MOUNT RM2	1
7	BLDB-315-25-SY2SP08	8mm SPACER	4
8	BLDB-315-25-SY2SP10	10mm SPACER	2
9	RM2-SP-LCK	BLADE SPACER LOCK	2
10	BB25-16-32	BLADE BUSH	2
11	1/2F	1/2" FINE NYLOC NUT	4
12	111072	DIA 66-72mm INSERT	1
13	12x3FBZP	1/2"x3" FINE BOLT	4
14	DSW34	DISC SPRING 34x16.3x2	4
15	M10	M10 NYLOC NUT	2
16	M10x30SKBH	M10x30 SOCKET BUTTON HEAD 10.9	2
17	M16	M16 NYLOC NUT	2
18	M16x60BZP	M16x60 BOLT	2

MJ75-360 3 off

MJ75-360 3 off

S3035230012-2.30

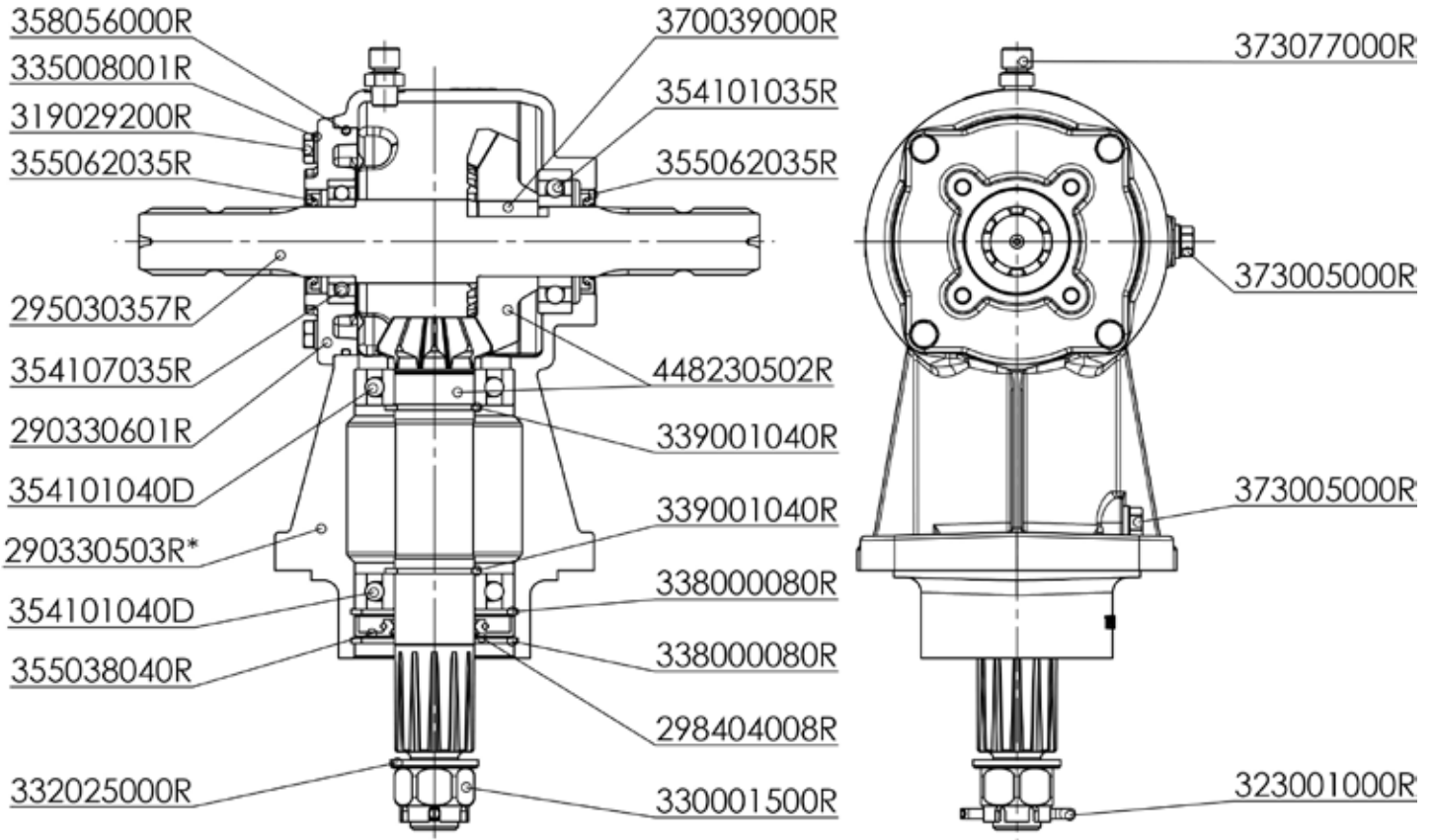

Item	Part No	Description	Qty	Euro
1	290330503R	HOUSING 3035 -R- D.123.5	1	
2	290330601R	COVER	1	
3	295030357R	SHAFT	1	
4	298404008R	SEALING LID	1	
5	319029200R	SCREW HEX HEAD M8x25x1.25 UNI5739 S8422	4	
6	323001000R	COTTER PIN 5X50 UNI 1336	1	
7	330001500R	CASTLE NUT M24x2 UNI5593	1	
8	332025000R	WASHER	1	
9	335008001R	LOCK WASHER M8 (8.1x14.8x1.6) DIN128B	4	
10	338000080R	CIRCLIP INTERNAL 80x2.50 DIN472	2	
11	339001040R	CIRCLIP EXTERNAL 40x2.50 DIN471/2 THICK	2	
12	354101035R	BALL BEARING 35x72x17 6207	1	
13	354101040DR	BALL BEARING 40x80x18 6208 -SKF-	2	
14	354107035R	BEARING CUSC.6007 35x62x14 SF.D.Q.	1	
15	355038040R	OIL SEAL 40x80x10 FPM/FKM	1	
16	355062035R	OIL SEAL 035X052X007 PAR VITON-D.Q.	2	
17	358056000R	OIL SEAL	1	
18	370039000R	KEY	1	
19	373005000R	PLUG 3/8" BSPT (GAS) HEX HEAD ZINC	2	
20	373077000R	PLUG 1/4" BSPT (GAS) BREATHER	1	
21	448230502R	BEVEL GEAR	1	