

ELLIETT®

MANUAL

Prof 6



This manual contains specific information regarding the use and maintenance of the machine. **Read it carefully and keep it in a safe place.**



Please also keep your **purchase invoice** or proof of payment along with this manual.



Register your purchase online at **www.eliyet.eu**

© ELIET

Copyright 2020 ELIET. All rights reserved. All textual material, illustrations and other content included in this manual are protected by copyright and other intellectual property rights. No part of this manual may be used for commercial purposes. Certain sections of this manual are also protected by the copyright of ELIET's suppliers.

1. Introduction



1.1. Read this manual

ELIET machines are designed for safe and reliable use, if they are operated in accordance with the instructions provided. Carefully read this manual before using the machine. Neglecting to do so could result in bodily injury or material damage.

1.2. Identification data - ELIET Prof 6

Write the identification data of your machine in the boxed areas:

Type number:

Engine:

Serial number:

Year of Manufacture:

2. Warranty



2.1. Registering your machine

In order to be able to make a warranty claim, you will need to register your machine online within one month after purchase: **www.elieta.eu**

European customers:

ELIET EUROPE S.A.

Diesveldstraat 2

8553 Otegem

T (+32)(0)56 77 70 88 - **F** (+32)(0)56 77 52 13

e-mail: info@elieta.eu, www.elieta.eu

U.S. customers:

ELIET USA Inc.

3361 Stafford Street

Pittsburgh, PA 15204

Ph +1 412 367 5185 - **Fax** +1 412 774 1970

e-mail: info@elietausa.com, www.elietausa.com

Read the warranty conditions (see Section 17, page 82)

3. Welcome



Welcome to the family of ELIET customers.

We would like to thank you for the confidence that you have placed in ELIET and we are convinced that you have purchased the very best machine. The operating life of your ELIET machine depends to a great extent on how you use your machine. This user manual and the engine manual that has also been provided with your machine will assist you in this respect. If you follow the instructions and suggestions in these manuals, you can be assured that your ELIET machine will operate for a very long time in optimal condition.

We recommend that you carefully read this manual. This will prevent any incorrect operation of the machine that might have serious consequences.

It is also in your best interest to carefully read the chapter specific to safety instructions. Even if you are thoroughly familiar with operating this type of machine, it is still strongly recommended that you carefully read this manual.

At ELIET, we are constantly in the process of perfecting our machines and equipment. As such, all of our products are subject to slight modifications, both in regards to their configuration and accessories, as well as to the included technology. The descriptions and technical data in this manual are accurate as of the time of printing. Certain illustrations and descriptions may not be applicable to the machine that you have purchased, but instead relate to a different version of the machine. As such, we trust that you will understand that we take no responsibility for claims made in regards to the text and illustrations included in this manual. If you still have questions after having read this manual, please do not hesitate to contact your ELIET dealer. You will find an authorised ELIET dealer near you at **www.elieta.eu**.

ELIET AT YOUR SERVICE

During office hours, the ELIET helpdesk is always at your service to answer your questions:

European customers:

GMT +1: from 8:00 a.m. to 4:00 p.m.

Telephone: +32 56 77 70 88

Fax: +32 56 77 52 13

info@elieta.eu

www.elieta.com

U.S. customers:

GMT -5: 8 a.m. to 5 p.m.

Ph +1 412 367 5185

Fax +1 412 774 1970

info@elietausa.com

www.elietausa.com

OPERATING FORESTRY, PARK AND GARDEN POWER EQUIPMENT

Under the laws of several countries and states, it is unlawful to operate an internal combustion engine that uses hydrocarbon fuels on any forest-covered, brush-covered or grass-covered land or on land where grain, hay or any other flammable agricultural crop is grown without a properly functioning spark arrestor.

Like with most outdoor power equipment, the engine in your power equipment is an internal combustion engine that burns petrol (UK)/ gas (USA), a hydrocarbon fuel. Therefore, your power equipment must be equipped with a spark arrestor muffler that is in continuous, effective working order. The spark arrestor must be attached to the engine exhaust system in such a way that flames are prevented from escaping the system and from coming into contact with flammable material.

Failure on the part of the owner/operator of the machine to comply with this regulation is a misdemeanor under certain law (e.g., Californian Law), and may also be a violation of other national and/or federal regulations, laws, ordinances, or codes. Contact your local chief fire officer or forest ranger for specific information about the applicable regulations in your area.

The standard muffler installed on ELIET engines is not equipped with a spark arrestor. One must be added before operation if the machine is to be used in an area where a spark arrestor is required by law. Please contact your local authorities to find out if these laws apply to you. Please contact your authorised dealer to learn more about the spark arrestor options that are available to you.

ELIET®

4. Table of Contents

1. Introduction	3
1.1. Read this manual.....	3
1.2. Identification data - ELIET Prof 6	3
2. Warranty.....	3
2.1. Registering your machine.....	3
3. Welcome.....	4
4. Table of Contents.....	6
5. Safety symbols.....	9
5.1. For your information	9
5.2. Caution	9
5.3. Warning.....	9
6. Main parts	10
6.1. Overview.....	10
7. Safety precautions.....	13
7.1. Safety messages.....	13
7.2. Safety features	18
7.3. Safety precautions.....	20
7.3.1. General safety precautions	20
7.3.2. Careful and sensible use.....	21
7.3.3. Responsibilities of the operator.....	21
7.3.4. Personal Protective Equipment (PPE).....	22
7.3.5. Danger zone	23
7.3.6. Regular maintenance	23
7.3.7. Respect the environment	24
8. Responsibilities of the dealer	25
9. Manual	26
9.1. Preliminary checks.....	26
9.2. Filling up with fuel.....	27
9.3. Preparing the work area.....	28
9.4. Starting and turning off the engine.....	29
29engine	<?>
9.5. Moving the machine	31
9.6. Working with the machine	34
9.6.1. Before you start working.....	34
9.6.2. Turning and positioning the blow chute and deflector	35
9.6.3. While working.....	36
9.6.4. Operating the feed roller	36
9.7. After working	40
9.7.1. Cleaning the machine.....	40
9.8. Lifting the machine (ZR and Cross Country).....	41
10. Transporting the machine	44

11. Maintenance	46
11.1. General	46
11.2. Maintenance schedule	48
11.2.1. Special maintenance	49
11.2.2. Daily maintenance.....	50
11.2.3. Maintenance after 5 hours of use	50
11.2.4. Maintenance after 10 hours of use.....	50
11.2.5. Maintenance after 25 hours of use	50
11.2.6. Maintenance after 50 hours of use.....	51
11.2.7. Maintenance after 100 hours of use (or every six months).....	51
11.2.8. Maintenance after 200 hours of use (or annually)	51
11.2.9. Maintenance after 400 hours of use.....	51
11.3. Miscellaneous interventions.....	52
11.3.1. Removing the belt cover.....	52
11.3.2. Removing the chain guard.....	52
11.3.3. Disconnecting the battery.....	53
11.3.4. Opening the blade shaft compartment.....	53
11.3.5. Setting the blow chute to the working or lowered position	54
11.3.6. Manually lifting the feed roller	55
11.4. Engine maintenance.....	56
11.4.1. Checking engine oil level + refilling	56
11.4.2. Changing the engine oil	57
11.4.3. Cleaning the air filter.....	57
11.4.4. Replacing the air filter	58
11.4.5. Changing the engine fuel filter	58
11.4.6. Refilling the hydraulic fluid	58
11.4.7. Changing the hydraulic fluid filter	59
11.5. Machine maintenance	61
11.5.1. Routine inspection of the blades.....	61
11.5.2. Sharpening the blades	62
11.5.3. Turning or replacing the blades.....	64
11.5.3.1. How to turn a blade	65
11.5.3.2. How to replace a blade	67
11.5.4. Checking the tension of the drive belt.....	69
11.5.5. Checking the alignment of the pulleys / Replacing the belt.....	69
11.5.6. Checking the tension of the feed roller transmission chain	70
11.5.7. Checking and adjusting the tension of the tracks (Cross Country model).....	71
11.5.8. General lubrication.....	72
11.5.8.1. Lubrication of pivot points and friction surfaces.....	72
11.5.8.1.1. This group includes the following locations on the machine:	72
11.5.8.13. Lubricating using the grease fittings	73
11.5.8.14. Lubricating the bearings.....	74
11.5.8.15. Lubricating the chains and sprockets.....	75

12. Storing the machine.....	76
13. Options	77
14. Risks	78
15. Equipment specifications	80
16. EC Declaration of Conformity	81
17. Appendices	82
17.1. Specifications for lubricants and fuel	82
17.2. Torque chart	83
17.3. Error identification	84
17.4. Troubleshooting.....	86
17.4.1. Blade shaft becomes blocked.....	86
17.4.2. Engine shuts off.....	86
17.4.3. Engine stalls.....	86
17.4.4. Starter does not react while starting engine.....	86
17.4.5. Capacity decreases	86
17.4.6. Wheel drive does not function while petrol (UK)/ gas (USA) engine is running.....	86
17.4.7. Feed roller no longer functions.....	87
17.4.8. Engine shuts off and the machine must be moved - ZR model	87
18. Warranty conditions.....	88

5. Safety symbols

ELIET cannot foresee every situation which may represent a risk or danger. As such, the warnings in this manual, as well as the stickers placed on the machine, are not exhaustive. Though very minimal, there is some residual risk. If you, as the operator, utilise any procedure or technique, or execute any operation that is not explicitly recommended by ELIET, please ensure that you are not putting anyone else at risk.



The symbols used in this manual ("For your information", "Caution", "Warning") are meant to provide you with further information and to draw your attention to any potential danger.

5.1. For your information



For your information: This symbol is meant to draw your attention to special information and/or actions, or to inform you that additional information on a particular topic is also available elsewhere in the manual.

5.2. Caution



Caution: This symbol explains how to proceed in order to avoid incorrect handling. This will allow you to avoid any incorrect actions that could lead to bodily injury or material damage.

5.3. Warning



Warning: This symbol is meant to draw your attention to very serious risks of which you need to be aware in certain circumstances. In these cases, please remain alert, in order to ensure your own safety.

These security messages are only meant to inform the operator; in no way do they eliminate risk. Common sense and following the instructions in this manual are essential to avoiding accidents.

6. Main parts

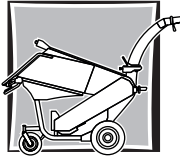

To fully understand the content of this manual, it is important for you to be familiar with the terminology used in the descriptions. This chapter includes a rundown of various parts and identifies them by name. It is strongly recommended that you examine the machine before operation, in order to fully understand the descriptions that are provided in this manual.

6.1. Overview

1. Feed hopper
2. Safety button
3. Safety bar
4. Feed roller controls
5. Petrol (UK)/ gas (USA) tank filler cap
6. Ignition key
7. Engine controls
8. Feed drive
9. Turbine system
"Turbo Discharge™"
10. Locking handle for rotating the
blow chute
11. Deflector handle

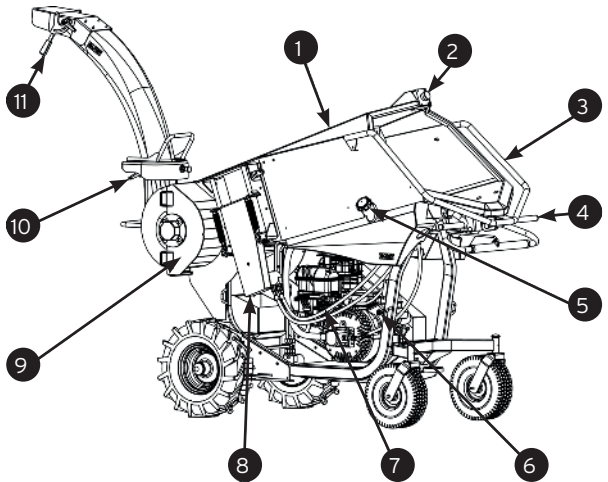

1. Handle + control panel
2. Locking button for lowering the blow chute
3. Blow chute
4. Maintenance hatch
5. Transmission belt guard
6. Traction wheel
7. Swivel wheel
8. Brake pedal
9. Hydraulic oil filler plug

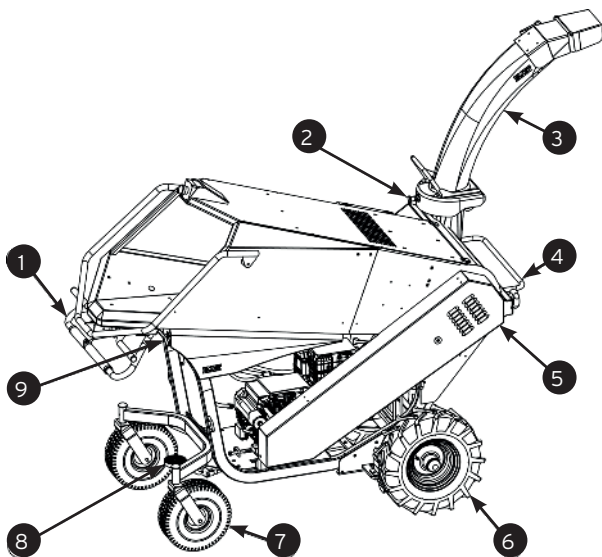

1. "Turbo Discharge™" fan
2. Blade support/shaft
3. Feed roller
4. Anti-projectile shield
5. Feed roller speed regulator (option)
6. Battery

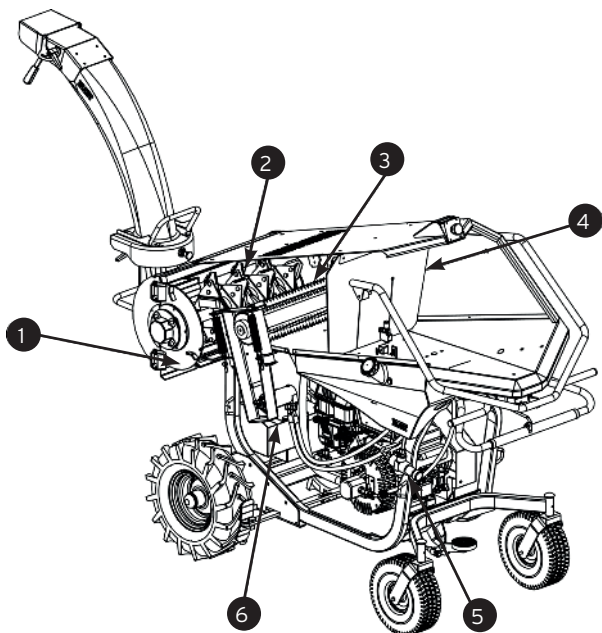

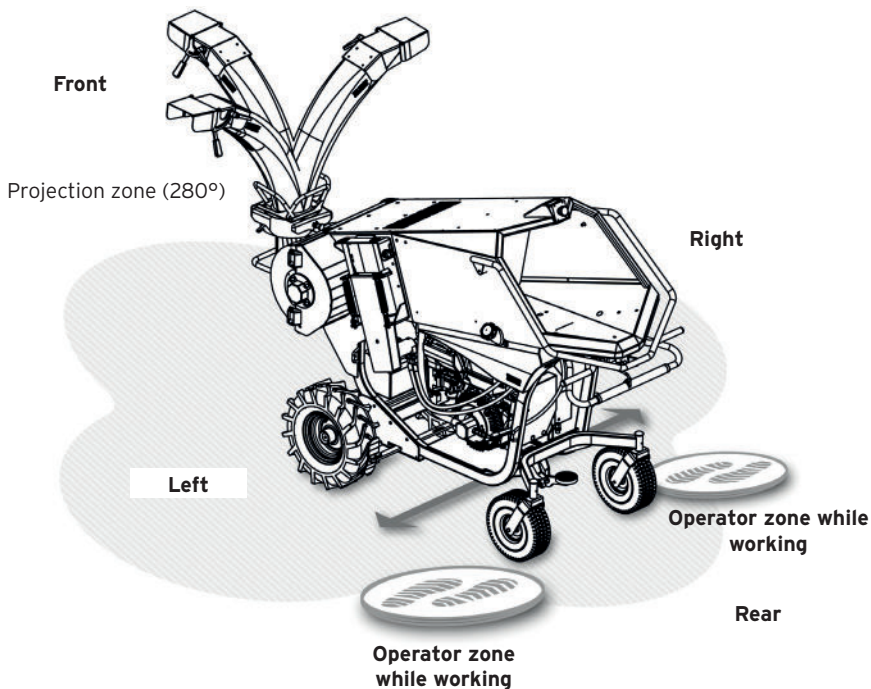

For your information: When the instructions in this manual indicate "right, left, front and behind", this is always to be interpreted from the point of view of an operator standing on the feeding side of the machine.



For your information: Your ELIET dealer is at your service to provide you with advice and to assist with the maintenance of your machine so that it always remains in optimal condition. You can also contact your dealer with all of your parts and lubricant needs. These service parts are manufactured with the same know-how and precision as the original equipment.



Caution: For your own safety, only original equipment parts should be used on ELIET machines.

7. Safety precautions

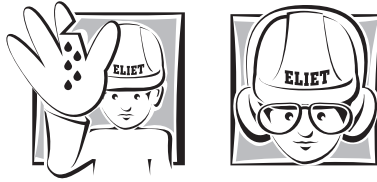

7.1. Safety messages

Security messages in the form of stickers or embossed illustrations can be found at easily visible locations on your machine. Please pay special attention to the pictograms and warning messages they contain.

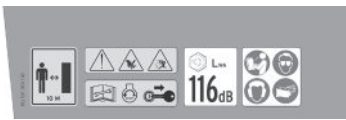

1. Stickers **(1)** and **(2)** are located on the left side of the Prof 6.
 - Sticker **(1)** summarises the general safety instructions in the form of icons:
 - You have to read and fully understand the instruction manual before working with the machine. Always wear the appropriate protective gear while operating the machine (gloves, safety goggles, hearing protectors).
 - Sticker **(2)** is a reminder to keep any bystanders present at a safe distance (10 m - 30 ft).
 - The inscription indicates the guaranteed sound power level (Lw(A) emitted by the machine under standard conditions. (116 dB)
 - This sticker indicates that, during maintenance, the engine must be turned off and the ignition key must be removed. (item code: BQ 501 050 190)



2. Likewise, the sticker located on the right side of the hopper highlights the risk of cutting one's hands and being pulled into the hopper. These two risks are inherent to the shredding of wood, but the presence of the anti-projectile shield ensures the maximum reduction of both. Wearing gloves is mandatory, and you must never place your legs into the hopper or climb into it. (item code: BQ 505 010 565)

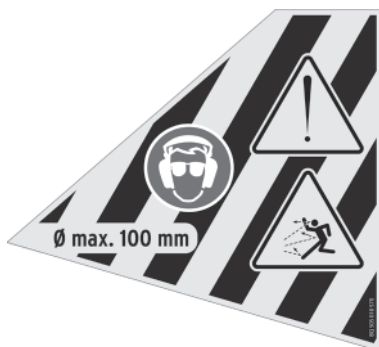

3. The sticker located on the left side of the hopper is a reminder of the maximum diameter of a branch that can be shredded (<10 cm - 4"). There is a risk of wood chips being ejected from the hopper. Anyone standing within 10 metres - 30 ft of the machine must be wearing safety goggles while the engine is running. (item code: BQ 505 010 570)



4. This sticker located on the belt guard indicates that a belt is found behind the guard. The machine is never to be operated with the safety guard removed, as this could lead to the operator's hands being crushed. Before any interventions on the machine, please carefully read the maintenance manual. You must wait a minimum of 1 minute after shutting off the machine to make sure that all moving parts have completely stopped before undertaking any interventions. For all maintenance operations, the engine must be turned off and the operator must refer to the user manual. Never operate the machine without all the safety guards mounted in place. (item code: BQ 505 010 600)



5. This sticker is located on the deflector and contains a warning related to the risk of injury that could occur if you are standing within the shredder ejection zone while the engine is running. This apply to anyone standing within 10 metres - 30 ft of the machine. (item code: BQ 505 014 100)



6. The blow chute can be folded over in order to make the unit smaller for transport. This sticker, located on the blow chute and the shredding chamber, warns the operator of the danger of either catching or cutting their fingers while folding the chute. The sticker also indicates that it is necessary to first turn off the engine before folding the chute. Your hands should never be placed into the blow chute or the shredding chamber for any reason. There is an imminent risk of wood chips being ejected from the blow chute. (item code: BQ 501 050 270 and BQ 505 010 590)

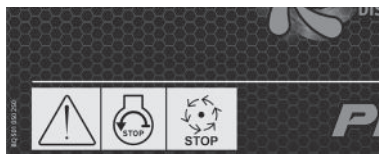

7. This sticker, located on the shredding chamber, warns the operator of the danger of being cut by the blades when opening the maintenance hatch that provides access to the blade system. The engine must be turned off, and the operator must ensure that the blade shaft has come to a complete stop. You must wait a minimum of 1 minute after shutting off the machine to make sure that all moving parts have completely stopped before undertaking any interventions.
(item code: BQ 501 050 250)



8. This sticker, located on the hopper, is a reminder to the operator to check the bolts that attach the blades to the shaft 5 hours after having terminated an intervention on the machine (either changing or turning the blades). The operator must turn off the engine and remove the ignition key. When performing maintenance on the blades, you must ensure that the blade shaft has come to a complete stop. Due to the heightened risk of cutting your hands, you must wear protective gloves and read the maintenance manual, in order to ensure the use of the proper wrenches.
(item code: BQ 505 010 420)



9. The sticker located on the belt guard towards the engine exhaust pipe indicates a risk of burning oneself in this area.
(item number: BQ 505 010 580)



10. The sticker located on the support mechanism guard of the vertically-sliding feeder indicates a risk of catching or crushing your fingers. Maintain a safe distance for all susceptible body parts. This sticker located on the feeding mechanism guard also indicates that a chain is found behind it. Once the guard has been removed, there is a risk of susceptible body injury being dragged into the machine. Never operate the machine without all the safety guards mounted in place.
(item code: BQ 501 050 280)

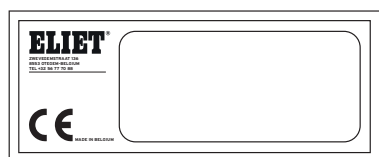

11. This sticker is located on the battery holder. It contains all identification data for your machine: model, model number, serial number, year of manufacture, engine, power rating, weight, guaranteed sound power level (Lw(A)). This sticker also contains all information related to the manufacturer. The CE label also indicates that the machine complies with the current European Machinery Directive.



12. The sticker located just above the engine is a reminder that a high-pressure cleaner must never be used on the sensitive areas of the machine: engine, transmission, bearings, electrical junction box, etc.
Do not clean the machine when it is still warm.
(item code: BQ 505 010 465)

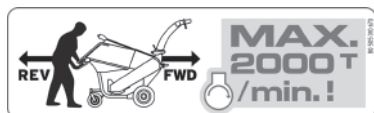

13. This sticker on the chassis in front of the engine strongly advises you to reduce the engine RPM to **maximum** 2000 when you will move the unit around.
(item code: BQ 505 010 670)



Caution: Safety stickers or any parts that bear such information that have either become damaged, removed or rendered illegible after operation or cleaning must be replaced immediately. These stickers and parts are available at your authorised ELIET dealer.

The following stickers apply exclusively to machines sold on the American market:

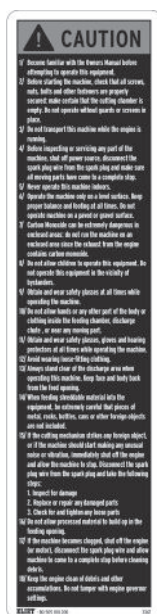

14. This sticker summarises a number of important safety messages taken from the instruction manual in 18 points. Caution: This of course does not relieve the operator of the obligation to read the instruction manual.
(item code: BQ 505 010 200)

15. This sticker is located on the battery holder. It warns the user of the hazard posed by the sulphuric acid contained within the battery (item code: BQ 505 010 180).



16. This sticker is located on the feeding hopper at the infeed opening. It is a standing reminder to the operator to operate the machine within the prescribed capacity and to not overload it (item code: BQ 505 010 190).



17. This sticker is located near the engine starter mechanism. Each time the operator goes to start the machine, they are reminded to inspect and service the blades regularly before turning on the machine (item code: BQ 505 010 250).

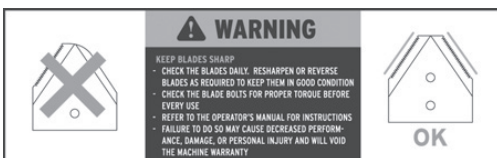

18. This sticker is found next to the identification sticker. It contains the phone number that our American customers can call in the event of a problem (item code: BQ 505 010 240).



7.2. Safety features

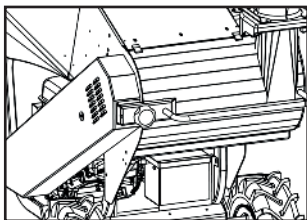

Safety switch:

The safety contact installed in the maintenance hatch of the blade shaft and the "Turbo Discharge™" prevents any contact with rotating parts. This maintenance hatch can be opened without the need for tools. When it is opened, the safety switch turns off the motor. The motor can only be restarted once the maintenance hatch has been closed properly.

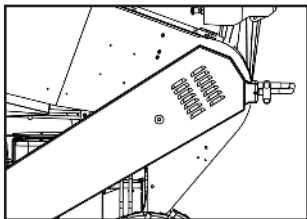

Belt guards:

These guards provide protection against the potential hazards created by rotating belts. They can only be removed with the use of tools. If the belt guards have been removed or are not fitted correctly, starting the machine is strictly prohibited given the potential safety hazards.

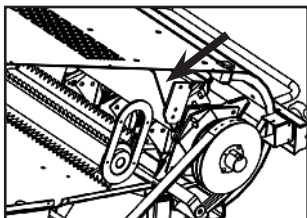

Sound absorption:

The soundproof hood around the blade shaft absorbs the noise created by shredding, which reduces the noise pollution to which the operator and their surroundings are exposed.

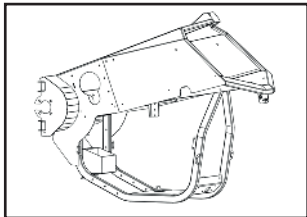

Sturdy construction:

Sturdy construction provides a guarantee of endurance for ELIET machines and is also a guarantee of user safety in the event of unexpected occurrences.

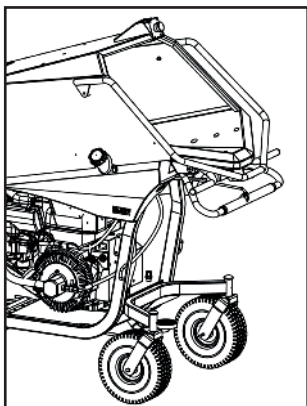

Safety bar and button:

If you press the safety bar or button, the feed roller will stop immediately. The feed roller can only be restarted once the safety bar or button has been returned to its original position.

To reset:

Safety button: Turn the button and pull.

Safety bar: Pull on the lock below the hopper, and pull the bar towards yourself.

Parking brake:

The parking brake ensures that the machine does not move while you are working or transporting it. The brake keeps the machine stationary in one spot, in order to avoid any potential mishaps after it has been moved.

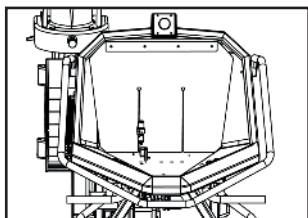
**Anti-projection shield:**

The flexible safety screen fitted inside the infeed opening protects the operator against flying wood chips. Under no circumstances should you place your hands beyond this flexible, transparent screen.

The operator must remain aware that lifting this screen means losing the protection it provides and increases risks of injuries. It is to be replaced in the event that it is damaged.

(item code: BR 902 000 010)

**Safety kit:**

Because we here at ELIET are concerned for your safety, we cannot insist enough the importance of using all of the protective gear included in the standard safety kit that we supply. This kit contains your Personal Protective Equipment (PPE): safety glasses, hearing protectors and a pair of multi-purpose gloves.



Warning: Never try to deactivate or avoid the safety features. The safety measures are meant for your own personal safety. Before beginning to work, the operator must verify that all protective equipment is functioning properly. In the event that a defect is detected, first complete any repairs that are necessary.

7.3. Safety precautions

7.3.1. General safety precautions



Warning: Most accidents are the result of reckless and thoughtless behaviour.

- The owner of the machine must keep this manual throughout the complete service life of the machine. It will serve as a reference for the operator for operating and maintaining the machine according to the proper instructions. Always refer to this instruction manual if you have any doubts about how to perform a certain operation.
- If the instructions stated in this manual are not clear, do not hesitate to contact your ELIET dealer for further clarification. ELIET's help desk is also at your disposal during office hours to answer your questions (EU +32 56 77 70 88).



For your information: Please also carefully read the engine manual that is provided with the machine. It contains useful information for properly using and maintaining the engine.

- Also read the chapter that is meant for the dealer (see Section 8, page 25) and immediately check if the machine has been delivered to you in accordance with the requirements.
- While using your ELIET machine, please carefully observe all safety instructions. Carefully read all instructions relating to the use of the machine. These instructions are in the interest of your own, personal safety.
- For your safety, ensure that the machine is always operating with properly sharpened cutters/ blades.
- Upon purchasing the machine, ask the dealer or a professional to explain how it works.
- Take note of all safety messages located on the machine in the form of text and pictograms. (see Section 7.1, page 13)
- Always apply the specific labor safety requirements in order to avoid any accidents.
- Under no circumstances should the original machine be modified without prior explicit, written permission from ELIET EUROPE S.A. (Belgium).
- Under no circumstances should a safety device be shunted, disassembled or deactivated/neutered.
- As shredding involves considerable physical effort, take regular breaks and make sure to eat and drink sufficiently.
- It is not recommended that persons with heart problems or balance disturbances operate the machine.
- Avoid inhaling the exhaust fumes from the machine. Exhaust gases contain toxic particles that could result in poisoning and even death. As such, the engine should never be started in an enclosed space.
- Once the engine has been started, there is a risk of wood chips being ejected.

7.3.2. Careful and sensible use

- This machine is designed solely for shredding branches, prunings, leaves and all other green garden debris. It should never be used for any other purposes than the ones indicated above.
- Never attempt to shred frozen branches.
- Ensure that you are concentrating on each of your actions as you use the machine. Do not let routine use of the machine dull your attention. Never act impulsively or reflexively.
- Despite the extensive safety features, do not take any reckless risks.
- Never allow any tools to enter the feeding hopper.
- Avoid allowing any other objects to enter the hopper (cords, stones, metal, plastic, textile, etc.)
- This model can shred branches with a maximum diameter of up to 100 mm. For your own safety, it is imperative that you never attempt to surpass this limit.
- The machine is not designed to be subjected to the stated maximum capacity (the maximum branch diameter) for long periods. As a guideline: no more than 10% of the waste to be shredded should have a branch diameter above 70 mm.
- Never use a step to feed garden waste into the feeding hopper.
- Do not use a garden fork or a shovel to feed green waste into the machine.
- Do not use your foot to push green waste into the infeed opening.
- Ensure that your working space has a minimum light intensity of 500 lux.
- Always remember to lock the wheels while the machine is operating to avoid the machine from moving unintentionally.
- For deontological reasons, ELIET distances itself completely from the shredding of animals and living organisms through the use of its machines.
- When working with the shredder, try to feed as much waste as possible into the right side of the infeed funnel, so that it stays as long as possible in the shredding chamber before being ejected.

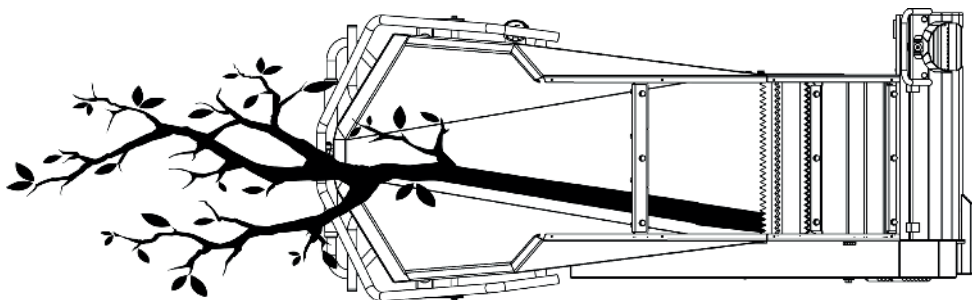

7.3.3. Responsibilities of the operator

- The person working with the machine should be familiar with all safety instructions. **The operator is fully liable when using the machine, in regard to themselves and others.**
- Operators are presumed to possess a certain level of maturity that permits them to make decisions based on common sense.
- Underage persons must not operate the machine. However, this does not apply to youths above the age of 16 who are learning to operate the machine under the supervision of an adult. This manual must be read before using the machine for the first time.
- Children below the age of 16 and animals must be kept away from the machine (10 m - 30 ft).

- Disabled persons may only operate the machine when under the supervision of an experienced operator.
- ELIET recommends that the machine should not be lent to others. However, if this is done, only lend it to persons who are familiar with the machine.

Always inform the other operator of the potential risks and make them read the manual before using the machine.

- Anyone who will work with this machine should be well-rested and in good physical condition. As soon as an operator begins to feel tired while working, they have to take a break. The machine is never to be operated after having consumed alcohol.
- Never operate the machine after consuming alcohol.



Warning: JUST ONE moment of inattention or carelessness can destroy a life.

7.3.4. Personal Protective Equipment (PPE)



For your information: The operator can reduce potential risks by wearing personal protective equipment.

- Working with this machine requires appropriate workwear: clothing that covers the entire body, sturdy work gloves and closed shoes with non-slip soles.
- Do not wear loose-fitting clothing (a scarf, for instance, should never be worn). If you have long hair, pull it back into a ponytail and wear a cap or a headband.
- Never wear a sweatshirt with drawstrings.
- To protect your eyes and ears, you must also wear safety goggles and hearing protectors.
- Shredding may result in dust production. If this dust irritates your lungs, ELIET recommends that you wear a dust mask that conforms to Directive 89/686/EC.



Caution: While wearing a hearing protector, more attention and vigilance are required, since any noises that may indicate a danger (such as screams, calls...) will be harder to hear. Eliet recommend not the use of a mobile, smartphone or MP3 player while working.

7.3.5. Danger zone

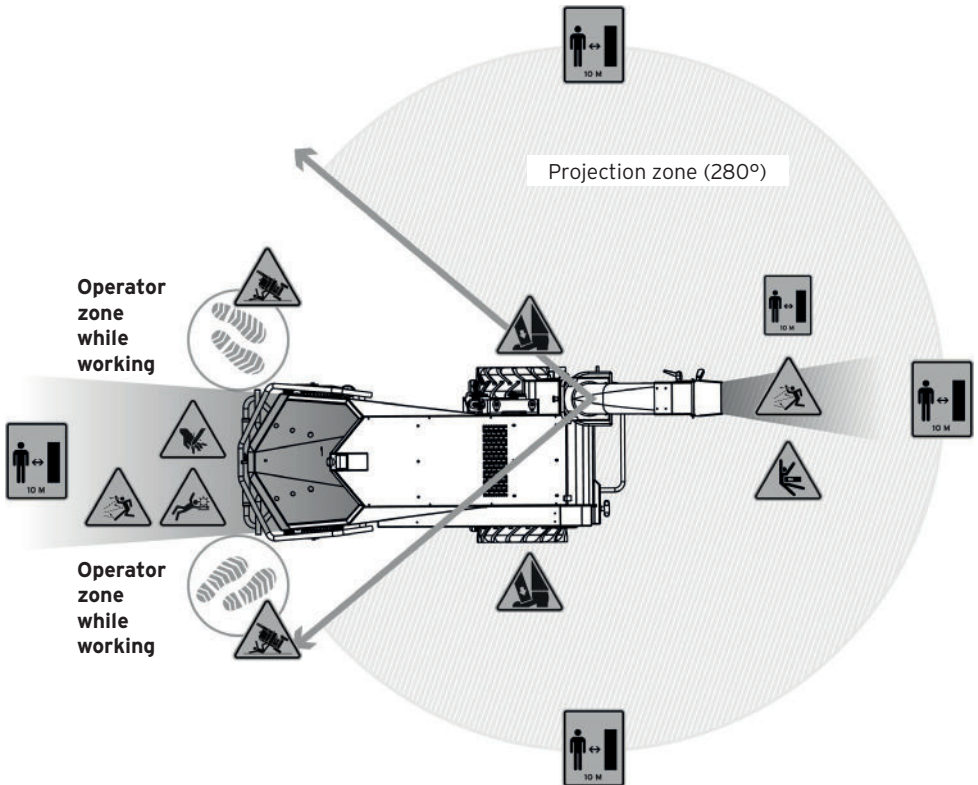

- While the machine is operating, make sure that nobody comes within 10 m - 30 ft of it. Do not take any risks: Turn off the engine immediately as soon as anyone enters the danger zone.
- When you walk away from the machine, the engine must be switched off. Always wait until the blades have come to a complete stop before carrying out any operations on the machine. Once the engine is running, focus all of your attention on operating the machine.

7.3.6. Regular maintenance



For your information: Regular maintenance is vital to ensuring your own security and a long service life from your machine.

- Periodic maintenance is essential. For this reason, strictly follow the maintenance schedule included in this instruction manual.(see Section 11.2, page 48)
- When certain parts must be replaced due to wear or damage, always consult your ELIET dealer and ask them for original ELIET replacement parts. This is important for your own safety (you will find an authorised ELIET dealer near you at www.eliyet.eu).
- Always make sure the engine is switched off and the battery cables disconnected before performing repairs or maintenance.



For your information: Please also carefully read the engine manual that is provided with the machine. This contains useful information for the proper use and maintenance of the engine.

7.3.7. Respect the environment

Use the machine in a way that respects the environment:

- Avoid to run the engine while you are not using it.
- Avoid spilling petrol (UK)/ gas (USA) while refuelling.
- Service the engine regularly in order to achieve optimum combustion.
- Sharpening and tightening the blades reduces the consumption of fuel.
- Avoid spilling sulphuric acid that is contained in the battery.
- When changing oil, the dirty oil should be set aside in order to be recycled.

8. Responsibilities of the dealer

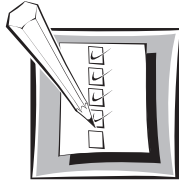

As an ELIET dealer, it is your obligation to instruct your customers on how to operate the machine and to point out the potential risks while using it. You are expected to carefully go over the maintenance points of the machine together with the new owner. Repeat these instructions until the new owner has fully understood them all. Special note: The following must be made explicitly clear to the customer:



For your information: We cannot insist enough on the importance of sufficiently informing your client of all potential risks.

AFTER THE FIRST 5 HOURS OF MACHINE USE, THE BLADE BOLTS MUST BE RETIGHTENED.

- Belt tension must also be readjusted after a running-in period of 10 hours.
- Each machine that leaves the factory contains a limited amount of oil and fuel. The dealer must check the levels of the oil and fuel, and top them up in accordance with the instructions in this manual (or in the engine manual).
- The dealer has to check the proper functioning of all safety features.
- The dealer will set the engine to 3,600 rpm.
- The dealer has to run the machine and let it run for a short period of time to confirm that everything is functioning properly.
- They will also check that the bolts securing the blades are tight.
- They will ensure that the cutters/blades are properly sharpened.
- As a final step, the dealer will make sure that the machine is correctly registered online, in order to avoid any potential, related warranty disputes. To this end, please read the warranty conditions included in this manual. (see Section 18, page 88)

9. Manual



9.1. Preliminary checks



Caution: Before you begin working, habit to check the following points:

Checklist

1. Make sure there is enough oil in the engine. (see Section 11.4.1, page 56)
2. Ensure that there is enough petrol (UK)/ gas (USA) in the tank. If necessary, top up the tank with petrol (UK)/ gas (USA). Keep in mind that average consumption is approximately 2.5l/h-5qt/h (see Section 9.2, page 27)
3. Check the condition of the air filter. (see Section 11.4.3, page 57)
4. Check the blades for wear and ensure that they are tightly fastened to the cutter supports. If they need to be sharpened, this must be done before you may proceed.
(see Section 11.5.2, page 62)
If you notice that the blades or blade shaft are cracked or broken, replace them immediately.
(see Section 11.5.3.2, page 67) As a further safety measure, retighten the blade bolts.
5. Check that the belt is still sufficiently taut. If this is not the case, retighten it. (see Section 11.5.4, page 69)
6. Check whether all safety features on the machine still operate correctly.
(see Section 7.2, page 18)

Once these items have been checked and approved, you can prepare the work area (see Section 9.3, page 28) and move the machine to the work site.

7. Monitoring tyre pressure:
 - Swivel wheels: 1.5 bar
 - Driving wheel: 1.5 barAdjust pressure if necessary.

9.2. Filling up with fuel



For your information: The fuel tank is equipped with a petrol (UK)/ gas (USA) level sensor. If the fuel level is too low, a red LED light will glow on the electrical box below the hopper.



For your information: The fuel tank has a capacity of 11 litres - 2.9 US gallons.

If there is not enough fuel in the machine, proceed with topping up the tank. ELIET recommends that you only use fresh petrol (UK)/ gas (USA) from a pump. (see Section 17.1, page 82) We recommend using E5 petrol (UK)/ gas (USA) or 95 RON petrol (UK)/ gas (USA). No other types of fuel are to be used in the machine. (Read the engine manual.)



Warning: Under certain conditions, petrol (UK)/ gas (USA) is highly flammable and extremely explosive. Fire and explosions caused by petrol (UK)/ gas (USA) can result in serious burns or damage to property.

- Never add fuel while the engine is running. Always allow a few minutes for the engine to cool off before topping up with fuel.
- Only use fresh petrol (UK)/ gas (USA).
- Never add oil to petrol (UK)/ gas (USA).
- Because of the short shelf life of petrol (UK)/ gas (USA), ELIET recommends that you buy it in small quantities.
- Store fuel in an approved container. Keep this container out of reach of children.
- Store fuel in a well-ventilated area away from open flames, sparks and heat sources.
- Never top up fuel in the location where work is to be performed. Always keep a distance of at least 10 m - 30 ft from that location. This will help prevent any risk of fire.
- Clean the area around the fuel tank filler cap **(1)** before unscrewing it. Never fill the tank to the point of overflowing. Fill the tank to within 50 mm - 2" of the top. Do not fill it up all the way to the opening.
- To do so, always use a clean funnel/pouring spout with a filter to prevent the introduction of dirt in the tank. Your ELIET dealer will provide you with an appropriate funnel.

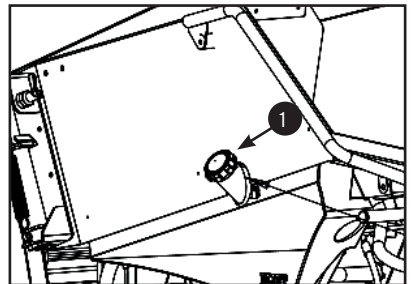

- Refit the fuel filler cap as quickly as possible.
- Be careful not to spill petrol (UK)/ gas (USA) onto your clothing. If you should do so, change out of these clothes immediately.



Caution: Never top up the fuel tank in the vicinity of smokers or naked flames.

- In the event that fuel is swallowed or gets into your eyes, obtain medical attention immediately.

9.3. Preparing the work area

- First clear the area where the machine will be used. In addition, the paths leading to the working area, to prevent the operator from tripping over any obstacles. This is another measure the operator must take for their own safety.
- Position the machine in such a way that the chips ejected from the discharge blow chute do not cause personal injury or material damage.
- Always engage the parking brake once the machine has been placed in the work area. Place something behind the wheels or tracks to prevent any unintended movements by the machine due to gravity and/or vibrations.
- The machine must never be used on sloped surfaces (whether lateral, uphill or downhill).
- Make sure to sort the material to be shredded beforehand. This provides the operator the opportunity to ensure that no foreign objects will enter the machine along with the material.
- Foreign objects are defined as: any non-green object (such as metal, stones, plastic, PVC, cords, etc.) or green material with a diameter in excess of the stated capacity. Not only can these objects cause serious damage to your machine, but they can also be ejected from the machine and cause serious harm.
- Always position the machine in a way so that the wind will blow the dust that is produced away from the engine and from the operator.
- **Option:** For better control over the ejection of wood chips, a reinforced canvas attachment for the blow chute is available, which directs the wood chips below the chute. For example, they can be ejected into a wheelbarrow, trailer, big bag, etc. Order number: MA 032 001 003

9.4. Starting and turning off the engine



Warning: Never start the machine if the engine cooling fins are not clean or free of debris to protect the engine from overheating.



For your information: Also read the engine manual that has been provided.



Warning: Under no circumstances should the engine ever be started in an enclosed space for more than 30 consecutive seconds. Exhaust gases contain toxic substances and may lead to poisoning or suffocation.



Caution: Ensure that no unauthorised persons are within a radius of 10 m - 30 ft around the machine before starting the engine.



Caution: Ensure that the blow chute has been placed into the working position and that the deflector has been lowered before starting the engine.



Warning: The blades begin moving as soon as the engine is started. If there are any wood chips still remaining in the shredder or the turbine, they will be projected from the machine. Ensure that no one is present in the projection zone.

Before starting the engine, check that there is sufficient oil and fuel in the engine. If necessary, read the following sections:

- See "11.4.1. Checking engine oil level + refilling", page 56.
- See "9.2. Filling up with fuel", page 27.



Warning: Before starting up the machine, protect your ears with hearing protectors and your eyes with the safety goggles.

- Ensure that the shredding chamber and turbo are empty, in order to avoid overloading the starter mechanism.
- Ensure that the feeding hopper is empty (no green waste, no tools, etc.).
- Set the deflector to the "working position".

Subaru engine:

1. Open the fuel valve **(1)** on the engine.
2. Set the choke **(2)** to "closed".
3. Move the throttle lever **(3)** up to the maximum position, towards the image of the rabbit.
4. Turn the ignition key **(4)** to the right, and release the key as soon as the engine has started.

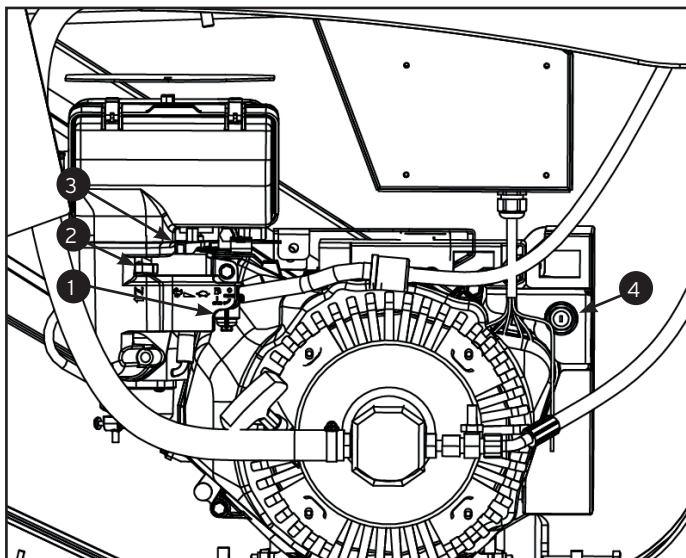
**Vanguard engine:**

For your information:
The throttle lever allows the operator to adjust the RPM, open the fuel shut off valve and stop the engine.

1. Push the throttle lever **(1)** to the maximum position (rabbit image).
2. Set the choke **(2)** to "closed".
3. Turn the ignition key **(3)** to the right, and release as soon as the engine has started.

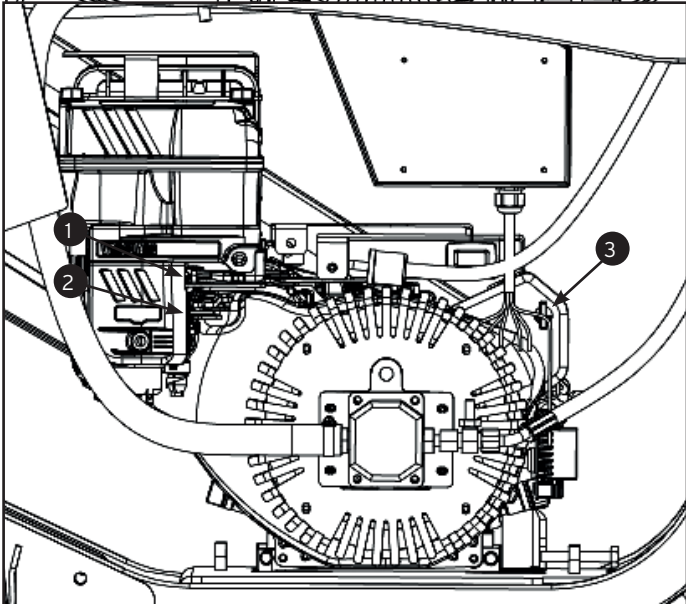

Once the engine has been running for a few seconds (+/- 5 seconds maximum), set the choke directly to the "open" position. This is an important step, since it will avoid overflowing the engine with petrol (UK)/ gas (USA). Otherwise, the engine will slow down, start emitting thick smoke and finally cut out. If this should happen, restart the engine without using the starter.

If you are no longer able to start the engine, this is likely due to a dirty spark plug. In that case, you will either need to clean it or replace it.

Procedure for shutting off the engine:



Caution: Only shut off the engine once the shredder, the shredding chamber and the turbine are empty. You will know when this is when no more wood chips are being ejected from the blow chute. The blade shaft will continue to turn due to inertia after the engine has been shut off. Wait a few seconds to ensure that it has come to a complete stop before conducting any interventions on the machine.

- Wait for the feeding hopper to be completely empty, +/- ensure that no more wood chips are being ejected from the blow chute.
- Turn off the feeding roller to avoid any further material from being fed into the machine.
- Wait a few moments to ensure that all waste has been shredded.
- Slowly reduce the engine speed, and pull the throttle lever back to the image of the turtle.
- Afterwards, for the:
 - **Subaru engine:** Turn the ignition key to the "O" position.
 - **Vanguard engine:** Set the throttle to the lowest position (O).

9.5. Moving the machine

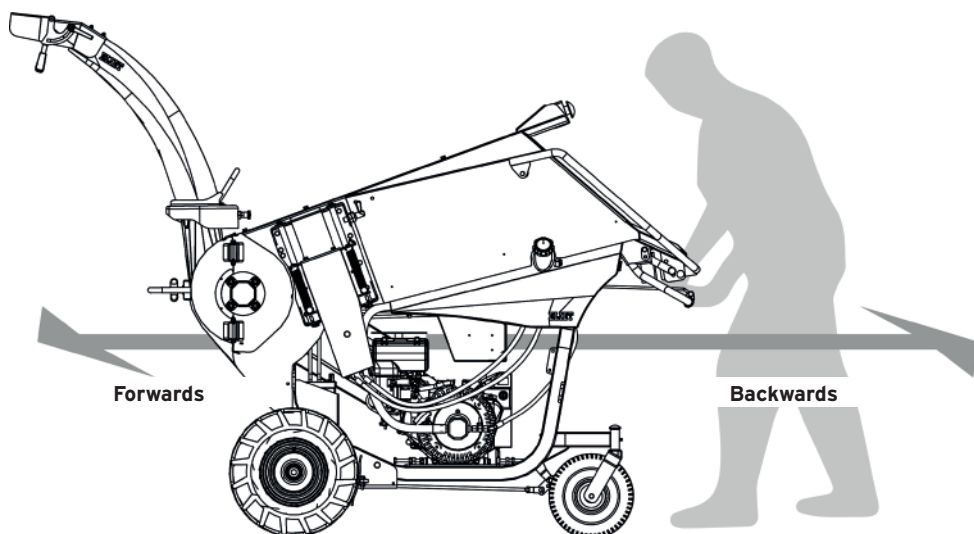



Caution: Only move the machine once the deflector has been lowered to the maximum position to avoid the risk of any remaining shredded material being ejected. The machine is equipped with a freewheel that allows it to be pushed by hand when the engine has been shut off.



Caution: When moving the machine, ensure that any bystanders are at a minimum distance of 10 m - 30 ft. If anyone begins to move towards you, stop moving immediately.

TIP:

You should first try to become familiar with how a self-propelled machine moves by experimenting with it in a quiet, open area without any bystanders.

A. If you have a self-propelled machine (ZR type)

- Start the engine. (see Section 9.4, page 29)
- Reduce engine speed. (2,500 rpms)



Caution: Once the engine has been turned on, there is an imminent risk of ejection. If there are any wood chips remaining inside the machine, they could be blown out. This is why it is important for you to always wear safety goggles.

• Moving the machine:

- Turning-twisting the control handle forwards will cause the machine to move forwards. The more you twist the control handle forwards, the faster the machine will move. This also applies to the opposite direction: Turning the control handle in the opposite direction will cause the machine to move backwards. The more you turn-twist the handle the faster the machine will move. Ensure that the area in which the machine will move is free from anything that can be damaged by projectiles.
- To make a turn with the machine push the handle (left or right) while simultaneously twisting the handle to move the machine.
- The intensity with which you push the handle to the side will determine the turning radius.
- In order to manoeuvre between obstacles, you will need to reduce the speed of the machine (decrease RPM) to avoid losing control.

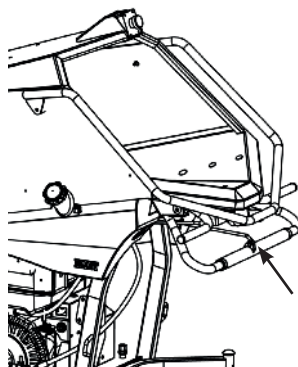

A. If you have the Cross Country version (version with tracks):

- Start the engine. (see Section 9.4, page 29)
- Reduce engine speed. (2,500 rpms)
- To move the machine, perform the following steps: The control handle consists of two separate handles: The left-side handle controls the left track, and the right-side handle controls the right track.

- To move the machine forwards in a straight line (forwards or backwards): turn-twist both control handles at the same time. Moving both control handles forwards will cause the machine to move forwards; turning-twisting them backwards will cause the machine to move backwards.



Caution: If you do not turn-twist both control handles by the same amount, the machine will not move in a straight line.

- To turn to the right: the machine will turn to the right if you twist more the left handle **(1)**. The greater the difference between the control handles, the more the machine will turn.
- To turn to the left: the machine will turn to the left if you twist more the right handle **(2)**. The greater the difference between the controls the more the machine will turn.
- To turn the machine on the spot: bring throttle lever to the minimum (tortoise) and turn-twist each handle in opposite directions. This may cause the machine to change directions very suddenly.

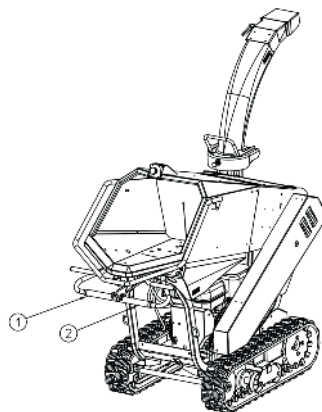

MIND YOUR FEET!

The operator must always stay alert and move the control handles carefully.

If you feel like you are losing control of the machine, immediately let go of the two handles and move away from the machine.



Warning: If you fall, immediately let go of the handles to avoid moving them unintentionally and incurring the risk of the machine falling onto you.



Warning: The machine can change direction suddenly. Ensure that you have enough space to manoeuvre before moving into a tight space. You can always pull back on the throttle lever to decrease the engine speed.

TIP:

You should first try to become familiar with how a self-propelled machine moves by experimenting with it in a quiet, open area without any bystanders.



Warning: The more you twist the handle the faster the machine will move. The more you increase the engine RPM the faster the machine will move.

A. Going down a slope:

Always point the hopper of the machine towards the bottom of the slope so that it descends in reverse.



Warning: On steeper slopes, the machine may pick up speed on its own due to its own weight. This may result in losing control over the speed of the machine. As soon as you notice this happening, quickly turn the handle in the opposite direction to slow down the machine and regain control over its speed.

Always remain alert and focused on what you are doing! Ensure that there is enough free space at the bottom of the slope (at least 3x the length of the machine).

B. How to move the machine in the event of engine failure:

The wheels/tracks are driven by the oil pressure created by the hydraulic pump. This pump is powered by the engine. If the engine is not running, the hydraulic power will not function either. External force can be used to push or pull the machine forwards or backwards. However, this requires the circulation of oil in the wheel motors. To make this happen, turn the driving handle in the same direction in which you wish to move the machine.

In the Cross Country version with tracks, you will encounter greater resistance. The pulling or pushing force will need to be significant in order to move the machine. As such: try first to repair the engine on site to move it properly instead of hauling it away.

9.6. Working with the machine

9.6.1. Before you start working

- Wear proper clothing, protective gloves and other accessories as instructed in this manual. See "7.3. Safety precautions", page 20.
- A good gardener should plan out their work and be well-organised. This will enable you to have perfect control over your work and to avoid accidents.
- The waste to be shredded should be systematically sorted before commencing the work: big branches, small branches, leaves and any damp objects. Ensure that the material does not contain any foreign objects.
- Do not use the machine in an enclosed or poorly-ventilated space. Otherwise, there is a serious risk of being poisoned by the toxic exhaust fumes from the engine.
- Always shred at full throttle.
- The parking brake should be set as soon as the machine is in the work area.



Warning: Before you begin shredding, ensure that the blow chute is set to the vertical position. Point the blow chute and the deflectors in the desired direction.

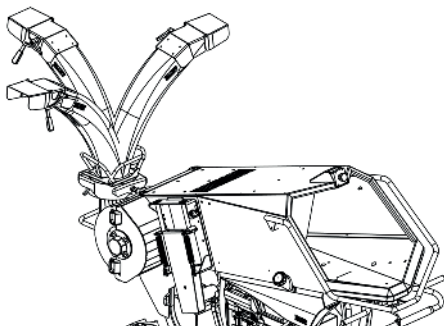

9.6.2. Turning and positioning the blow chute and deflector

- To position the blow chute, you will need to release the lever **(1)**, hold the handle on the blow chute **(2)** and turn it to the desired position. Once the blow chute has been set to the desired position, the lever **(1)** can be retightened.
- To set the deflector in the desired position, use the handle **(3)** to position the deflector and then retighten the handle **(4)** to keep it in that position.

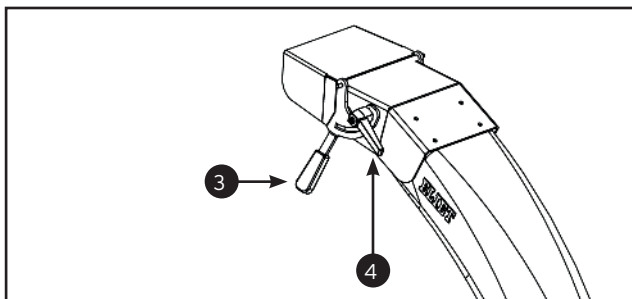
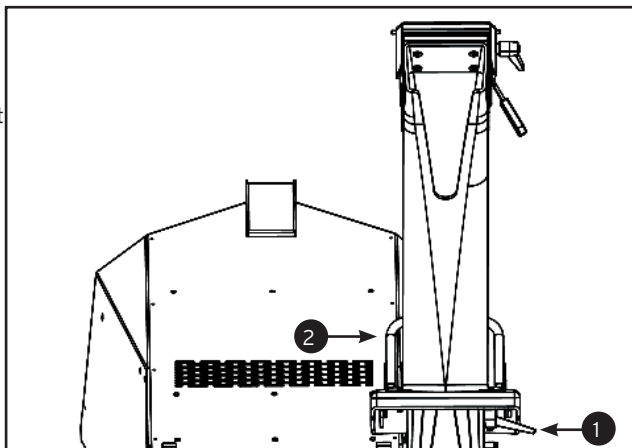

9.6.3. While working



Caution: Always wear personal protective equipment. (Safety goggles, gloves, hearing protectors, safety footwear, etc.)

- Be very attentive while working. While operating the machine, you must focus all of your attention on it.
- Start the engine. (see Section 9.4, page 29)
- Allow the machine to run empty for at least 5 minutes so that it heats up.



For your information: When shredding at temperatures around freezing, you will have to ensure that you are shredding branches with a maximum diameter of 50 mm - 2".



For your information: Always shred at full throttle. This will ensure optimal performance.

9.6.4. Operating the feed roller

In order to simplify operating the feed roller, we have opted for a clear and comprehensible system that requires you to move the handle, as depicted below.

- Pulling on the handle (see the image below) will cause the feed roller to start moving, drawing the material to be shredded into the feeding hopper at a constant speed. If you push the handle forward once, the feed roller will stop. If you push on the handle a second time, the feed roller will move in the opposite direction and move the material out of the feed hopper.
- The feeding position (IN) is a fixed position.
- The stop position of the feed roller (STOP) is also a fixed position.
- The backflow position (OUT) is a variable position. The handle will automatically return to the stop position. In order to continue the backflow of material, you will need to continuously push on the handle.

- There are two handles. They are both connected, which enables you to work on either side of the shredder and to avoid any risks from projectiles by standing in front of the hopper.

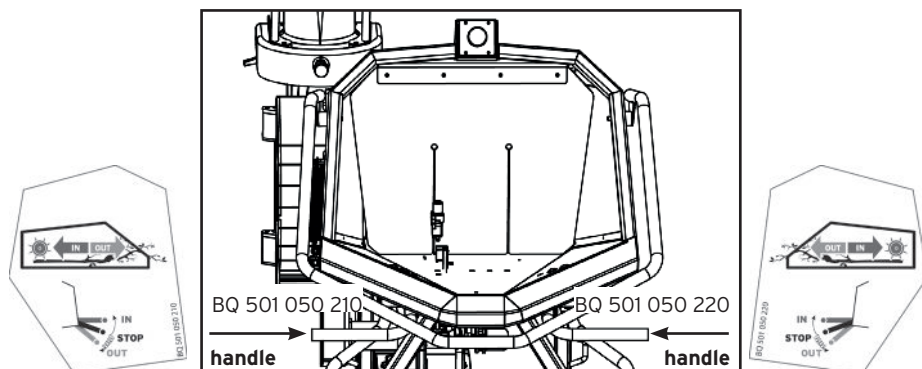

- You should preferably stand to the side of the feeding hopper when putting green waste into it. This will keep you out of the path of any wood chips that might still be ejected past the anti-projectile shield.
- Feed the green waste into the hopper and guide it towards the anti-projectile shield. In the case of loose waste (leaves, etc.), use a branch or the remaining waste to be shredded to push the material towards the shield. (DO NOT USE a shovel or a garden fork).
- In the case of branches, it is recommended to feed in the thickest part of the branch first.
- Never use a footstep to feed green waste into the hopper.
- In order to ensure more intense shredding and smaller wood chips, it is recommended to feed the waste into the hopper along the right side of the infed hopper. This will ensure that the chips travel through the entire shredding chamber before they are ejected. The result is a finer cut.

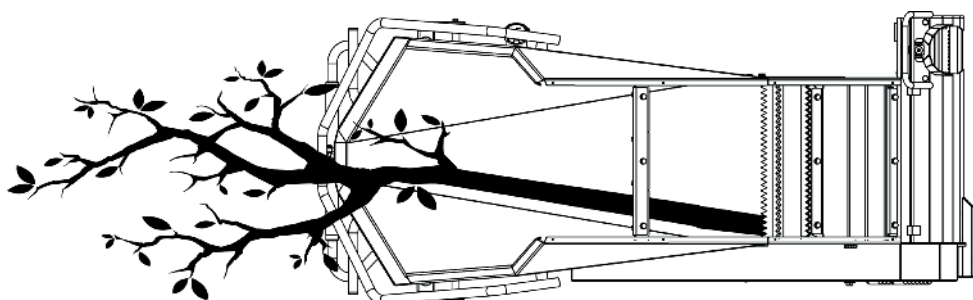

- When feeding green waste into the machine, the operator should never, under any circumstances, place their hands beyond the anti-projection shield.
- Never push jammed waste into the hopper with your foot.
- If the emergency safety bar has been pushed, the feed roller will stop. It cannot be restarted until the bar has first been reset below the hopper.
- This also applies to the emergency stop button: Once it has been pushed, the feed roller can no longer be controlled without first having reset the emergency stop button by turning it and pulling it up at the same time.



Caution: Do not lean over the feeding hopper to push material into it, in order to prevent yourself from EVER placing your hands into the machine beyond the anti-projectile shield.

- You will obtain quicker results by reducing the amount of material that you feed into the machine.
- In the case of branches, it is recommended to feed in the thickest part of the branch first.
- If possible, wet, soft and/or leafy pruning waste should be alternated as much as possible with woody material. The idea is to prevent the wet stuff from clogging the shredding chamber. If wood chips are no longer being ejected, this indicates a blockage.
- Immediately push on the feed roller and hold it in the backflow position (OUT) to force the wood chips in the shredding chamber to be ejected into the feeding hopper.
- Then turn off the machine. Open the shredding chamber and remove the wood chips.



Caution: Always wear protective gloves. You risk cutting your hands on the blades.

- Check the blow chute and unlog it completely if necessary.



Caution: Thick branches that have been sawn at both ends must be fed in from the left side of the hopper so that they are guided in by the side of the hopper. Make sure that branches do not turn diagonally to the in-feed direction, as this can block the machine.

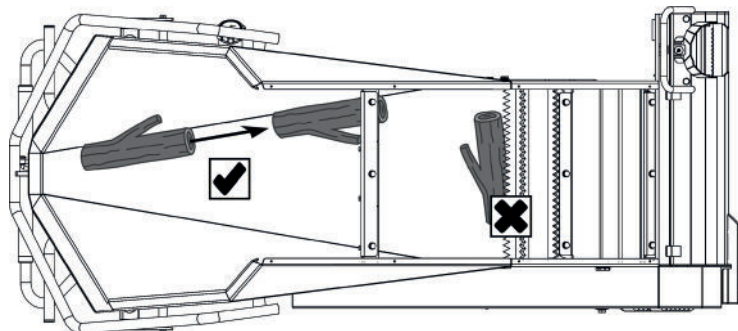

To stop the feed roller:

- push on the feeding handle. (see Section 9.6.4, page 36)
- push on the emergency safety handle.
- push on the emergency stop button.

The rotation direction of the feed roller can be reversed by pushing on the control handle. This is very useful if ever a piece of wood becomes lodged under the roller.

- **With speed regulation:** If you have selected this option (rotary knob beneath the feeding hopper, to the left), you can regulate the speed of the feed roller according to the material to be shredded. By adjusting the knob (in the range of 1 to 10), you can obtain maximum performance. (Optional equipment)
- **ABM system (anti-block motor):** To keep the shredder unit from staling and to ensure that the machine functions autonomously, you have chosen an ABM system (anti-block motor). When the engine RPM drops below 3000 the feeder will automatically stop feeding. once the RPM is back above 3000 the feeder will start-feed again automatically. When the engine revolution speed has been re-established to above 3,000 rpm, the feed roller will restart automatically.

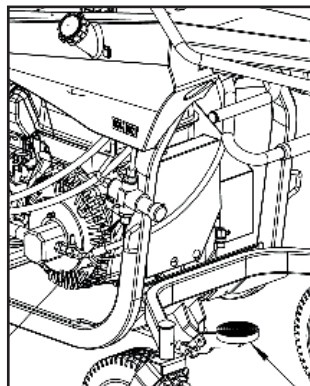

If any unusual sounds are heard coming from the shredding chamber, immediately turn off the machine to remove the obstruction:

- Stop the feed roller by pushing the emergency safety bar.
- Pull the throttle lever back to the minimum position.
- Stop the engine using the ignition key.



Caution: Make sure the blades have come to a complete standstill before carrying out any operation on the machine. As an extra **safety measure, remove the starter key.**

- Open the maintenance hatch in order to access the blade shaft and the discharge system. (see Section 11.3.4, page 53)
- Check the Turbo fan for damage.
- Check the blades and the blade holders for damage.
- In the event of damage, make the necessary repair before working again.

If you notice a foreign object in the green waste in the feeding hopper, perform the following steps:

- Push on the feed roller handle as far as it will go to push the material out of the machine.
- Stop the engine.
- You may now safely reach into the feeding hopper to remove the foreign object that you found amongst the green waste.
- Remove any foreign objects.

9.7. After working

9.7.1. Cleaning the machine

It is strongly recommended that you clean the machine after each use according to the instructions in the following section. (see Section 11.2.2, page 50)

Failure to regularly clean your machine will:

- Lead to premature wear of the bearings, gaskets and drive belts
- Increase the risk of fire
- Decrease the cooling efficiency of the engine
- Cause fractures or cracks to become undetectable
- Have a detrimental effect on the paint coating and safety stickers.



Warning: A machine that is no longer in optimal working condition may compromise the safety of the operator.



Caution: Wear suitable clothing when cleaning. You must always wear protective gloves.

- Empty the shredding chamber after each use.
- Remove any leftover shredded material and green waste from the feeding hopper.
- Remove any leftover shredded material and wood dust that has accumulated in the cavities of the machine.
- Remove any leftover shredded material that has become stuck to the feed roller's shaft guidance system.
- Use a dry cloth, a soft brush, etc. for cleaning. To remove grease and lubricants, use penetrating oil containing molybdenum disulphide. This spray lubricates and also dissolves rust.
- It is also practical to keep compressed air at hand. It can be used to easily clean various components.
- Pay special attention to cleaning the engine. The cooling fins and air inlet in particular must be thoroughly cleaned in order to guarantee optimal engine cooling.
- Make sure that no leftover shredded material is present on the exhaust system, since it could catch fire or continue to smoulder after the machine has been turned off.
- Never clean the machine using a high pressure washer. Do not put too much cleaning pressure on bearings, electrical components or filler caps. If you use water to clean the machine, do not allow too much water to infiltrate bearings, electrical components or filler caps. Water can penetrate the electrical panel and cause short-circuits. Moisture can also cause corrosion and lead to faults in the electrical system or premature wear of the machine.
- Water is the main cause of rust formation and must be avoided at all times.
- Lubricant is washed away during cleaning. As such, you should also plan to lubricate the machine again after cleaning it.
- The engine manufacturer does not recommend water cleaning.

9.8. Lifting the machine (ZR and Cross Country)

The machine can be optionally fitted with two hoisting rings that can be used to hoist it using a crane or a lifting arm, in order to store it in physically inaccessible locations. For certain maintenance tasks, the machine has to be placed or lifted onto a workbench. A winch can be used in this case.



Warning: No person should ever be lifted with the machine.



Warning: While lifting the machine, ensure that the operator is not attached to it. Wear tight-fitting work clothes. In addition, when lowering the machine, mind the placement of your feet. Maintain sufficient distance from the machine, and wear reinforced work footwear.

- Always set the blow chute to the working position. Prevent the blow chute from hindering the movement of lifting cables or straps. Turn and lock the chute into the position in which it is pointing forwards and along the axis of the hopper.

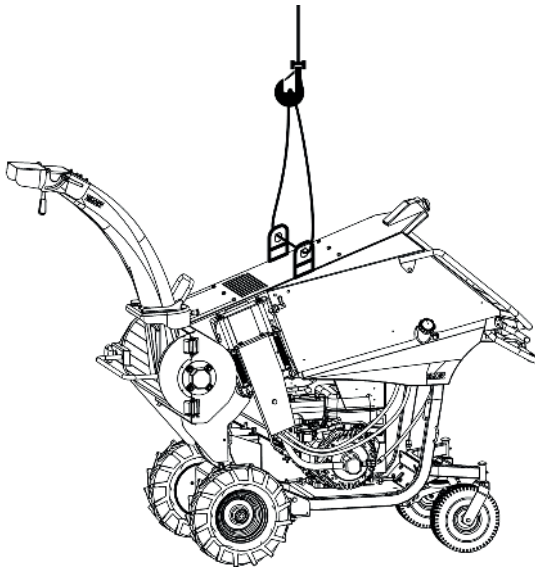

- Use lanyards to secure the machine in place. Ensure that the cables, chains or straps used for hoisting the machine are always suspended vertically above the central line of the hoisting rings. This will prevent the machine from swinging during the lifting process.



Warning: The machine must never be lifted using only one hoisting ring.

To ensure that the hoisting straps have been attached correctly, please see the below examples.

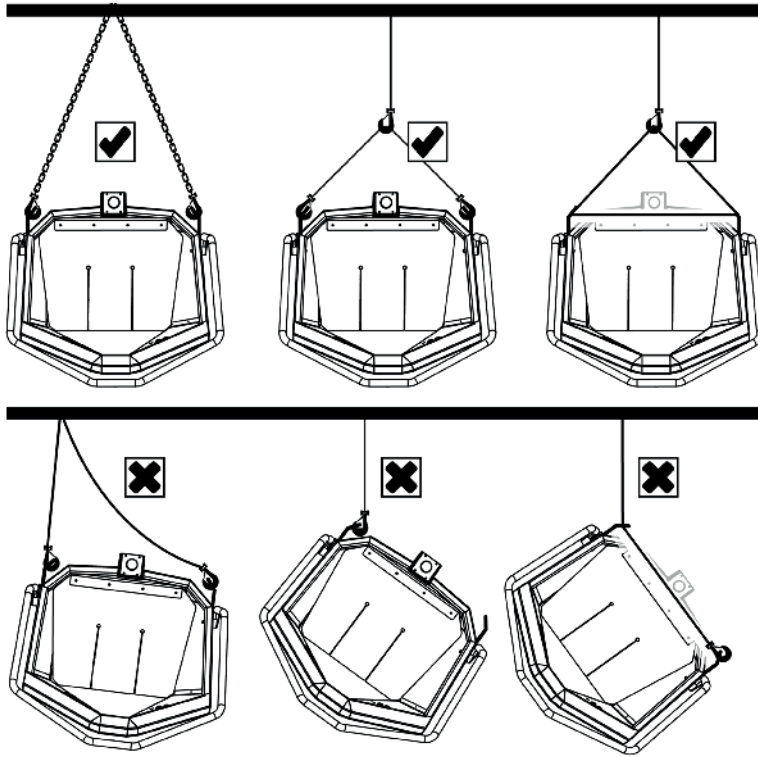

- Before lifting the machine, the engine must always be turned off.
- Ensure that the four M10 bolts that attach the hoisting rings to the machine are not loose (2 x 17 mm wrench).
- Insert the hook into the hoisting ring. Choose a hook that is large enough to securely close after it has been inserted through the hoisting ring. Ensure that the hoisting strap to be used is not damaged. Slide the hoisting strap through the hoisting ring. Avoid twisting the hoisting strap.



Caution: Check the machine's identification label to find out its weight. Ensure that the hoist to be used can handle the weight of the machine. Only hoisting elements (chains, ropes, straps...) that have a recent certificate of inspection are to be used.

- The positioning of the hoisting rings is such that the machine will remain level as it is being lifted. Additional weight should never be added to the machine, either by placing objects into the hopper or attaching them to the machine.



Caution: Keep all assistants at a safe distance of 10 metres - 30 ft.

- Use a slow lifting speed to minimise the impact of inertial force.
- Do not lift the machine higher than necessary.



Caution: You must never stand below the machine as it is being lifted.

- Do not leave the machine suspended in the air longer than is necessary.
- Only place the machine on a surface that can support its weight.

10. Transporting the machine

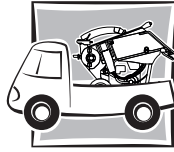

- Make sure the machine is properly secured to the vehicle during transport. Use the 4 eyelets along the side of the frame (2 each side) to attach the straps or ropes.

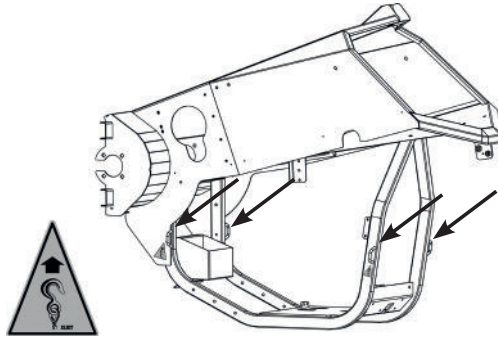

- It is very important that the infeed opening is completely free of branches and material.
- Before loading the Prof 6 onto a trailer or into a van, the blow chute may be lowered to accommodate the vehicle's height. Use the following procedure: See "11.3.5. Setting the blow chute to the working or lowered position", page 54.
- If you are stepping up onto a trailer, ensure that it is securely attached to the leading vehicle.
- Use slip-resistant ramps to load the machine into a van or trailer. Ensure that they have been properly attached to the vehicle or the trailer, and that the vehicle's hand brake has also been set.
- The maximum degree of lateral slope authorised for the shredder is 10%.
- Under no circumstances should the angle of the ramps going up or down exceed 20%.
- When loading and unloading the machine, turn on the engine, and remain careful and wariness, so that the machine does not tip over and cause an accident.
- When coming down a ramp, descend backwards while facing the machine. See "9.5. Moving the machine", page 31.
- If gravity causes the machine to descend more quickly down the slope than is desired, quickly move the control handle in the other direction. This activates the hydraulic brake on the machine.

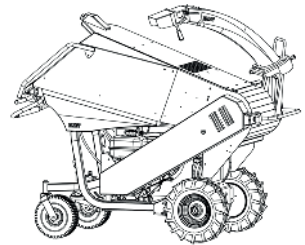

- Never leave the engine running for more than 30 seconds in a tight or enclosed space, for example, inside a van, etc. Make sure that the work area has been prepared in advance in order to set the machine into position quickly.
- Make sure that the machine is properly secured to the vehicle during transport. Use the 4 eyelets of the frame (2 each side) to attach ropes or straps. Four eyelets are provided in order to attach hooks.
- Always engage the parking brake on the machine.
- Do not forget that the machine has a high centre of gravity. Use straps to secure both sides of the machine to the vehicle. This ensures that the machine will not topple over when the vehicle goes around a bend.
- Do not overload the vehicle. Read "15. Equipment specifications", page 80 for the exact weight of the shredder.



Warning: Under no circumstances should the machine be used if the blow chute is still in the transport position. The wood chips could be blown out in the direction of the operator and cause serious injury.

11. Maintenance



11.1. General

ELIET recommends that you bring your machine to an authorised ELIET dealer once a year so that it can undergo a complete maintenance inspection (you can find an authorised ELIET dealer in your area at www.eliyet.eu). Your ELIET dealer is always at your service for your maintenance needs and to advise you. They will have original ELIET parts and lubricants in stock in their store. Their staff can always obtain advice and service from the help desk at ELIET, in order to provide you with impeccable after-sales service.



Attention: Only use original ELIET replacement parts for repairs. These parts are manufactured according to the same standards and quality as the original machine parts. You can always consult a list of original replacement parts and their reference numbers at www.eliyet.eu.

Perform maintenance in a room intended for this purpose. This room must be:

- Spacious
- Dust-free
- Easily accessible
- Tidy
- Well lit
- Quiet

These conditions are important to the proper execution of your maintenance tasks.



Caution: Improper maintenance may subsequently compromise the safety of the operator.

**Caution:**

Particular attention must also be paid to these maintenance tasks. Any elements that may distract the operator must be eliminated:

- Avoid unnecessary cluttering in the work area
- Do not wear headphones to listen to music or the radio
- Avoid other external distractions that may attract your attention, such as screens, etc.
- Turn off your smartphone, in order to avoid being distracted by messages or calls.

The engine must always be turned off and the battery terminals must be disconnected before any maintenance work on the machine is conducted. (Disconnect the + terminal). Never leave the battery disconnected for more than 1 day. If it is disconnected for too long, some components will have to be reprogrammed.

When performing maintenance, always wear gloves, and also safety goggles for some operations. These have been provided with your machine.



Caution: Avoid causing short-circuits with the tool you use to reconnect the + terminal.

TIP:

The maintenance work described below can essentially be performed by any person who possesses the requisite technical knowledge. However, ELIET recommends that the machine be taken once a year to your dealer to be serviced completely. Your ELIET dealer is always there to service your machine and advise you. They also have a stock of original ELIET replacement parts and recommended lubricants. Their staff can always obtain advice and service from ELIET, in order to provide you with impeccable after-sales service.

11.2. Maintenance schedule

On the right side of the engine above the ignition key, you will find the engine operation hours displayed.

	Shredder	Engine
/day	"11.2.2. Daily maintenance", page 50	
5	Lubrication "11.5.8.13.2. Grease fittings for large doses", page 73	Cleaning the air filter "11.4.3. Cleaning the air filter", page 57
10	Routine inspection of the blades "11.5.1. Routine inspection of the blades", page 61	
25	Lubrication "11.5.8.13.1. Grease fittings for small doses", page 73	Changing the engine oil "11.4.2. Changing the engine oil", page 57
50	Checking belt tension "11.5.4. Checking the tension of the drive belt", page 69	
100	Turning blades "11.5.3. Turning or replacing the blades", page 64	
200	Changing blades "11.5.3. Turning or replacing the blades", page 64 Replacing belts "11.5.5. Checking the alignment of the pulleys / Replacing the belt", page 69	Replacing the air filter "11.4.4. Replacing the air filter", page 58
400		Changing the hydraulic fluid filter "11.4.7. Changing the hydraulic fluid filter", page 59 Refilling the hydraulic fluid "11.4.6. Refilling the hydraulic fluid", page 58

11.2.1. Special maintenance

a. Special maintenance of the blades

After inserting the blades into the shaft, they will need a short running-in period. This could lead to a loosening of the bolts. The blades could even come loose over time and become wedged between the blade discs if they are not checked regularly. This could cause irreparable damage to the blade shaft. This must be prevented by scheduling extra maintenance after the brief running-in period.

When:

- Within the first 5 operating hours after starting up the new machine.
- Within the first 5 hours after turning the blades.
- Within the first 5 hours after replacing the blades.

What:

- Check all blade bolts for correct torque and adjust if necessary.
(see Section 17.2, page 83)



Warning: Failure to perform this special maintenance will compromise the safety of operators and bystanders, and can cause serious damage to the machine.

b. Special maintenance of the drive belt

The belt that transfers power from the engine to the blade shaft is long. During the running-in period, the belt will stretch naturally. This stretching will reduce the tension of the belt. Using the machine when the belt tension is too low will cause the belt to slip, twist or come off the pulleys. These three possibilities will have a detrimental effect on a new belt.

When:

- Within the first 10 operating hours after starting up the new machine.
- Within the first 10 hours after changing a belt.

What:

- Ensure correct belt tension. (see Section 11.5.4, page 69)

c. Special maintenance related to replacing the engine oil

All wear-and-tear particles and manufacturing dirt that is created or is still present in the engine will be captured by the oil filter. Fine particles that have not been captured by the oil filter will be rinsed away by this special maintenance.

When:

- Within the first 5 operating hours after starting up the new machine.

What:

- Change the engine oil. (see Section 11.4.2, page 57)

11.2.2. Daily maintenance



Caution: Before performing any maintenance, stop the engine and remove the ignition key. Wear appropriate clothing.

- Check for signs of leakage.
- Open the shredding chamber. (see Section 11.3.4, page 53)
- Clean the machine. (see Section 9.7.1, page 40)
- Check the condition of the blades and sharpen them if necessary; also check that the blades are securely fastened. (see Section 11.5.1, page 61)
- Check the machine for signs of abnormal wear or cracks.
- Check the impeller for signs of abnormal wear or cracks.
- Check the bolts (blades, wheels, bearings, engine, etc.).
- Check the engine oil level. (see Section 11.4.1, page 56)

11.2.3. Maintenance after 5 hours of use



Caution: Before performing any maintenance, stop the engine and remove the ignition key. Wear appropriate clothing.

- Conduct daily maintenance. (see Section 11.2.2, page 50)
- Clean the air cleaner. (see Section 11.4.3, page 57)
- Check torque on 24 blade bolts

11.2.4. Maintenance after 10 hours of use



Caution: Before performing any maintenance, stop the engine and remove the ignition key. Wear appropriate clothing.

- Conduct daily maintenance. (see Section 11.2.2, page 50)
- Check the condition of the blades and sharpen them if necessary (see Section 11.5.1, page 61)
- Check belt tension

11.2.5. Maintenance after 25 hours of use



Caution: Before performing any maintenance, stop the engine and remove the ignition key. Wear appropriate clothing.

- Conduct daily maintenance. (see Section 11.2.2, page 50)
- Change the engine oil. (see Section 11.4.2, page 57)
- Grease various grease fittings. (see Section 11.5.8, page 72)

11.2.6. Maintenance after 50 hours of use



Caution: Before performing any maintenance, stop the engine and remove the ignition key. Wear appropriate clothing.

- Conduct daily maintenance. (see Section 11.2.2, page 50)
- Ensure correct belt tension. (see Section 11.5.4, page 69)
- Check if the blades are still sharp (see Section 11.5.3, page 64)
- Check the tension of the chain and adjust it if necessary. (see Section 11.5.6, page 70)
- Conduct a general and complete lubrication of the machine. (see Section 11.5.8, page 72)

11.2.7. Maintenance after 100 hours of use (or every six months)



Caution: Before performing any maintenance, stop the engine and remove the ignition key. Wear appropriate clothing.

- Conduct daily maintenance. (see Section 11.2.2, page 50)
- Conduct maintenance after 50 hours. (see Section 11.2.6, page 51)
- Turn the blades. (see Section 11.5.3, page 64)
- Replace the oil filter. (see Section 11.4.7, page 59)

11.2.8. Maintenance after 200 hours of use (or annually)



Caution: Before performing any maintenance, stop the engine and remove the ignition key. Wear appropriate clothing.

- Conduct maintenance after 100 hours. (see Section 11.2.7, page 51)
- Clean the air cleaner. (see Section 11.4.3, page 57)
- Turn the RESIST™ blades. (see Section 11.5.3, page 64)
- Replace the air filter. (see Section 11.4.4, page 58)
- Replace the fuel filter. (see Section 11.4.5, page 58)
- Change the spark plugs (read the engine manual).
- Check the tracks. (see Section 11.5.7, page 71)

11.2.9. Maintenance after 400 hours of use



Caution: Before performing any maintenance, stop the engine and remove the ignition key. Wear appropriate clothing.

- Change the hydraulic fluid. (see Section 11.4.6, page 58)
- Replace the hydraulic fluid filter. (see Section 11.4.7, page 59)

After performing maintenance or repairs, make sure that you correctly refit ALL guards.

11.3. Miscellaneous interventions

Warning: For your own safety: After you have completed your maintenance tasks, refit ALL safety guards and features. **NEVER WORK WITHOUT THE GUARDS IN PLACE!**



11.3.1. Removing the belt guard

- Switch off the engine and remove the ignition key.
- Remove these 2 nuts and bolts below:
 - **(1)** - (M 8x20) 2x 13-mm wrenchs
 - **(2)** - (M10x25) 1x 17-mm wrench
- Remove the guard.

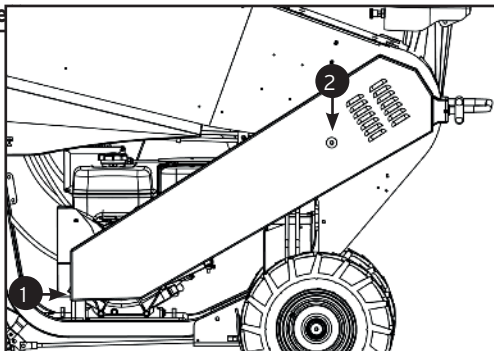

11.3.2. Removing the chain guard

- Switch off the engine and remove the ignition key.
- Remove the two M8x16 bolts **(1)**.
1x 13-mm wrench
- Remove the M10x25 bolt **(2)**. 1x 17-mm wrench
- You can now remove the guard.

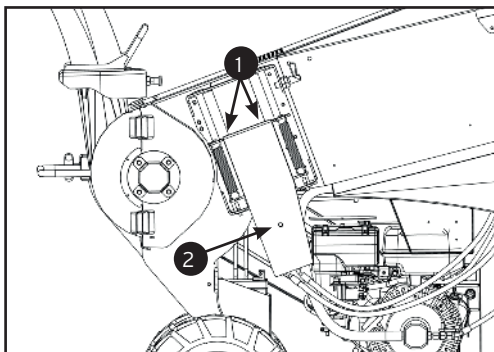

11.3.3. Disconnecting the battery

- First, disconnect the negative terminal **(1)** (black cable M6, 10-mm wrench).
- Then disconnect the positive terminal **(2)** (red cable M6, 10-mm wrench).

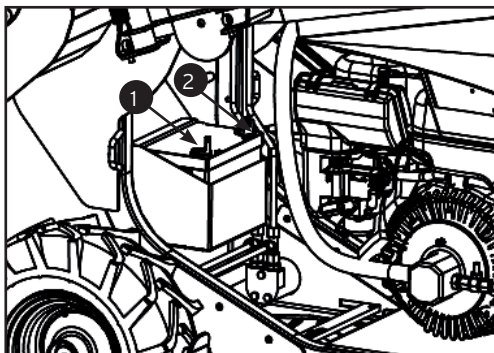
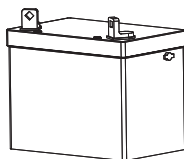

Caution:

First reconnect the positive terminal **(2)** (red cable M6, 10-mm wrench). Then reconnect the negative terminal **(1)** (black cable M6, 10-mm wrench). Never leave the battery disconnected for more than 1 day.

11.3.4. Opening the blade shaft compartment



Caution: Before opening the rear hatch, the blade shaft must be at a complete standstill. Turn off the engine and remove the ignition key.



Caution: Place the blow chute in the working position to open the rear hatch.

- To do, simply turn the handle counter-clockwise. The rear hatch opens like a door.
- To close the maintenance hatch, push the hatch against the lock and simultaneously turn it clockwise. Turn the screw until you feel resistance and finish screwing it in with one final half-turn.

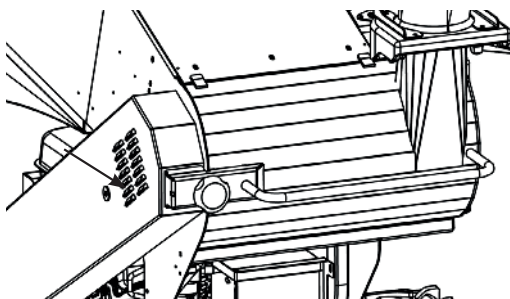

Warning: The blades are extremely sharp. Avoid all contact with the blades and always wear appropriate protective gear, such as gloves.

When the hatch has been closed completely, a safety switch will engage. When closing the hatch, listen for the sound of the switch engaging.



Caution: If the rear hatch is not closed properly, you will not be able to restart the engine.

11.3.5. Setting the blow chute to the working or lowered position



Caution: The machine can only be used if the blow chute is in the working position. The machine must never be started if the blow chute is still in the lowered position.

- Before the blow chute can be lowered into the transport position, the deflectors must be set to the lowest possible position. (see Section 9.6.2, page 35) Lock them in this position.

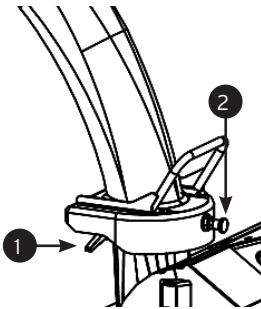
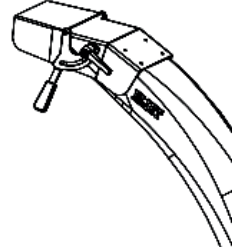

- To lower the blow chute, first turn the handle **(1)** beneath the chute.
- Turn the chute until it is entirely pointed towards the front of the machine and then pull on the locking tab **(2)**.
- Hold the blow chute by the handle and lower it as far as it will go.

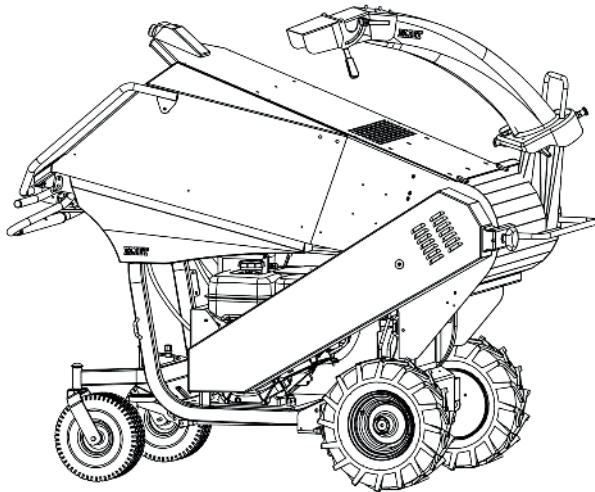

11.3.6. Manually lifting the feed roller



Warning: Lifting the feed roller may expose you to certain hazards. Always make sure to wear appropriate protective gear: gloves, safety goggles, etc.



Caution: Before lifting the feed roller, shut off the engine and remove the ignition key from the starter.

It may be necessary to manually lift the feed roller for certain maintenance operations or if the blade shaft has become blocked. Follow these instructions to lift or lower the feed roller:

- Turn off the engine and wait a few seconds for the shaft to come to a complete standstill.
- If possible, release the springs situated on either side of the feed roller (this step is not required). This will remove the need to fight against the resistance of the springs while lifting the feed roller.
- Lift the feed roller with two hands and keep lifting until the lock to keep it in place engages automatically.
- To lower the feed roller, lift it slightly to release the automatic lock. Lower the feed roller into its original position, guiding it down slowly with your hands.
- If you removed the two rails alongside the roller while lifting it, make sure to tighten the two fixtures at the bottom when the roller is lowered, and the two fixtures towards the top when the roller is lifted. See the image below:

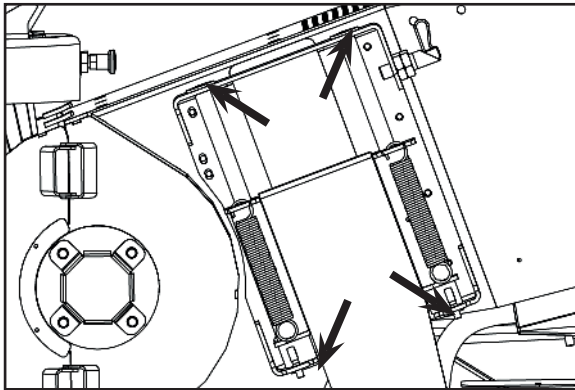

Warning: Put the springs back into their original position, and ensure that the lock is not still in the "active" position when you start using the machine again to shred. The lever could potentially lock the feed roller in the highest position while the machine is running and cause an uncontrolled amount of material to be fed into the machine.

11.4. Engine maintenance



Warning: When running, the engine emits carbon monoxide, an odourless and colourless poisonous gas. Inhaling carbon monoxide can cause nausea, fainting or even death.

Start the engine outside.

NEVER start the engine in an enclosed space, even with the windows and doors open.

11.4.1. Checking engine oil level + refilling

Inadequate oil level in the engine will cause irrevocable damage to the engine. Therefore, you should check the oil level regularly.

- Place the machine on a level surface so that the engine is perfectly horizontal.
- Switch off the engine and remove the ignition key.
- Take a clean cloth.
- Remove the dipstick **(1)** and use the cloth to wipe it clean (the oil level shown on the dipstick is not always correct the first time it is removed). Reinsert the dipstick and then remove it again. The oil level must reach the **"F" (Full)** mark on the dipstick.
- If this is not the case, you will need to top up the oil (**caution:** never fill it beyond the maximum level).
- Removing the dipstick will provide you with an opening to top up the oil.

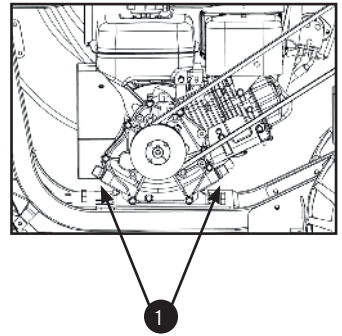

Caution: Topping up the oil must be done precisely. Overfilling the reservoir will be detrimental to the performance and life of your engine.

- Pour the oil into the reservoir slowly. Check the oil level on the dipstick while filling to see if the desired level has already been reached.
- Only use oil recommended by ELIET. See "17.1. Specifications for lubricants and fuel", page 82.
- Once the oil tank has been topped up, put the dipstick back in and tightly screw back on the filler cap.
- Immediately wipe off any spilled oil.



Caution: Make sure that no dirt enters the crankcase through the filler cap.

11.4.2. Changing the engine oil



Warning:

Filling the engine oil tank is done in TWO steps.
Read all of the text carefully!

- Make sure that the base of the engine is on a horizontal surface.
- Allow the engine to run until it reaches normal operating temperature, then switch it off (remove the ignition key).
- Place a receptacle 2 litre-3/4 US gallon below the oil drain plug **(1)**.
- Unscrew the filler cap **(2)**.
- Replace the drain plug **(1)** and allow the oil to drain into the receptacle.
- Once all of the oil has been removed from the crankcase, screw back on the drainage plug.
- Clean the edges using a cloth.
- Slowly pour fresh oil into the engine and then screw back on the filler cap. (Consult the engine manual for the exact quantity.)
- Wait about 2 minutes for the oil level to stabilise.
- Pour in oil until it reaches the **"F" (Full)** mark on the dipstick.
- Wipe off any spilled oil.

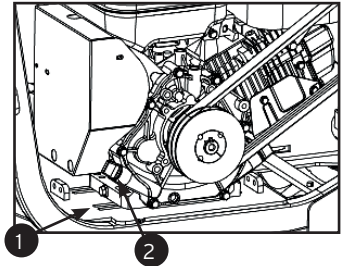

Warning: Insufficient oil in the engine can cause irreparable, serious damage to the engine. Any warranty claims stemming from a faulty oil level will be dismissed.

11.4.3. Cleaning the air filter



Caution: If the engine has just been stopped, the exhaust will still be hot.

- Undo the clamps retaining the cover of the air filter and remove the cover. (Subaru engine)
- Remove the two screws from the filter guard by hand and remove the guard. Vanguard engine:
- Before removing the filter, use compressed air to remove dust and dirt inside the filter housing.
- Carefully remove the pre-filter from the filter cartridge.
- Remove the nut and the sheet of the filter medium first, then remove the cartridge. (Try to avoid allowing any dirt from entering the carburetor.)
- Clean the cartridge by tapping it gently against a flat surface.
- Refit the cartridge (with the UP mark towards the top).
- Refit the pre-filter into the cartridge.
- Replace the cover and refit it by using the clamps (Subaru) or by retightening the two screws by hand (Vanguard).

11.4.4. Replacing the air filter

This operation is almost identical to cleaning the air filter. (see Section 11.4.3, page 57) The only difference is that the cartridge is replaced.

New air filters of the correct type are available from your ELIET dealer or from other authorised dealers.

11.4.5. Changing the engine fuel filter

- Switch off the engine and remove the ignition key.



Warning: Allow the engine to cool down completely. This will help prevent any risk of fire or explosion.

- Loosen the clamps **(1)** using universal pliers.
- Remove the filter from between the fuel lines.
- Insert the new filter (making sure to insert it with the arrow on the filter in the correct direction). New filters are available from your ELIET dealer. Order code: BM 260 493 629
- Slide the clamps onto the section of the fuel hose that rests on the filter.
- Retighten the clamps.
- Wipe off any spilled petrol (UK)/ gas (USA).
- Start the engine and inspect for signs of leakage.

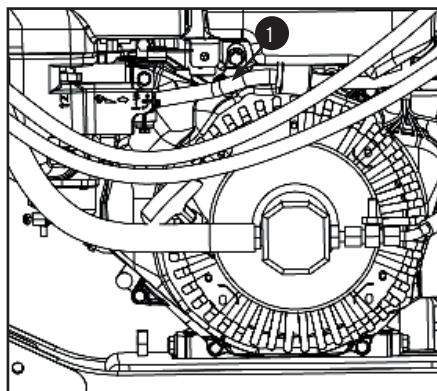

11.4.6. Refilling the hydraulic fluid

- Make sure that the engine is on a horizontal surface.



For your information: While changing the oil during maintenance, it is important to also change the oil filter.

Ensure that you have a 12 litres - 3.5 US gallon receptacle and a funnel on hand.

- Unscrew the fuel filler cap to allow air to enter.
- Place the funnel below the oil filler plug and remove the filter.
- Allow the oil to flow into the receptacle through the funnel.
- Place a new oil filter into the fixture. See "11.4.7. Changing the hydraulic fluid filter", page 59.

TIP:

Use a clean funnel equipped with a filter to prevent the introduction of any dirt.

- Fill the tank with 10 litres - 10 US qt of fresh hydraulic fluid and screw back on the filler plug. "17.1. Specifications for lubricants and fuel", page 82
- Wipe off any spilled fluid.

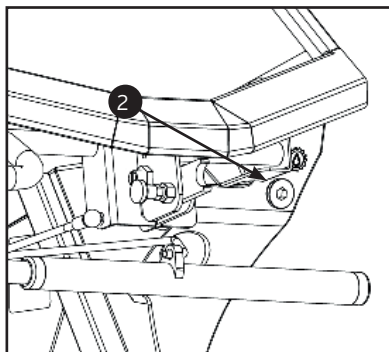
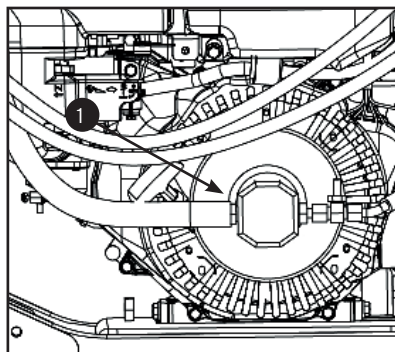

11.4.7. Changing the hydraulic fluid filter

The hydraulic circuit is a closed circuit. As the machine is operating, the fluid is contaminated by the wear to which the hydraulic elements are subjected, as well as by the poppet valve in the tank. The fine particles that enter the fluid are filtered out by a filter cartridge. Over time, this filter cartridge will be changed at the same time as the hydraulic fluid.

This filter is located beneath the hopper, behind the fuel tank.

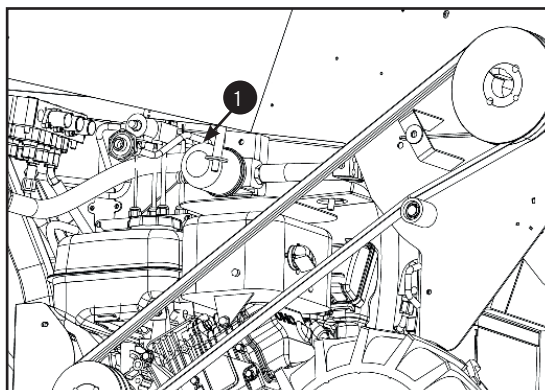

When replacing the filter, also change the hydraulic fluid. See "11.4.6. Refilling the hydraulic fluid", page 58.

The filter cartridge includes a central filter which is screwed into the cartridge fixture.

Unscrew the filter cartridge by turning it counter-clockwise.

Completely unscrew the cartridge and allow the remaining fluid to flow through the funnel. -Wipe away the fluid and also clean the filter cartridge fixture.

New filter cartridges are always obtainable from your authorised ELIET dealer. Order code: BH 280 212 010

- Soak the new filter's gasket in hydraulic fluid to moisten it.
- Now screw the new filter cartridge onto the fixture by hand.
- Once the cartridge has been attached to the fixture, make a further $3/4$ turn to ensure that the seal is tight.
- Fill the hydraulic fluid tank.
- Replace the hydraulic filler plug.
- Start the engine and engage the starter to circulate the fluid and warm up the machine.
- Ensure that the entire fluid circuit is well sealed (no leaks)
- Clean any fluid that has spilled with paper, and dispose of wet cloths as chemical waste.
- The filter cartridge will also be disposed of as chemical waste.

11.5. Machine maintenance

11.5.1. Routine inspection of the blades

Machine performance and shredding speed greatly depend on the condition of the blades. Enhance your own work comfort by taking the time to check, tighten and sharpen the blades, if needed, every time you are about to use the machine.

SHARP BLADES = OPTIMAL PERFORMANCE

Pay particular attention to the following: Shredding green waste with the ELIET shredding system is done in two steps. The blades first come into contact with the green waste when it reaches the chopping block. During this **initial cutting (1)**, wood and leaves are coarsely chopped into large, irregular chunks. These large chunks then go into the shredding chamber where they are finely chopped to produce small chips. This is the second cutting **(2)**.

Wood chips move through the shredding chamber until they reach the impeller at the end of the blade shaft **(3)**. They are then ejected by acceleration through the blow chute **(4)**.

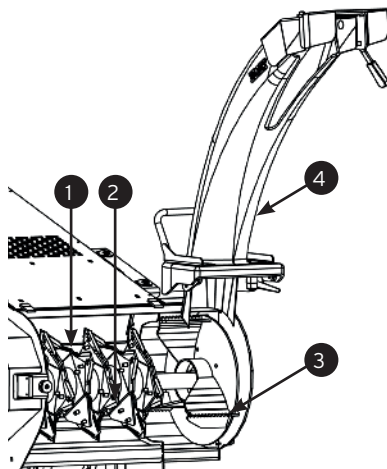

Each of these cutting actions sets certain criteria that the blades must meet for optimal shredding efficiency:

- The tips of the blades, in particular, are important with regard to the initial cutting. Since the blades act as splitting blades, **the cutting angle** is essential because this is the part that cleaves through the wood. The cleaving angle of the cutting edge of the blades should preferably be 30°. The sharper the blade edges, the less resistance they will encounter when splitting wood. This will lead to a smaller impact on the machine itself. It will create a significant reduction in vibrations and noise. It will also benefit the blade shaft and bearings. You should sharpen the blades at regular intervals in order to maintain an optimal splitting angle. (see Section 11.5.2, page 62)

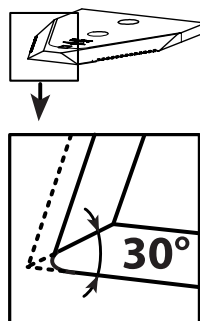

- In addition, the shape of the blade tips is also extremely important for the proper performance and speed of the initial cutting. The angle of the **blade tips** determines how the wood is pulled into the shredding chamber. If a blade tip is rounded due to wear, turn the blade around or replace it. See “11.5.3. Turning or replacing the blades”, page 64.

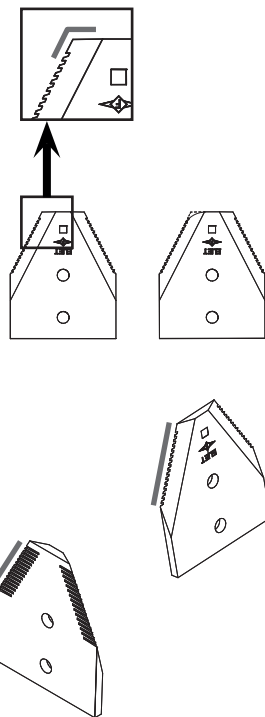

- The goal is to have the chips ejected as quickly as possible from the shredding chamber for the secondary cutting. This means they must be chopped down quickly in order to be ejected rapidly. As such, the chips must become smaller every time they are in contact with the cutting edge of a blade. The sharper an active cutting edge, the more efficient shredding will be. As such, it is essential to regularly sharpen the cutting edges of the blades and to make sure that the blades are held tightly in place.
- The teeth on the cutting edge provide increased cutting power to the blades and also ensure that the cutting edge remains sharp for a longer period of time. While performing maintenance operations, it is very important to avoid sharpening the teeth of the blades. See “11.5.2. Sharpening the blades”, page 62.

The positioning of the blades on the blade shaft was purposefully chosen to create alternating chopping during the initial cutting and the proper introduction of the wood chips into the shredding chamber during the second cutting. Always respect the original configuration of the blades when turning or replacing them. (“11.5.3.1. How to turn a blade”, page 65 for instructions.)

11.5.2. Sharpening the blades

Correct and timely sharpening (we recommend at least every 10 working hours) will extend the duration and operating life of the blades.

- Remove the key from the ignition for your own safety.
- Open the shredding chamber. (see Section 11.3.4, page 53)

Preparatory warnings

- Always wear safety goggles and hearing protectors when sharpening blades. Gloves are also mandatory for performing any type of maintenance work.
- NEVER turn the blade shaft by grabbing the blades directly. To turn the shaft, use the ejection impeller.



Warning: Mind your hands, and ensure that they do not become wedged between the fan and the turbine.

- Each blade has two cutting edges (reversible blade). As such, you must keep in mind that the other side of the blade could also be extremely sharp as you sharpen the other side.
- Remove all wood dust and chip residue from the shredding chamber and from the Turbo. This will remove the risk of starting a fire from their contact with smouldering sparks created by sharpening.



For your information: The blades can be sharpened without having to remove them. You can use a small angle grinder fitted with a grinding disc suitable for metal.

Each blade has two sides:

- The front of a blade has two bevelled cutting edges. **(F)**
- The teeth profile of the cutting area is clearly visible on the backside of a blade. **(B)**

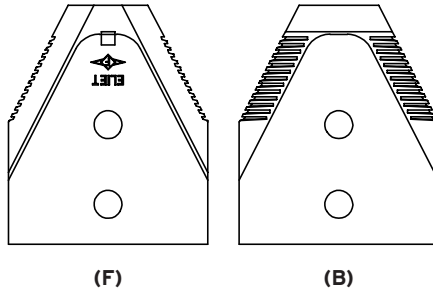

As described in Section "11.5.1. Routine inspection of the blades", page 61, a sharp cutting edge and a correct cutting angle are essential for efficient shredding. These two blade properties are easily obtained by sharpening the blades correctly.

- When blades become blunt, their sharp cutting edges appear worn and take on a more noticeable ribbed appearance. **(1)**
- By grinding a little metal from the cutting edge, you can again obtain a sharp cutting edge from this wide ribbed appearance. **(2)**

- To do so, move the grinding disc along the ribbed edge.
- **Note:** Regular sharpening will reduce the amount of metal you need to remove in order to obtain a sharp cutting edge again. As a result, you will spend very little time on this operation to obtain perfectly sharp cutting edges. (ELIET recommends grinding after every 10 working hours.)

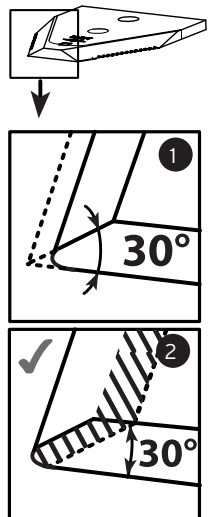

- Avoid grinding at the same location for a long period of time. This will prevent local discolouration of the blades, which indicates overheating and a modification to the actual structure of the material (and its hardness) at that point.
- It is essential that you do not change the cutting angle of the blade as you are sharpening it. **(3: badly-sharpened blade)**
- Failure to maintain the cutting angle by blunting the angle **(4)** or changing it in any other way **(5)** will cause the blades to become stuck while cutting wood, leading to a less powerful machine. A cutting angle that is too sharp **(6, 7)** will lead to weaker cutting edges, which will considerably reduce the duration of the blades **(see figures 4, 5, 6 and 7)**.

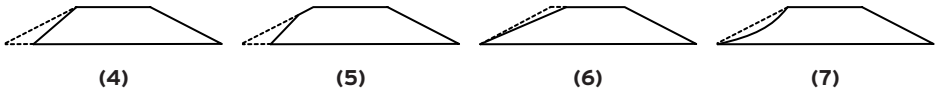
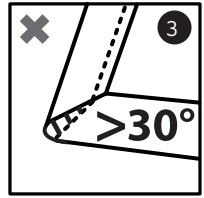

- Never grind the backside of a blade.
- The tip of a blade is subjected to the heaviest use during shredding. As such, sharpening the tip should only be done when strictly necessary to avoid weakening it.
- Each time a blade is sharpened, a bit of material is lost, reducing the active cutting edge. You can grind the cutting edge until you have reached halfway through the width of the tip of the blade. If you go beyond this limit, you could compromise the duration of the cutting edge that has not been used yet. If this happens, you should turn the blade. (see Section 11.5.3, page 64)
- If the tip of a blade is rounded, shredding efficiency will be reduced. In that case, continued sharpening serves no purpose. This would mean that you need to either turn or replace the blade. (see Section 11.5.3, page 64)
- After you have finished sharpening the blades, carefully close the shredding chamber. (see Section 11.3.4, page 53)

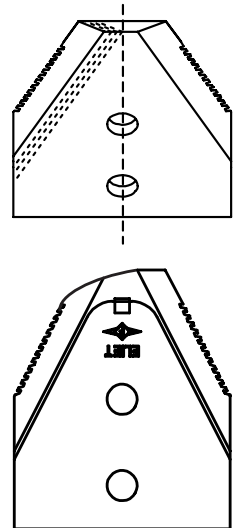

11.5.3. Turning or replacing the blades

If blades are sharpened at regular intervals, a duration in excess of 100 hours for each cutting edge can be obtained. Once one cutting edge has been worn down, a blade can be turned. This new cutting edge can also be used for 100 hours. Once both blade edges have been worn down, the blade itself will have to be replaced.

11.5.3.1. How to turn a blade



Warning: You must wear protective gloves, since the blades are extremely sharp!



Warning: The blade system is directly exposed as soon as the shredding chamber is opened. Ensure that the machine has completely stopped and remove the key from the ignition.

- Remove the ignition key from the machine.
- Open the shredding chamber.
 - No tool is necessary for opening the chamber. It has a quick and easy-to-use system for opening and closing it.
 - See "11.3.4. Opening the blade shaft compartment", page 53.



For your information: The blades are extremely sharp. Avoid contact with the blades and always wear appropriate protective gear, such as gloves.

- Each blade is secured with two M8 bolts. Avoid injury to hands and always use two ring wrenches with long handles to unscrew the bolts.
- If any of the bolts are damaged, they must be replaced immediately.
- Do not pull the blades out with your hands; use locking pliers instead.
- It is useful to put a wedge (screwdriver) between the blade discs in order to remove the blades more easily.

There are certain rules that must be respected for turning or replacing a blade. The blade shaft is divided into two groups to respect the logic of these rules:

- **Blade group 1:** This group is made up of the two blade discs at both ends of the shaft. **(G1)**
- **Blade group 2:** This group is made up of the 4 blade discs that are enclosed between the two exterior blade discs. **(G2)**

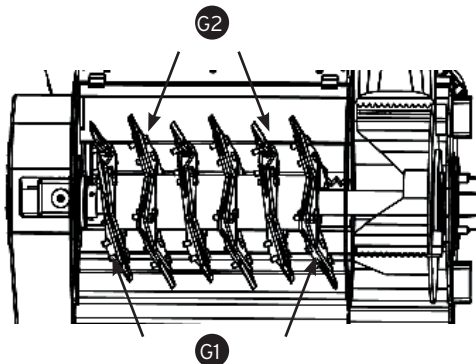



For your information: Each blade has two sides (illustration)

Front side (F): the bevelled cutting edge is visible.

Back side (B): The side with the clearly visible tooth profile.

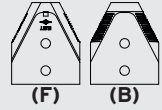

A. Turning / replacing blades in group 1

Rule: Ensure that the blades in group 1 are always oriented with their back sides (B) facing the side walls of the shredding chamber.

Perform the following steps to ensure that this rule is applied consistently.

- Remove a single blade from the left-side blade disc, rotate it 180° and put it back in the same position, but on the right-side blade disc. Rotate (180°) the blade previously removed from the right-hand blade disk, and fit it in the empty space in the left-hand blade disk.
- Repeat this procedure until all 8 blades from group 1 in both discs have been repositioned.
- Always clean the blades and blade holders before refitting them.

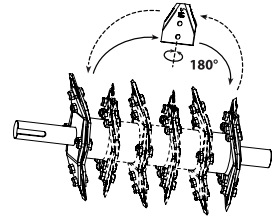
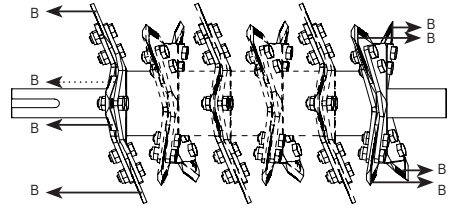

B. Turning / replacing blades in group 2

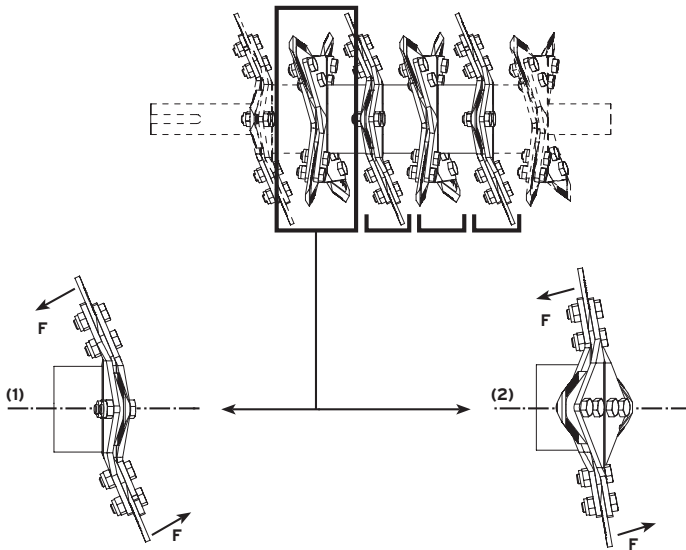

Rule: Every blade disc has four blade positions. The blades are positioned at an angle for two positions (1), whereas they are relatively straight for the two other positions (2). The front side (F) of the angled blades must always be facing the shaft. For the straight blades, the

front side (**F**) of one of them must face towards the right, and the other must face towards the left.

Perform the following steps to ensure that this rule is applied consistently.

- Remove two blades that are diametrically opposite each other. Rotate them 180° and reposition them. Do the same with the two remaining blades. Repeat this operation for the three remaining blade discs of group 2.
- Always clean the blades and blade holders before refitting them.

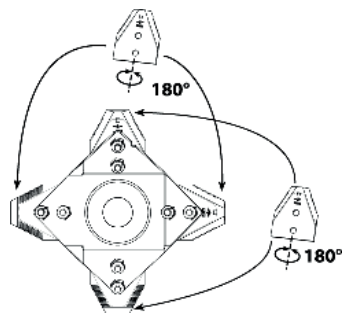

Caution: When refitting the blades, always position the nuts on the left-hand side of the blade disc. By applying this installation method, the nuts will automatically be tightened during shredding by the turning direction of the blade shaft.

As a reminder: Always position the nuts on the belt pulley side.

11.5.3.2. How to replace a blade

- The new set of RESIST/8™ blades for the Prof 6 is available from your ELIET dealer under the reference: BU 101 300 800.
- Remove all M8 bolts securing the blades. Always use two ring wrenches with long handles to unscrew these bolts.
- Do not pull the blades out with your hands; use locking pliers instead.
- It is useful to put a wedge (screwdriver) between the blade discs in order to remove the blades more easily.
- First remove any dirt between the blade discs before you insert a new blade. Use a painting knife to do this.
- Now carry out the steps that must be followed to turn the blades: See "11.5.3.1. How to turn a blade", page 65.

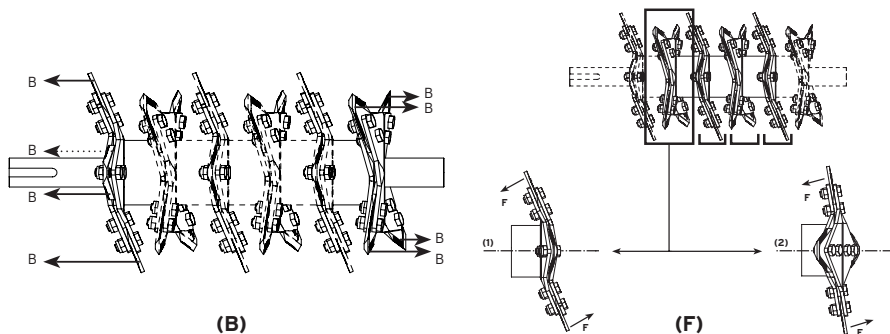

Group 1: The back side (**B**) of each blade must face the wall of the shredding chamber.

Group 2: The front side (**F**) of each blade that is fitted into the inclined part of a disc must face the blade shaft.

- Always use new nuts and bolts when replacing a blade.
- Tighten the bolts when refitting the blades. See “17.2. Torque chart”, page 83.
- When tightening the bolts in the blade discs, always make sure the nut is located on the left side of the disc. As a reminder: All nuts in the blade shaft must always be positioned along the side of the pulley belt.
- After turning or replacing the blades, always check the torque of the blade bolts and adjust if needed.



Caution: Always check the torque of the blade bolts after the first 5 working hours!



Caution:

Poorly installed blades may lead to the machine breaking down or being damaged. It will also put operators and bystanders in danger. Failure to retighten the blades after the first 5 working hours and/or after turning or changing the blades may lead to the machine breaking down or being seriously damaged, as well as to serious injury and even death. Any consequential damage that may arise from the poor maintenance of the blades will invalidate any applicable warranty claims.

11.5.4. Checking the tension of the drive belt

The Prof 6 is equipped with a drive belt. This is hidden behind a belt guard as an extra safety precaution. In order to check the tension of the belt, proceed as follows:

Belt: engine - blade shaft

- Remove the belt guard. See "11.3.1. Removing the belt cover", page 52.
- Place a 7-kg weight on the belt midway between the two belt pulleys.
- If this produces a 1-cm deflection, then the belt tension is correct.

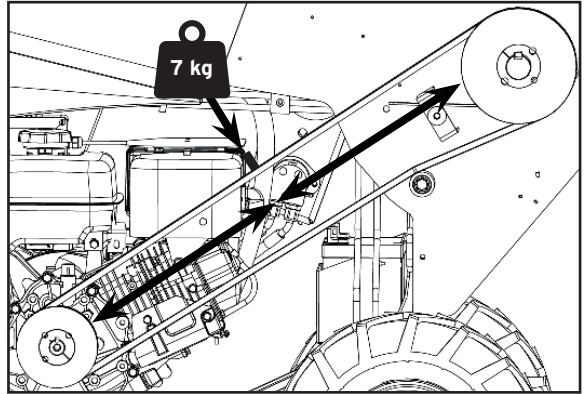

11.5.5. Checking the alignment of the pulleys / Replacing the belt

Belt: engine - blade shaft

- Loosen the guide bolts (**3 & 4**) and unscrew them 2 cm - 1".
- Position metal plates between the base of the engine and the bolts (**3 & 4**), and retighten the bolt (**4**).

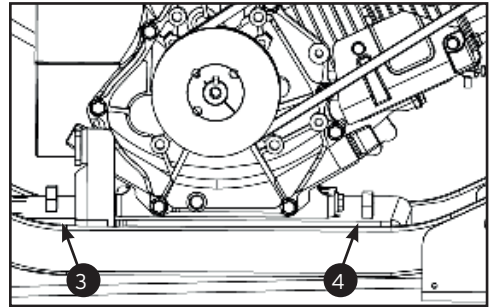

- Slightly loosen the 4 bolts on the engine (**5, 6, 7, 8**) (M10, 17-mm wrench).
- Move the engine by moving the clamping bolt (**4**) to tighten the belt.
- Ensure correct belt tension. See "11.5.4. Checking the tension of the drive belt", page 69.
- Repeat the above operation as described until the correct tension is obtained.

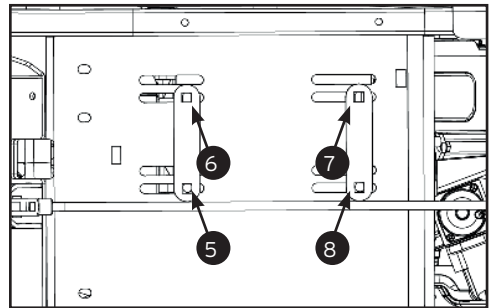

Pulley alignment:

Tool: 1 meter - 4ft straight edge

- Verify the alignment of the pulleys by placing a straight edge on the exterior face of both pulleys. When the alignment is correct, the straight edge will touch the belt pulleys at 4 locations.

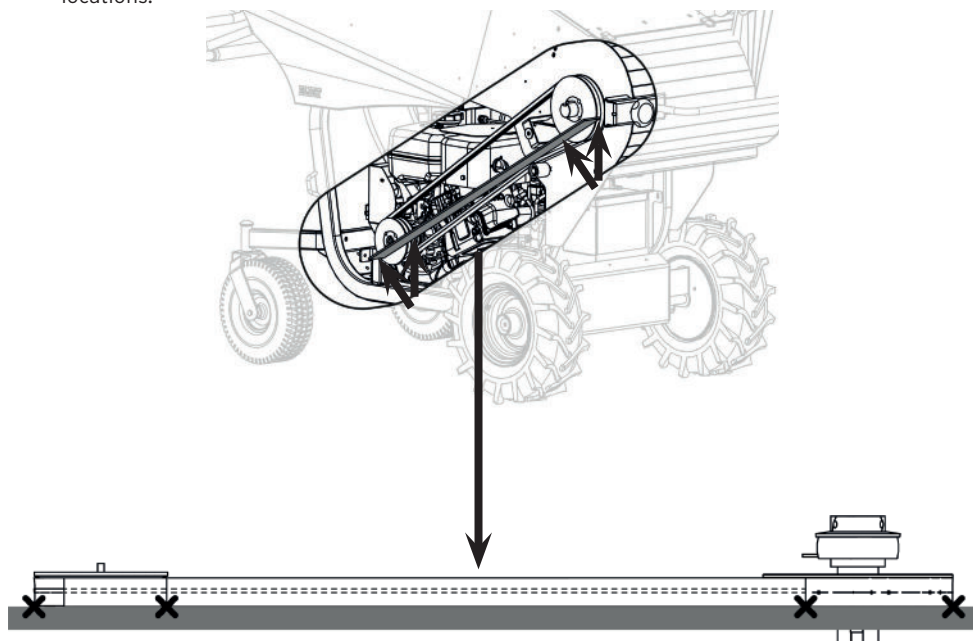

- If the alignment is not correct, move the bolt **(3)**.
- Verify the alignment and repeat the operation until the straight edge comes into contact with all 4 points.
- Retighten the four engine bolts **(5, 6, 7, 8)**.
- Remove the two metal plates between the engine base and the bolts **(3 & 4)**.
- Now retighten the guide bolts **(3 & 4)** against the engine, and tighten the locknuts.

11.5.6. Checking the tension of the feed roller transmission chain

- Remove the chain guard. See "11.3.2. Removing the chain guard", page 52.
- Check the tension of the chain.
- If the chain is too slack, loosen the bolts **(1 & 2)** (M8, 13-mm wrench).
 - Make the chain taut by tightening the nut **(3)** on the threaded rod. (M6, 10-mm wrench)

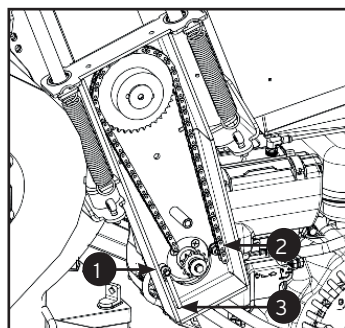



Caution: The chain should not be too taut.

- When the chain tension has been properly adjusted, retighten the bolts **(1 & 2)** (M8, 13-mm wrench).
- Refit the chain guard. See "11.3.2. Removing the chain guard", page 52.
- Lubricate the chain properly. (see Section 11.5.8.15, page 75)

11.5.7. Checking and adjusting the tension of the tracks (Cross Country model)

A. Checking for correct tension:

- The track is sufficiently taut if it comes 1 cm - 1/2" off the upper guide when it is lifted.
- If the track comes off more than 1 cm, the tension needs to be corrected.

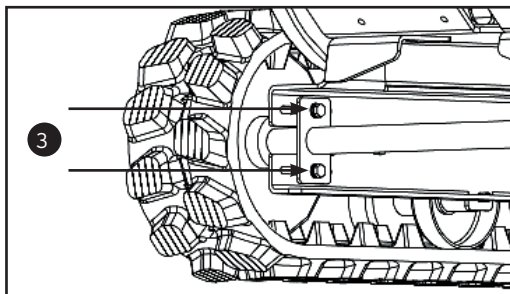

B. Adjusting the tension:

- Loosen the locknut **(2)** and the two clamping bolts **(3)** (M12, 19-mm wrench).
- Tighten the central bolt **(1)** (M12, 19-mm wrench) to adjust the track tension.
- Check the tracks again for correct tension and tighten the central bolt **(1)** even more if necessary (or loosen it if the track is now too taut).
- Remember to tighten the clamping bolts **(3)**, as well as the locknut **(2)**.

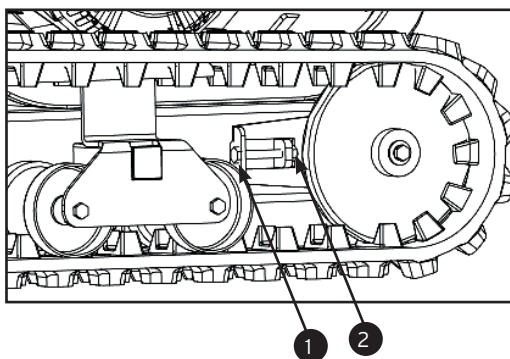

11.5.8. General lubrication

Given that shredders often operate in extreme conditions, ELIET believes it is important to use high-quality lubricants. ELIET therefore recommends the use of special lubricants from the assembly stage onwards.

The following parts require regular lubrication:

- Pivot points and friction surfaces. See "11.5.8.1. Lubrication of pivot points and friction surfaces", page 72.
- Grease fittings. See "11.5.8.13. Lubricating using the grease fittings", page 73.
- Bearings. See "11.5.8.14. Lubricating the bearings", page 74.
- Chains and cogs. See "11.5.8.15. Lubricating the chains and sprockets", page 75.



Caution: Before performing lubrication operations, always make sure to switch off the engine and remove the ignition key. Gloves must also be worn while performing this maintenance work.

11.5.8.1. Lubrication of pivot points and friction surfaces

11.5.8.1.1. This group includes the following locations on the machine:

- a. Wheel control handle pivot points.
- b. Guiding blanking plate for the feed roller.
- c. Throttle lever pivot point. Starter lever.
- d. Hinges on the rear shredder hatch.
- e. Safety bracket pivot points.
- f. Feed roller controls.
- g. Wheel brake guide.
- h. Parking brake foot pedal.
- i. Blow chute pivot point.
- j. Hinging points on the deflector.
- k. Feed roller hinges.
- l. Rear wheel shafts. (Grease fittings)

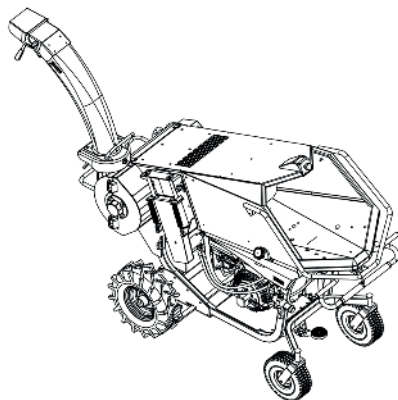

- Whenever possible, disassemble the hinge or pivot point.
- Spray penetrating oil containing molybdenum disulphide onto the friction surfaces and allow the oil to penetrate.
- Wipe away all traces of old lubricant and dirt.
- Should some parts not be accessible, use compressed air to remove all traces of old lubricant and dirt from the joints and pivot points.
- When pivot points are clean, apply new lubricant.
- ELIET recommends Novatio Clear Lube as a lubricant for pivot points and rolling bearings. Novatio PFT lubricant is more suitable for friction surfaces.
- Wipe away any excess lubricant.

11.5.8.13. Lubricating using the grease fittings

11.5.8.13.1. Grease fittings for small doses

This group includes the following locations on the machine:

- Grease fitting on the pivot point of swivel wheels.
- Grease fittings on the bearings of swivel wheels.

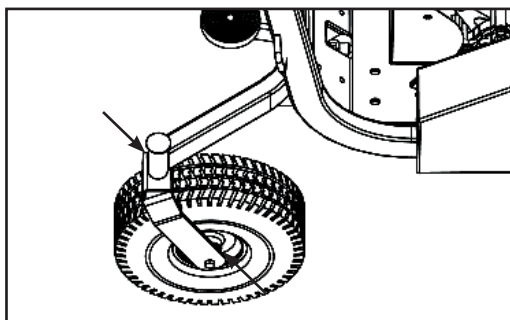

11.5.8.13.2. Grease fittings for large doses

- Grease fittings on the rods of the feeding roller (1)
- Transmission grease fittings in the rear rims (2)

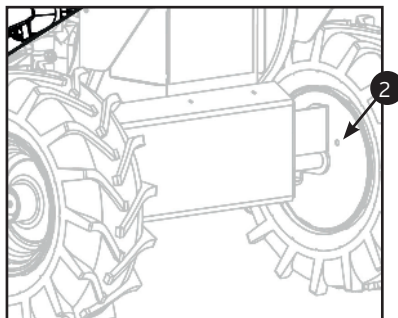
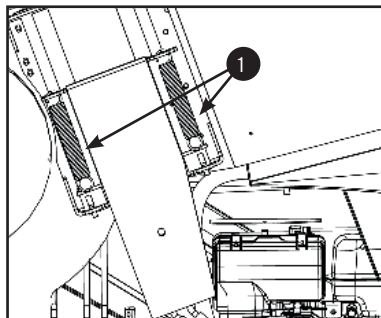

Use the following procedure:

- Clean the grease fitting.
- Use a suitable grease pump to inject fresh grease into the grease fitting.
- ELIET recommends using MOBILGREASE XHP222.
- Pumping the grease gun one or two times is sufficient to inject enough grease.
- Wipe away any grease that comes out of the joints.

11.5.8.14. Lubricating the bearings

This group includes the following locations on the machine:

Blade shaft bearings.

Use the following procedure:

- Spray some penetrating oil containing molybdenum disulphide onto the bearing and the area around it, and allow the oil to penetrate.
- Wipe away any dirt stuck to the outside of the bearing.
- Spray more penetrating oil into the bearing joints.
- Turn the bearing. You could even start up the mechanism that turns the bearing (**Caution:** Make sure that all dangerous areas are adequately shielded).
- Wipe away any dirt that is forced out by the penetrating oil.
- Use compressed air to remove excess penetrating oil from the bearing and the bearing joints.
- Apply new lubricating oil. ELIET recommends Novatio Clear Lube as a lubricant.
- Wipe away any excess lubricant.

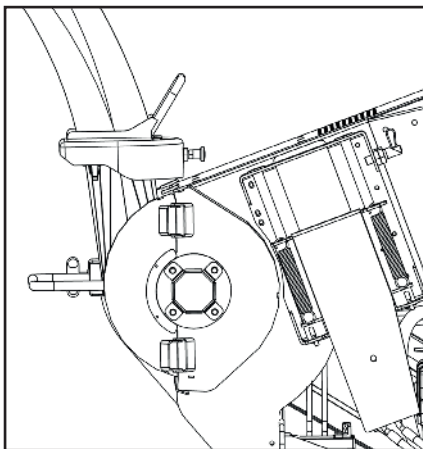

11.5.8.15. Lubricating the chains and sprockets

This group includes the following locations on the machine: Chain drive of the feed roller.

Use the following procedure:

- Expose the chain by removing the chain guard. See “11.3.2. Removing the chain guard”, page 52.
- Wipe away all grease and lubricant in and around the drive.
- Spray penetrating oil containing molybdenum disulphide to dissolve dirty lubricant.
- Clean away any remaining oil and clean the chain by blowing on it.
- Apply new lubricant once the drive has been cleaned.
- Use a small brush to apply grease to the teeth of the sprockets.
- Multi Purpose Grease or a product of the same quality.
- It is better to use a liquid lubricant on chains so that it can penetrate into them. ELIET recommends using Novation Clear Lube spray.
- After applying the lubricant, carefully refit the guards, trying as much as possible to keep out dust and dirt.

All of these products are available from your ELIET Dealer.

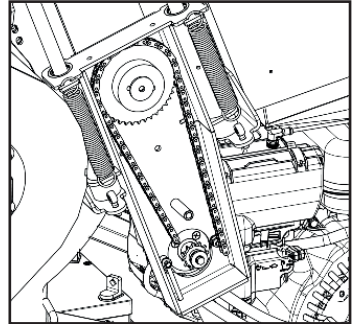

12. Storing the machine



- Clean the machine. See “11.2.2. Daily maintenance”, page 50.
- Store the machine in a dry place that is protected from rain, and if necessary, cover it with a tarpaulin.
- Always allow the machine to cool down before storage.
- If the machine needs to be stored outside, it must be well protected with a tarpaulin. Try to avoid allowing the machine to be exposed to bad weather. At ELIET, we strongly recommend that the machine be stored in a dry location.
- Before storing the machine for longer periods, it is recommended to perform the following steps:
 - Conduct maintenance after 50 hours.
See “11.2.6. Maintenance after 50 hours of use”, page 51.
 - Check all nuts and bolts for correct tightness, retighten them if necessary.
 - Touch up or lubricate areas where the paint coating has been removed to prevent rusting. Original ELIET paints in the same colour are available from your ELIET dealer (article number: BX 043 200 400).

13. Options

- **ABM System (Anti-block motor) MA 032 001 001:** You can choose to have your Prof 6 equipped with an ABM (Anti-Block Motor) system, this system will stop the feeder if the RPM drops (to avoid the engine to stall) and will restart the feeder automatically once the RPM is back up.
- **Oil flow regulator MA 032 001 002:** You can equip your shredder with an infeed speed controller, which will enable you to regulate how much oil is being supplied to the feeder, thereby increasing or decreasing the speed at which material is fed into the machine.
- **Ejection tarpaulin MA 032 001 003:** You can fit the blow chute with a special tarpaulin that enables you to precisely direct wood chips vertically. For example, into a wheelbarrow.
- **Hoisting hooks MA 032 001 004:** In order to hoist the machine safely, it can be equipped with hoisting rings.

14. Risks

- Be sure to read the below list of hazards and risks associated with storing, transporting and/or working with this shredder. Take note of these dangers and avoid these risks by following the instructions contained in this manual.
- Keep in mind that not only is the operator in danger, but any bystanders are also exposed to these risks.
- Keep all bystanders at a safe distance.
- Risk of injury to the hands if they come into contact with the feed roller.
- Risk of catching and crushing body parts that come into contact with the feed roller.
- Risk of strangulation after catching clothing in the feed roller.
- Risk of being strangled, trapped or disfigured by the machine if loose-fitting clothing becomes caught in the feed roller.
- Risk of injury from wood chips ejected into the feed hopper.
- Risk of suffering injuries due to projection along the feed and discharge sides after a foreign object has been introduced (stone, metal, textile, PVC, etc.).
- Risk of injury due to wood chips being ejected around the opening of the blow chute when the machine is operating.
- Risk of suffering serious injuries or death because a machine part (blades, bolts, etc.) has become loose, due to a lack of regular maintenance and monitoring.
- Bruises and injuries may occur while feeding material into the machine due to the force of the blades on the wood.
- Contusions and injuries may occur due to sudden movements by the wood as it is introduced into the feed hopper.
- Risk of injury and cuts to the hands if they come into contact with the blades after opening the shredding chamber.
- Risk of injury through contact with the blades or cutting elements during unclogging, maintaining or cleaning the machine.
- Risk of crushing or catching your fingers between the impeller blades and the turbine during maintenance.
- Risk of cutting your hands if a wrench slips while loosening or tightening the blades.
- Always use high-quality, long-handled wrenches!
- Risk of crushing your hands or fingers while closing the maintenance hatch.
- Risk of crushing or catching your fingers between the hopper, anti-projectile shield and feed roller.
- Risk of crushing, catching or cutting off your fingers when the drive belt has been started.
- Risk of crushing, catching or cutting off your fingers when the transmission chain is moving.
- Risk of crushing your hands from moving springs or feed roller compression.
- Risk of crushing or injuring your hands by lowering the blow chute in an uncontrolled manner.
- Risk of burn injuries when touching the exhaust pipe or other engine parts when they have not yet cooled down.
- Risk of fire from wood chips and wood dust residue blocking the cooling fins.
- Risk of fire due to fuel catching fire during refuelling.
- Risk of poisoning from ingesting fuel, oils or lubricants.
- Risk of burns or skin irritation from contact with fuel, oils or lubricants.

- Risk of injury, puncturing the skin or blindness due to contact with a stream of highly-pressurised oil in the event of a leak in the hydraulic circuit.
- Risk of poisoning from exhaust fumes while the motor is running in an enclosed space.
- Risk of respiratory system irritation or pulmonary problems due to inhaling dust produced by the machine.
- Impairment of hearing due to insufficient ear protection while working.
- Nervous or rheumatic problems after long periods of shredding without resting.
- Risk of joint pain due to the vibrations caused by continually feeding thick branches into the machine.
- Risk of electrocution when touching the high-tension engine ignition line.
- Risk of overloading the spinal cord or back muscles if the machine is not placed at an ergonomic level for working.
- Risk of crushing or bruising the lower parts of the body while moving the machine.
- Risk of crushing your feet between the tracks and driving elements.
- Risk of strangulation or becoming stuck if loose-fitting clothing is pulled into the driving mechanisms or the tracks.
- Risk of becoming crushed between the machine and an obstacle while moving it in reverse.
- Risk of becoming stuck beneath the machine if it falls over during loading or unloading.
- Risk of the machine falling if it is not hoisted or coupled correctly.
- Risk of becoming stuck between the driving handle and an obstacle while moving the machine through narrow passageways or operating it.
- Injury due to a fall when driving on a surface that cannot bear the weight of the operator and the machine.

This list is incomplete and is provided for informational purposes only in regards to the safety of the operator.

15. Equipment specifications



	PROF 6 (ZR)	PROF 6 Cross Country	PROF 6 On Road
Choice of engine	B&S Vanguard 14 HP Subaru 14 HP		
Engine starting system	electric		
Type	petrol (UK)/ gas (USA)		
Number of cylinders	1		
Cubic capacity (cc)	408/404		
Horsepower (rpm)	10.3 / 14 (3500)		
Engine cooling system	Air cooling system		
Fuel tank capacity	11 litres - 2,9 US gallons		
Max. branch diameter	100 mm - 4"		
Output	4 m ³ - 5.5 cubic yard wood chips/hour		
Blade shaft	6 discs, 24 Eliet Resist™ blades/8		
Cutting frequency	48,000 cuts/min		
Transmission	V-type XPA 2240 belt x 2 power bands		
Feed roller drive	hydraulic Ø 156 mm - 6"		
Hydraulic fluid tank	10 litres - 2.6 US gallons		
Battery	12V		
Power control	ELIET ABM (Anti-Block Motor system)		
Safe and ergonomic infeed height	feeding height: 1,000 mm - 39" / infeed hopper opening: 560 x 600 mm - 22" x 24"		
Discharge system	discharge height 1,900 mm/projection distance 0,5 m ⇔ 15 m foldable blow chute for transport (H: 1,500 mm)		
Dimensions (LxWxH)	1,900 x 860 x 1,670 mm 6ft x 34" x 5 1/2ft low centre of gravity	1,900 x 860 x 1,670 mm 6ft x 34" x 5 1/2ft	1,900 x 1,475 x 1,670 mm 6ft x 5ft x 5 1/2ft
Noise level	115 dB(A)	115 dB(A)	115 dB(A)
Wheel drive	2 x hydraulic motors (32 cc)	2 x hydraulic motors (250 cc)	-
Wheels	Wheels 6.5 x 8"	Tracks 150 x 72 x 34 cm 59 x 28 x 13"	-
Weight	362 kg - 798 lbs	441 kg - 973 lbs	425 kg - 937 lbs
Speed regulator	option	option	option
Agricultural wheels	Standard	-	-

16. EC Declaration of Conformity



Machine.....Shredder
TypeELIET Prof 6
Model number: MA 032 010 439.....ON WHEELS 14 HP Subaru EX40 ES
Model number: MA 032 020 439.....CROSS COUNTRY 14 HP Subaru EX40 ES
Model number: MA 032 030 439.....ON ROAD 14 HP Subaru EX40 ES

The previously mentioned machine has been designed and manufactured to comply with the following standards:

EN 13515: Forestry machinery: wood chippers - safety

The ELIET manufacturing company hereby declares that it has conducted a risk analysis, and that it is fully aware of the potential hazards and risks associated with the machine. In this knowledge, the necessary steps have been taken in line with Machine Directive 2006/42/EC in order to ensure absolute safety for the operator when the machine is used correctly. The values of the measured sound power level and the guaranteed sound power level were obtained according to the procedures set forward in the directive 2000/14/EG annex III/B clause 50.

Measured sound power level (Lw(A)): 114 dB(A)
Guaranteed sound power level (Lw(A)) : 116 dB(A)

Date: 15/02/2020
Signature:

A handwritten signature in black ink, appearing to read 'Frederic LIETAER', written over a horizontal line.

Frederic LIETAER
Manager at ELIET EUROPE S.A.
born 02/01/1975

ELIET EUROPE S.A.
Diesveldstraat 2
B-8553 Otegem
Belgium
Telephone: +32 56 77 70 88
Fax: +32 56 77 52 13
E-mail: info@eliet.eu

17. Appendices

17.1. Specifications for lubricants and fuel

Engine oil.....	synthetic oil SF, SG, SH, SJ
Viscosity.....	SAE 5 W 30 / SAE 10 W-30
Capacity of Subaru 14 HP/B&S Vanguard 14 HP* engine crankcase	1.2 L - 40 oz.
Fuel.....	Unleaded petrol (UK)/ gas (USA)
Octane rating.....	at least E5 or RON 95
Capacity of fuel tank.....	11 L - 2.90 US gallons
Hydraulic fluid	Conforms to DIN 51524 Part 3 HVLP
Viscosity.....	ISO VG 46 cSt
Capacity of hydraulic system.....	10 L - 2.65 US gallons

References

SUNOCO.....	Sunvis 846 WR HV
ELF	Hydrelf DS 46
SHELL.....	Tellus TD 46
TOTAL.....	Equivis ZS 46
CASTROL	Anvol WG 46
TEXACO	Rando HDZ 46
MOBIL.....	DTE 15 M
ESSO.....	Univis N 46
Lubricant for bearings	NOVATIO CLEAR LUBE
Lubricant for pivot points.....	NOVATIO CLEAR LUBE
Lubricant for friction surfaces	NOVATIO PTFE OIL
Lubricant for chain transmission.....	NOVATIO CLEAR LUBE
Lubricant for grease fittings.....	MOBILGREASE XHP222

*The above information is only indicative. Please consult the manual provided by the engine manufacturer.

17.2. Torque chart

Bolt head according to DIN 931, 912	Thread	Strength	
		8.8	10.9
Normal thread	M4	3.0	4.4
	M5	5.9	8.7
	M6	10	15
	M8	25	36
	M10	49	72
	M12	85	125
	M14	135	200
	M16	210	310
	M18	300	430
	M20	425	610
	M22	580	820
	M24	730	1050
	M27	1100	1550
M30	1450	2100	
Fine thread	M8 x 1	27	35
	M10 x 1.25	52	69
	M12 x 1.5	89	130
	M14 x 1.5	145	215
	M16 x 1.5	225	330
	M18 x 1.5	340	485
	M20 x 1.5	475	680
	M22 x 1.5	630	900
	M24 x 2	800	1150
	M27 x 2	1150	1650
M30 x 2	1650	2350	

(friction factor \leftrightarrow = 0.14)

17.3. Error identification

The engine does not start: the engine does not run

- Battery voltage too low
- Service hatch not closed properly
- Blown fuse
- Blade shaft or turbine fan blocked
- Electrical circuit not properly protected

The engine does not start: the starter engages, but the engine does not start

- Lack of oil
- Lack of fuel
- Incorrect fuel
- Spark plug broken or faulty ignition
- Battery voltage too low
- Defective engine

Machine turns off while operating:

- Overload, shaft obstruction
- Lack of fuel
- Lack of oil
- Rear hatch not properly closed
- Engine defect
- Electrical circuit not properly protected

Loss of power / Diminished shredder performance

- Lack of fuel
- Fuel supply blocked
- Low-grade fuel
- Dirty air filter
- Blunt blades
- Blow chute or shredding chamber blocked
- Engine speed too low
- ABM sensor defect or malfunction
- Defect in the electrical system of the ABM system
- Solenoid valve problem (ABM)
- Battery voltage too low
- Carburettor failure
- Incorrect belt tension
- The feed roller does not go down to the lowest position.

The feed roller stops turning while the machine is operating:

- Safety button above the hopper has been pushed
- Safety bar around the hopper has been pushed
- The operating lever has been set back to the stop position
- Speed is too low
- Defective or malfunctioning ABM system
- Defect in the electrical system of the safety button
- Defect in the electrical system of the ABM system
- Solenoid valve problem (ABM)
- Broken drive chain

17.4. Troubleshooting

17.4.1. Blade shaft becomes blocked

- Switch off the machine.
- Open the shredding chamber.
- Completely empty the shredding chamber and make sure that no pieces of wood are wedged in the blade shaft. Check the turbine to make sure that no pieces of wood are wedged between the blades.



Caution: Wear protective gloves; the blades are extremely sharp!

17.4.2. Engine shuts off

- Turn off the engine.
- Check the engine oil; if necessary, top it off.
- If the oil level is okay, the problem could also be caused by an electrical defect.

17.4.3. Engine stalls

- Oil level too low.
- Out of gas.
- Electrical defect.

17.4.4. Starter does not react while starting engine

- The shredding chamber or the emergency safety bar are not where they should be.
- The battery is empty.
- Problem with the electrical system.
- Engine oil level is too low.

17.4.5. Capacity decreases

- Dirty air filter.
- Dirty fuel filter.
- Defective spark plug.
- Blunt blades.
- Incorrect tension of the trapezoidal belt.

17.4.6. Wheel drive does not function while petrol (UK)/ gas (USA) engine is running

- Safety bar is not in the neutral position.
- Defect in the electrical system.

17.4.7. Feed roller no longer functions

- Engine speed too low.
- ABM not working properly (contact your ELIET dealer).
- Problem in the hydraulic circuit (valve).
- Broken chain.

17.4.8. Engine shuts off and the machine must be moved - ZR model

- If the engine is not running, the rear wheels are no longer supplied with power.
- If you turn the control handle, you will still be able to move the machine slowly by pushing it.
- If the aforementioned suggestions do not work and the engine is no longer running because the blade shaft is blocked, we recommend that you take off the drive belts. This will free the blade shaft from the engine, and the engine can be restarted more easily.

18. Warranty conditions

Dear Customer,

We thank you for purchasing an ELIET product. Congratulations on your purchase of this machine, which is sure to far exceed your expectations over the coming years. At ELIET, we do everything in our power to ensure that our products function properly. That is why your product qualifies for a two-year warranty.

What is the warranty ?

The design and manufacturing processes for ELIET products are subject to very strict quality regulations. The purpose of these regulations is to guarantee a long service life and permanent safety. As such, ELIET will repair all faults and defects at no cost during the running-in period (the warranty period), so long as all instructions have been followed on your part.

Warranty conditions

ELIET's warranty obligation for new machines is governed by the following conditions.

I. Warranty period

The warranty period begins on the day the dealer delivers the machine to the customer (maximum one week after purchase) and expires:

- after two years of private use.
- after twelve months or 100 running hours of rental use.
- after twelve months or 100 running hours of semi-professional or professional use.

In order to benefit from this warranty, customers will have to register their purchased product with ELIET and complete the registration form on our website:

www.elieta.eu. If you do not have Internet access, please fill out the attached registration card and send it back to ELIET.

II. What is not covered by the warranty ?

- Wear items (blades, bearings, belts, chains, cogs, tyres, bulbs, fuses, etc.) are not covered by these warranty conditions.
- Defects due to improper use, negligence or external factors (falls, wood chips, foreign bodies, accidents).
- Defects due to a lack of performing machine maintenance in accordance with the prescribed periodic maintenance.
- Defects caused by improper repair work done by anyone other than an authorised ELIET dealer or after using non-original ELIET replacement parts.
- Defects caused following non-authorised modifications to the original machine design.
- Defects that arise from the machine not being used in accordance with the instructions contained in this manual.
- When the prescribed warranty procedure has not been adhered to or when the warranty period

has expired.

- For all problems relating to the engine, please contact a service centre that has been approved by the engine manufacturer.

III. Procedure

- **Step 1:** On the day of purchase, the customer will register their purchase online by completing the registration form at www.elieta.eu. Upon purchase, the customer will also fill in the attached registration card. The first part of the form must be sent back to ELIET within the month. The customer will keep the rest of the form, as well as the purchasing invoice, until the warranty period has expired.
- **Step 2:** In the event of a defect, the customer shall have it verified by their authorised ELIET dealer. If the dealer considers there to be a factory defect, the dealer may invoke the warranty under the terms specified.
- **Step 3:** Every warranty claim must be accompanied by a fully-completed official claim form. Dealers can obtain copies of this claim form from ELIET or from an ELIET importer/agent.
- **Step 4:** The dealer shall then order the replacement parts needed to perform the repairs. Next, the dealer faxes the order form, together with the completed warranty claim form and a copy of the registration card.
- **Step 5:** The warranty claim form must be stapled to the purchase invoice and mailed to ELIET or to an ELIET importer/agent.
- **Step 6:** ELIET will send the parts ordered to the dealer under the standard delivery and payment conditions.
- **Step 7:** The defective parts will first be examined by ELIET's technical department prior to the approval or rejection of a warranty claim. ELIET reserves the right to exclusively decide whether or not the customer has complied with the one- or two-year warranty conditions. Faulty parts shall automatically become the property of ELIET.
- **Step 8:** When a warranty claim is found to be valid, ELIET will credit the warranty parts. Labour costs for repairs are always to be paid by the customer.

IV. In case of damage during transport

- All goods are considered purchased as of the moment they leave the factory. Risks related to transport are to be borne entirely by the customer. ELIET highly recommends that the customer checks the goods for damage upon arrival.
- Any damage that has been noticed must be reported on the delivery invoice before it is signed. Make sure that the driver of the delivery company also signs this damage report on your copy of the invoice.
- The insurance company will not accept any liability if there is no written and signed declaration of damages on the delivery invoice.
- All claims for damages must be addressed to the delivery company, along with a copy of the delivery invoice and a letter detailing your complaint.
- The damaged machine must be kept in its original condition until the delivery company's insurer has conducted an examination.

REGISTRATIONCARD ELIET CUSTOMER SERVICE

To be able to claim the full rights to which you are entitled, it is important to register within a month after the date of purchase. Therefore fill out this registration form and return the first registrationcard to the ELIET Customer Service. Your purchase should be registered on the ELIET website: www.eliel.be

REGISTRATIEKAART ELIET KLANTDIENST

Om als klant, aanspraak te kunnen maken op waarborg dient men zich binnen de maand na aankoop bij ELIET te registreren. Hiervoor vult u onderstaand document volledig in en stuurt het eerste deel van deze registratiekaart naar de ELIET klantendienst terug. Registreer uw aankoop op de ELIET website: www.eliel.be

CARTE SERVICE

Pour profiter de tous les avantages dont vous êtes titulaire, il est important de vous inscrire dans le mois suivant l'achat. Complétez ce formulaire et renvoyez la première partie au Service Clientèle. Votre achat doit être enregistré sur le site Internet ELIET: www.eliel.be

ELIET

 Registration card
 Registratiekaart
 Carte d'enregistrement
 Registrationskarte

 ELIET Customer Service
 Zwevegenstraat 136
 B-8593 Otegem
 Belgium

Customer Identity / Klantgegevens / Données du Client / Kundendaten

Name / Naam / Nom / Name

First Name / Voornaam / Prénom / Vorname

Street / Straat / Rue / Strasse

Nr / Nr / N° / Nr

Box / Bus / Boîte / App.

City code / Postnr / Code Postal / Postleitzahl

City / Plaats / Ville / Stadt

Country / Land / Pays / Land

Telephone / Telefoon / Téléphone / Telefon-Nr.

Fax / Fax / Télécopieur / Fax

E-mail

Machine identity / Machinegegevens / Données de machine / Daten Maschine

Model / Model / Modèle / Modell

Year of manufacture / Boorjaar / L'année de construction / Baujahr

Article Code / Artikel code / Code d'article / Artikel-Nr.

Serialnumber / Seriennummer / Numero de série / Serien-Nr

Date / Datum / Date / Datum

 Signature
 Handtekening
 Signature
 Unterschrift

 Stamp of dealer
 Stempel van handelaar
 Cachet de revendeur
 Stempel Fachhändler

I declare that all information that was filled in is correct and truthful. I also declare to have read and understood the operations manual and the warranty conditions. Ik verklaar dat al deze gegevens waarheidsgetrouw werden ingevuld. Hierdoor geef ik te kennen de garantievoorwaarden en handleiding te hebben gelezen en begrepen. Je déclare que tous les données complétées sont correctes et véridiques. Je déclare également d'avoir lu et compris les notices du mode d'emploi et les conditions de garantie. Ich erkläre hiermit, dass alle angegebenen Daten korrekt und wahrheitsgemäß gemacht wurden. Ich erkläre ebenso, dass ich die Garantiebedingungen gelesen und verstanden habe.

Put a crossmark to which application this machine was used
 Zet een kruis bij de toepassing waarbij deze machine wordt ingezet
 Indiquez avec une croix l'environnement dans lequel la machine a été utilisée.
 Kreuzen Sie an, für welche Art von Gebrauch die Maschine bestimmt ist.

- Home use / Particulier gebruik / Usage particulier / Private Nutzung
 Professional Landscaping / Hoofmiersbedrijf / Usage Professionnel / Gewerbliche Nutzung
 Forestry / Bosbouw / Forêt / Forstbetrieb
 Public Groundscare / Openbare groenvoorziening / Espaces Verts Public / Öffentliche Grünflächenversorgung
 Rental / Verhuur / Location / Vermietung

Dit document dient binnen de maand na aankoop teruggestuurd te worden naar de ELIET Klantendienst.

This document has to be returned to ELIET Customer Service within a month after purchase.

Renvoyez ce document au Service après-vente ELIET dans le mois suivant à la date d'achat.

Dieses Dokument muss innerhalb eines Monats nach Kaufdatum an den ELIET Kundendienst zurückgeschickt werden.

