

ELLIET[®]

MANUAL

Prof 5



1. Introduction



1.1 Carefully read this user manual

Elite machines are designed for safe and reliable use if they are operated in accordance with the instructions given. Carefully read this user manual before using the machine. Failure to observe this may result in personal injury or damage to the equipment.

1.2 Identification data - Eliet Prof 5

Note the identification data relating to your machine in the boxed areas.

Product code :	<input type="text"/>
Serial Number :	<input type="text"/>
Year of Manufacture :	<input type="text"/>
Date of purchase :	<input type="text"/>

2. Warranty



2.1 Warranty card

To be eligible to obtain warranty you must mail the completed warranty card within one month of the date of purchase to the address stated below.

European customers :

ELIET EUROPE NV
 Diesveldstraat 2
 B - 8553 Otegem (Belgium)
T (+32)(0)56 77 70 88 - **F** (+32)(0)56 77 52 13
 www.eliets.be, e-mail: service@eliets.be

US customers :

ELIET USA Inc.
 3361 Stafford street (office B)
 15204 Pittsburgh (PA)
T 412 367 5185 - **F** 412 774 1970
 www.elietsmachines.com

Read the warranty conditions on the attached warranty card.

3. Welcome



Welcome to the family of ELIET customers.

We would like to thank you for the confidence that you have placed in ELIET and we are convinced that you have purchased the very best machine. The operating life of your ELIET machine depends to a great extent on how you care for your machine. This user manual and the engine manual provided will assist you in this respect. If you follow the instructions and suggestions in these manuals, your ELIET machine will operate for a very long time in optimal condition.

Read this instruction manual carefully before operating this machine. This will prevent you from operating the device incorrectly.

For your own safety, take into account the safety instructions stated in the relevant chapter. Even if you are thoroughly familiar with operating such equipment, it is still advisable to read these pages carefully.

At ELIET all our machines and devices are subjected to a policy of continuous change and therefore, the specification of your machine may differ slightly in terms of shape, technology and accessories. The descriptions and technical data in this manual are accurate at the time of printing. Certain illustrations and descriptions may not be applicable to your specific machine, but instead relate to a different version of the machine. In turn, we trust that you will understand that the texts and illustrations in this manual cannot lead to any claims.

If you still have any questions after you have read this manual, we request you to contact your ELIET dealer.

ELIET AT YOUR SERVICE

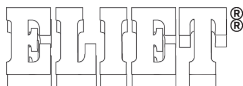

European customers :

ELIET EUROPE NV

Diesveldstraat 2

B - 8553 Otegem (Belgium)

T (+32)(0)56 77 70 88 - **F** (+32)(0)56 77 52 13

www.elieta.be, e-mail: service@elieta.be

US customers :

ELIET USA Inc.

3361 Stafford street (office B)

15204 Pittsburgh (PA)

T 412 367 5185 - **F** 412 774 1970

www.elieta.com

4. Table of Contents

1. Introduction	3
1.1 Carefully read this operating instruction manual	3
1.2 Identification data - ELIET Prof 5	3
2. Warranty	3
2.1 Warranty card	3
3. Welcome	4
4. Table of Contents	5
5. Safety symbols	7
5.1 For your information	7
5.2 Caution.....	7
5.3 Warning.....	7
6. Main parts	8
7. Safety regulations	11
7.1 Safety messages.....	11
7.2 Safety provisions.....	13
7.3 Safety regulations.....	15
7.3.1 General safety precautions	15
7.3.2 Careful and security-conscious use.....	15
7.3.3 Responsibilities of the operator	16
7.3.4 Personal protective equipment	16
7.3.5 Zone of danger	17
7.3.6 Periodic maintenance	18
7.3.7 Preserving nature	18
8. Dealer preparation	19
9. Operating instructions	21
9.1 Preliminary checks	21
9.2 Filling up with gas.....	21
9.3. Preparing the work area	22
9.4 Turning and positioning the blowchute and deflector flap	23
9.5 Starting the gas engine	23
9.6 Moving the machine	24
9.7 Operating the machine.....	25
9.7.1 Before starting work.....	25
9.7.2 Shredding proper	25
9.8 Troubleshooting.....	27
9.8.1 Rotor stalled	27
9.8.2 Engine cuts out.....	28
9.8.3 Engine stalls while running.....	28
9.8.4 Starter motor does not operate during starting (optional)	28
9.8.5 Capacity decreases.....	28
9.8.6 Wheel drive does not operate when gas engine is running.....	28

9.8.7 Feed roller no longer operates (optional).....	28
9.8.8 Engine no longer runs and the machine must be moved on ZR model.....	28
9.8 Cleaning the machine.....	29
10. Transporting the machine	30
11. Maintenance tasks described in detail.....	31
11.1 General.....	31
11.2 General interventions.....	32
11.2.1 Removing the belt guard	32
11.2.2 Disconnecting the battery.....	33
11.2.3 Opening the shredding chamber	33
11.3 Engine maintenance	34
11.3.1 Checking the oil level in the engine crankcase + refilling.....	34
11.3.2 Engine oil change.....	35
11.3.3 Changing or refilling the hydraulic oil	36
11.3.4 Changing the hydraulic oil and oil filter.....	36
11.3.5 Cleaning the air filter	36
11.3.6 Changing the air filter	37
11.3.7 Adding additional battery acid.....	37
11.4 Machine maintenance	38
11.4.1 Checking and sharpening the blades	38
11.4.2 Reversing and renewing the shredding blades	39
11.4.3 Checking the V-belt for correct tension	42
11.4.4 Tightening the V-belt	42
11.4.5 Checking and tightening the drive belt for correct tension	43
11.4.5 General lubrication	43
11.5 Maintenance schedule	46
11.5.1 Normal maintenance schedule	46
11.5.2 Special maintenance	46
11.5.3 Daily maintenance	47
11.5.4 Maintenance after 50 hours.....	47
11.5.5 Maintenance after 100 hours (or six-monthly).....	47
11.5.6 Maintenance after 200 hours (or annually)	48
12. Winterizing the machine.....	49
13. Equipment specifications	50
14. Prof 5 PTO.....	54
15. EC Declaration of Conformity	56
16. Warranty-conditions.....	57
17. Hazard analysis	60

5. Safety symbols



Certain symbols in this manual are used to provide additional information and to draw your attention to potential risks.

5.1 For your information



For your information

This symbol is used to draw your attention to specific information and/or actions, or to denote where you can find additional information relating to the subject.

5.2 Caution



Caution :

This notice identifies safe usage habits. This is done to prevent incorrect actions that can result in personal injury or damage to the machine.

5.3 Warning



Warning :

This notice is used to warn you about extreme danger that you must be aware of in these specific circumstances. Thus remain alert, in order to ensure your own safety.

6. Main parts

To fully understand the content of this operator's manual, you need to be fully conversant with the terminology used for the descriptions. In this chapter you can find a set of parts identified by name. It is a good idea to take time to study the machine beforehand for an improved understanding of the descriptions provided in this user manual.

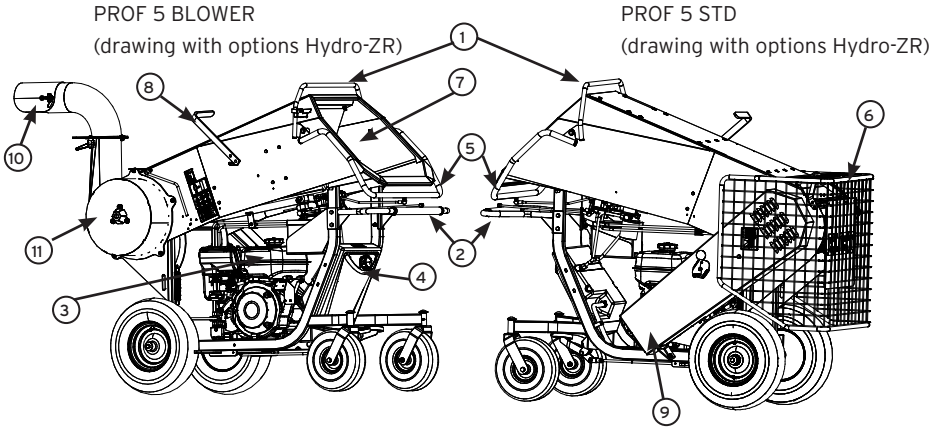

- | | |
|---|----------------------------|
| 1) Safety handle | 7) Loading hopper |
| 2) Wheel drive control / steering wheel (option ZR) | 8) Controller feed roller |
| 3) Gas tank | 9) Belt cover transmission |
| 4) Hydraulic oil tank | 10) Blow chute |
| 5) Feed control (option Hydro) | 11) Turbine blower |
| 6) Protection guard | |

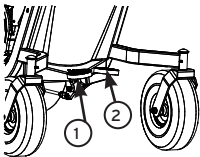

- 1) Parking brake
- 2) Pedal clutch

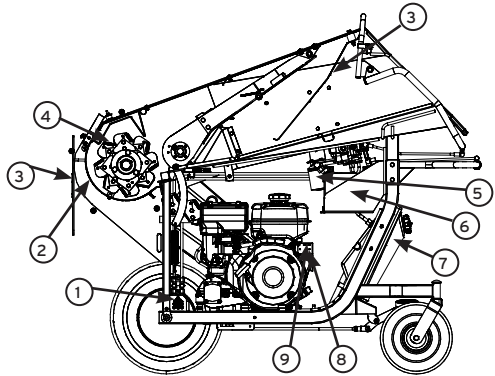

- | | |
|-----------------------------------|---------------------------------|
| 1) Hydraulic wheel motor (option) | 5) Hydraulic oil filter |
| 2) Grating (on STD version) | 6) Battery |
| 3) Safety screen (on STD version) | 7) Hydraulic oil reservoir |
| 4) shredding chamber | 8) hours run counter (option) |
| | 9) ABM indicator light (option) |

Engines:

14 HP Subaru EX40

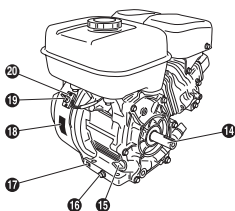
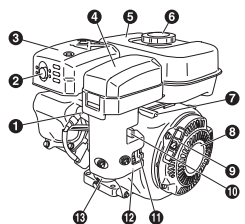

- | | |
|--|----------------------------|
| 1) Spark plug | 11) Fuel lever |
| 2) Exhaust outlet (elongated on machine) | 12) Fuel Cup |
| 3) Muffler cover | 13) Carburetor |
| 4) Air cleaner | 14) PTO shaft |
| 5) Fuel tank | 15) Oil gauge (oil filler) |
| 6) Fuel tank cap (fuel filler) | 16) Oil drain plug |
| 7) Speed control | 17) Engine serial number |
| 8) Lever Recoil starter | 18) Engine name label |
| 9) Starter handle | 19) Stop switch |
| 10) Choke lever | 20) Oil sensor unit |

13 HP Honda GX390

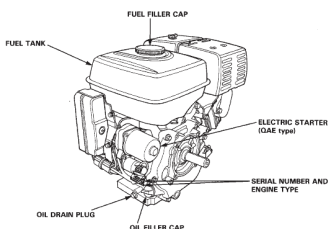
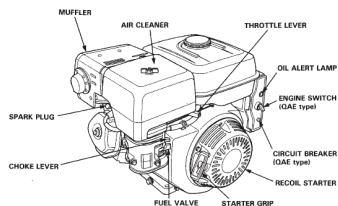
**For your information :**

Reference in this manual to right or left hand side, back or front of the unit is observed from the machine operator facing the branch feed of the machine.

Your ELIET dealer is at your service, ready to provide you with maintenance or advice so that your ELIET machine always remains in optimal condition. You can contact him for genuine ELIET service parts and lubricants. These service parts are manufactured to the same stringent accuracy requirements and standard of craftsmanship as the original equipment.



Caution :

For your safety, use only genuine ELIET parts on ELIET machines.

7. Safety regulations



7.1 Safety messages



For your information :

Safety stickers have been affixed on to visible areas of the machine. Make a note of the warning messages specified on these stickers.



This sticker is attached to the safety net and warns against the danger of injury to hands. The screen on the shredding chamber should only be opened once the blades have come to a complete standstill. The motor should always be switched off before lifting the safety net.



This sticker is attached to the drive belt guard. The sticker points out the danger which can occur if the guard is removed while the motor is rotating. Never operate the machine if the guard is not in place.

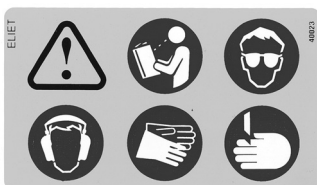

This sticker is attached to the side of the machine. It provides a summary of the general safety regulations by using icons:

1. Before operating the machines the manual should be read and understood.
2. Suitable safety clothing (gloves, safety glasses, ear defenders) should be worn when operating the machine.
3. Operating or carrying out maintenance on the machine presents the risk of injury to hands. Be alert and careful.



This sticker is attached to the machine at engine height. This sticker reminds the operator to switch off the engine and release the spark plug cap before carrying out maintenance on the machine.



This sticker is attached in the input opening. The sticker emphatically points out the risk of injury to hands which is inherent in wood shredding. The sticker reminds the operator how to operate the shredder in the safest possible way. It is prohibited to insert your hands beyond the safety shield!



This decal is located on the side of the loading hopper. It lists all the identification data relating to the machine :

Model, model number, serial number, year of manufacture, engine, power rating, weight, guaranteed A-weighted sound power level Lw(A).

This sticker also lists the manufacturer's details. The CE label means that the machine complies with the governing European machinery directive.



Caution :

Safety stickers becoming damaged, illegible or removed through use or cleaning, must be immediately renewed. Stickers are available at your approved ELIET Dealer.

7.2 Safety provisions

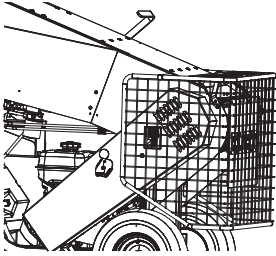

Safety screen (on STD version)

The safety screen (1) avoids access to the blades. No tools are required to open the screen, but the motor is shut off on opening the screen. The motor can be turned on again once the screen is closed, that is, when the safety limit switch (2) is actuated.

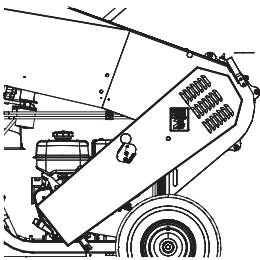

Belt guards

These guards provide protection from the moving belt. These guards can only be removed using tools. The machine must not be started if these guards are not correctly fitted.

Rugged construction :

The robust construction not only adds to the long operating life of the machine, but also provides additional user safety whenever there is an unforeseen emergency.

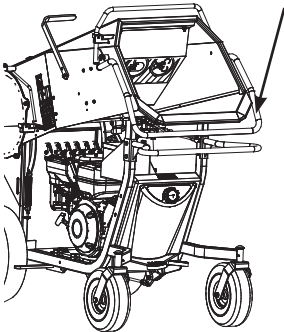

Safety handle (on Hydro version) :

You can operate the feed of the machine with this control lever.

Operating positions of the safety handle

All versions:

- 1: out
- 2: stop
- 3: in

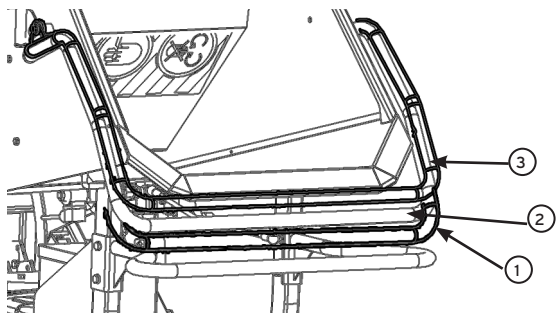

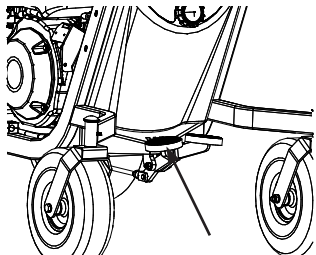
**Parking brake :**

The parking brake will lock the machine in its position whilst working or transporting material. This ensures that there cannot be any unforeseen situations where the machine starts to move unintentionally.

**Safety wear :**

For your safety, we strongly recommend to use the safety kit supplied as standard. It contains your Personal Protective Equipment (PPE). This safety set consists of safety glasses, ear plugs or hearing protection and a pair of riggers gloves.

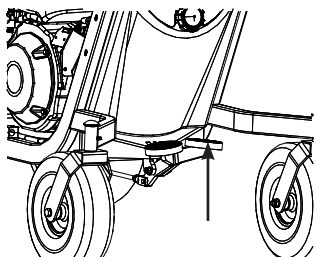
**Rotor and turbine brake :**

If you have chosen the ZR option a brake is installed on the machine. This brake makes sure the blades don't turn and the blower doesn't blow when the engine runs. You can transport your machine without problems.

7.3 Safety regulations

7.3.1 General safety precautions

- The Owner Manual must stay with the unit during its complete service life. It serves as a reference for the user, and enables the machine to be used and maintained in accordance with the correct instructions. Always refer to this instruction manual if you have any doubts about an action that you are about to perform.
- If the instructions stated in this manual are not clear to you, do not hesitate to contact your Eliet dealer for further explanation. ELIET's helpdesk (+32 (0)56 777088) is also at your disposal during office hours to provide answers for your questions.
- Read the chapter that is meant for the dealer (see Chapter 8) and immediately check whether or not the machine has been delivered in accordance with the instructions.
- Carefully observe all safety instructions when using the ELIET machine ! Carefully read all the instructions relating to the use of the machine. All these instructions relate to your personal safety.
- When you purchase the machine, first allow the dealer or a professional to give you some instruction.
- Read and observe all safety messages posted on the machine in the form of stickers.
- Read and observe all safety messages posted on the motor.
- Under no conditions whatsoever may the original design of the machine be modified without written consent of ELIET.
- Under no circumstances must a safety item be shunted, disassembled or switched off.
- As shredding involves ongoing considerable physical effort, take regular breaks for food intake, rest and drinking.
- It is unsafe for persons suffering heart problems and/or having balance disturbances to operate the machine.
- Avoid inhaling the exhaust fumes from the machine. Exhaust gases contain toxic particles which could prove fatal. Never start the engine in an enclosed area.

7.3.2 Careful and security-conscious use

- This machine is designed solely for shredding branchy material, prunings, leaves and all kinds of organic garden debris. Any use other than the designated operation is at the risk and responsibility of the operator.
- Never attempt to shred branches that are frozen.
- Think about what you are doing whenever you operate the machine. Do not be tempted to let routine dull your attention. Never act impulsively or in reflex.
- Despite the extensive safety features, do not seek out dangerous situations.
- Take care to preclude any tools falling into the in-feed funnel.
- Be aware that the machine ejects the shredded material through the blowchute. Make no one or nothing is in the area where the blowchute is directed.
- Do not feed foreign materials. (string, stones, metal, plastic, textile, etc.)
- According to the manufacturer, this model will take branches up to 80 mm diameter. For your

own safety on no account should any attempt be made to introduce stems thicker than the stated capacity.

- The machine is not designed to be subjected to the stated maximum capacity for longer periods. As a guideline: no more than 10 % of the garden waste that is to be fed into the machine may have a diameter in excess of 90 mm.
- Never stand on a step when feeding garden waste into the loading hopper.
- Do not use a fork or a shovel to or a fork to feed the machine with garden waste.
- Do not use your feet to feed garden waste in the loading hopper.
- Never work in conditions where light intensity is less than 500 Lux.
- Always remember to set the parking handle, so as to prevent the machine from moving.
- For deontological reasons, ELIET accept no responsibility whatsoever for any accidental injury to pets or persons caused by its machines.

7.3.3 Responsibilities of the Operator

- All persons using the machine are assumed to be fully conversant with the safety instructions.
- The operator is fully liable for the use of the machine in regard to himself and to third parties.
- Operators are presumed to possess a certain level of maturity that permits them to make decisions based on common sense.
- Underage persons must not operate the machine. However, this does not apply to youths above the age of 16 years, who are learning to operate the machine under the supervision of an experienced operator.
- A disabled person may only operate the machine when under the supervision of an experienced operator.
- Children and animals must be kept well away from the machine.
- ELIET recommend that the machine should not be lent to others. However, if this is done, only lend it to persons who are conversant with the machine.

Always ensure that the user is aware of the potential hazards and ensure that he reads the manual before he uses the machine.

(an indicative list of potential hazards can be found at Appendix)

- This machine must only be operated by persons who are in good physical condition. If you become tired during the work, take a rest in due time. Persons consuming alcohol or drugs must not operate this machine.

7.3.4 Personal Protective Equipment (PPE)

- You must wear suitable clothing to operate this machine. That is, clothing covering the whole body, heavy protective gloves and closed nonslip footwear.
- Do not wear loose fitting clothing (a shawl, for instance, should be avoided by all means). Long hair should be contained using a cap or a headband, or worn in a ponytail.
- For the protection of the most sensitive senses, ELIET recommends ear hearing protection and safety goggles.

- Shredding may result in dust production. If this dust irritates your lungs, we recommend that you wear a dust mask conform to directive 89/686/EC.

7.3.5 Zone of danger

Graphical representation of the zone of danger

STD:

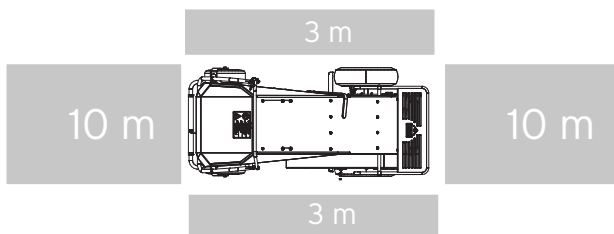

BLOWER:

The blower can be turned in different positions. The danger zone shifts in the manner the blower is turned.

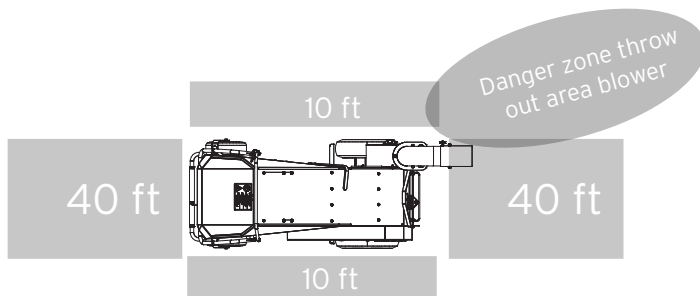

- During the work, do not allow bystanders to enter the zone of danger that stretches up to 40ft around the machine. Do not take any risks and immediately stop the machine as soon as anyone enters the danger area.
- Always let the machine run empty before switching of the engine. Left over chippers in the chipper chamber can block the blades or turbine so that the machine does not start.
- When leaving the machine, the engine must be switched off. Always wait until the blades come to a complete standstill before carrying out any operation. Once the engine is running, focus all your attention on operating the machine.

7.3.6 Periodic maintenance

- Periodic maintenance is essential. For this reason, strictly follow the maintenance schedule in this user manual (see Chapter 11).
- A maintenance counter will help you keep track of the hours run (optional).
- When replacing parts as a result of wear or failure, always request genuine ELIET service parts from your ELIET dealer. This is important in the interests of your own safety.
- Always make sure the engine is switched off and the battery cables disconnected before performing repairs or maintenance.



For your information

Also, read the engine manual that comes supplied with the machine. This contains the information required for the correct use and maintenance of the engine.

- Also read the engine manual, in order to carry out all maintenance according to the safety rules given by the engine make.

7.3.7 Preserving Nature

Use the machine in a manner that respects environmental regulations.

- Avoid unnecessary machine running while not at work.
- Avoid spilling gas while refuelling.
- Service the engine regularly in order to achieve optimum combustion.
- Prevent battery acid from overflowing.

8. Dealer preparation

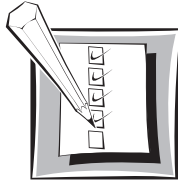

Warning :



As an ELIET dealer you **must** familiarize your customers with the **functioning of the machine** and also **point out the possible dangers** while using it. You are expected to carefully go over the maintenance points of the machine together with the new owner. Repeat these instructions until the new owner has fully understood everything.



Warning :

The manufacturer, ELIET wish to re-emphasise that the Dealer must expressly point out to the customers that they must examine the bolts which retain the chipping blades for security of fixings **within the first 5 operating hours**.

Ignoring this operation may cause serious injury and may even lead to death. In addition to damaging the machine, the client shall lose all entitlement to make a claim on the warranty. See the list with tightening torques in the annex.

- Likewise, make sure to check the belt for correct belt tension after a run-in period of 10 hours.
- Each machine that leaves the factory contains a limited amount of oil and fuel. The dealer must check the levels of the oil and fuel and top them up in accordance with the instructions in this manual (or in the engine manual).
- The Dealer performs a test run on the machine and confirms that everything is functioning properly (such as the safety contact at the collection bag).
- He also checks that the bolts securing the blades are fully tight.
- Lastly, the dealer makes sure that the warranty card is filled in completely and signed. This, in order to avoid any warranty disputes. For more information, please read the warranty conditions on the warranty card.

- ELIET machines are packaged in accordance with common rules that apply for such transportation. Deliveries will always be ex factory. ELIET cannot, therefore, be held liable for damages that occur during transportation.
- Should you notice damage to the packaging when goods are accepted, always check the state of the machine to ensure it is not damaged. Report any deviation on the delivery order before signing off for receipt.
- Should the machine be damaged, you should always immediately submit a complaint to the shipping company.

9. Operating instructions

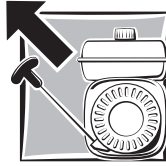

9.1 Preliminary checks



Caution :

Before starting to shred, always run through the checklist below.

Checklist

1. Check the oil level of the machine.
2. Ensure there is enough gas in the tank. If necessary, fill up the tank with gas.
3. Check whether the air filter is not too dirty.
4. Satisfy yourself that the shredding blades are firmly in place and in good condition.
If they need to be sharpened, this must be done first.
If one detects cracks or fractures in a blade, this blade must be immediately renewed.
For safety's sake, tighten the blade bolts.
5. Check whether all safety provisions on the machine still operate.
6. Check whether no chippers are left in the chipper chamber, nor in the turbine. These can block the engine before starting.

Once these items have been checked and approved, you can prepare the area of operation (see Chapter 9.3) and move the machine to the work site.

9.2 Filling up with gas

Top up if the machine runs short of gas. It's a good idea to only use fresh gas (see Appendix A). Use lead-free gas, preferably 98 or 99 octane. Any other fuels are prohibited. (read the engine manual).



Warning :

Under certain conditions, gas is highly flammable and extremely explosive. Fire and explosion caused by gas can result in serious burns or damage to property.

- Do not add fuel while engine is running. Always allow a few minutes for the engine to cool off before topping up with fuel.
- Only use fresh gas.
- Never add oil to fuel.
- Because of the short shelf life of fuel, it is good practice to buy fuel in small quantities.
- Store gas in an approved container. Keep this container out of the reach of children.
- Store fuel in a well-ventilated area away from open flames, sparks and heat sources.
- Never top up fuel at a location where work is to be performed later. Always keep all persons at least 10 m away from the work area. This is done to prevent any fires from occurring.
- Clean the area around the fuel tank cap and then remove this cap. Never fill a tank to over 85% of the tank's capacity. Top up with fuel until the level is approximately 20 mm from the top of the tank. In short, do not fill the tank completely to the tank filler opening.
- Always use a funnel or spout to pour the gas into the tank. Suitable funnels can be obtained from your ELIET dealer.
- Refit the cap onto the tank as soon as possible.
- Be careful not to spill gas onto clothing. If gas does come into contact with your clothing, change this clothing at once.
- It is unsafe and thus expressly forbidden to fill the fuel tank in the vicinity of smokers or naked flames.
- If fuel comes into contact with the eyes or is taken internally, obtain medical attention immediately.

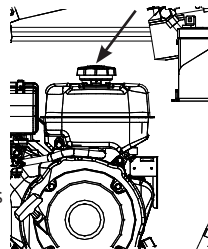

Caution :

Be carefull not to fill the fuel in to the hydraulic reservoir!

9.3 Preparing the work area

- Clear the area first where the machine is to be used. In addition, the paths along which the plant trimmings are removed, must be kept clear, thus releasing the operator from the worries of tripping up over them. The operator must also ensure that his safety is not compromised.
- Make sure to locate the machine such that flying chippings expelled from the discharge output do not cause damage to persons or properties.
- On slopes, never operate the machine (no forward, backward or lateral slope).
- Make sure to sort the material beforehand. In this way, the operator is sure that no foreign objects will enter the machine with the material.
- Foreign objects are defined as: any non-organic object or branchy material in excess of the stated capacity (such as metal, stone, plastic, pvc, cords,...). Some of these can cause serious damage to your machine or can be ejected, virtually as projectiles towards the user.
- Always position the machine so that the wind will blow the dust produced away from the engine.

9.4 Turning and positioning the blowchute and deflector-flap

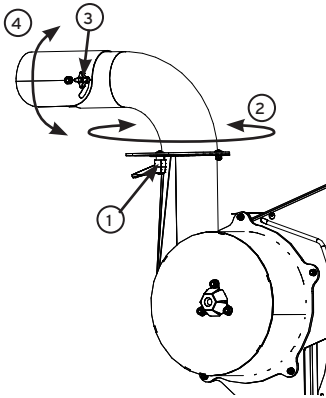

The blowchute can be turned into various positions. In order to do this follow these instructions:

1. Loosen the handle (1).
2. Place the blowchute (2) in the chosen position.
3. Fasten the handle (1).

The directional deflector flap can be turned up and down. In order to do this follow these instructions:

1. Loosen the nut (3).
2. Place the deflector flap (4) in the wanted position.
3. Fasten the nut (3).

9.5 Starting the Gas Engine



Caution :

Never start the machine if the engine cooling fins are not clean and free of debris to protect it from overheating.



For your information :

Also, read the engine manual.



Warning :

Never run the engine indoors. Exhaust gases contain toxic substances and may lead to intoxication or suffocation.

Before starting the engine, check whether adequate oil and fuel is present in the engine.



Warning :

Before starting up the machine, make sure to wear the ear defenders supplied as standard.

- Ensure the shredding chamber and turbine are empty. This is to avoid starter mechanism overloading.
- Be sure the shredder hopper is empty (no tools...).
- Make sure the safety grid is closed and the safety switch is actuated. If not, the machine cannot be started. (STD version)
- Start the engine.
- At ELIET, we recommend to keep maximum engine speed at 3,200 rpm. Never make any alterations to this factory-set maximum speed setting.

9.6 Moving the machine

A. If you either have a standard machine

As the machine is not self-propelled, it is pushed or pulled to the work site with the engine turned off.



Warning :

the machine is a heavy piece of equipment. Know your own capability. Overuse of your back may cause prolonged pains, rheumatics and paralysis. Always seek assistance when lifting things that are too heavy for you.

B. If you have a self-propelled machine (ZR type)

- Start the engine (Chapter 9.4).
- Make sure that the safety handle is in the neutral position.
- Make sure the rotor brake is put in the upper position, so that the blades and turbine doesn't operate.
- Moving the machine:

Move the control handle forwards, then the machine will move forwards.

The more you move the control handle forwards, the faster the speed. The opposite also works: Turning the control handle backwards will cause the machine to move backwards at a speed proportional to the amount that you move the control handle.

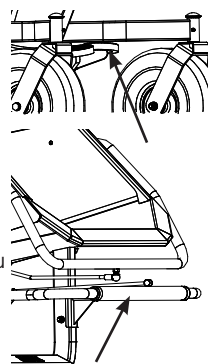

TIP :

It is a good idea to become acquainted with the characteristics of a self-propelled machine and do so in a quiet spacious location without bystanders.

9.7 Operating the machine

9.7.1 Before starting work

- Wear proper apparel, protective gloves and safety equipment as instructed in this manual (see Chapter 7.3).
- A good gardener is well organized and plans his work. This will enable you to have perfect control to avoid accidents.
- The wood should be systematically stacked before commencing the work : thick branches, thin branches, leaves and damp products. Ensure that the material does not contain any foreign objects.
- Never run the machine in an enclosed area. If this is done, there is a danger of being poisoned by the exhaust fumes from the engine.
- Always shred with the engine at full throttle.



Caution :

If you do not have the ZR-option, once the engine is running, the shredding blades are rotating, therefore, irrevocably shredding anything that is introduced into the loading hopper.

9.7.2 Shredding proper

- Be careful when performing work.
- While operating the machine, focus your concentration completely on the work.
- Drive the machine to the work site.
 - Start the engine.
 - Allow the machine to run idle for about 5 minutes.



Warning :

Remember : When shredding at temperatures around freezing, maximum branch size of branchy material is limited to 60 mm.

- HYDRO: Move the control lever to the infeed position. The feed roller starts to turn and pulls the garden waste into the loading hopper at a constant speed. The maximum lift of the feed roller is 105 mm.
- Preferably, the operator's position is next to the black loading hopper to introduce the garden waste. In this way, flying chippings finding their way from below the safety screen that are expelled from the in-feed do not cause personal injury.
- If you have the blower version, feed the garden waste into the loading hopper on the right side of the hopper. This makes that the chippers stay longer in the chipper chambre so that the chippers are smaller.

- Feed the garden waste into the loading hopper and guide it towards the feed roller. In the case of loose garden waste (leaves, etc.), use a branch to push the material up to the feed roller. (DO NOT USE a shovel or a fork to do this).
- Never use a step for feeding the loading hopper with garden waste.
- No attempt should be made to use your feet to push garden waste in the loading hopper.



Warning :

Do not lean forwards to push material further into the loading hopper so that your hands NEVER go past the safety screen.

- By reducing the amount of material that you feed into the machine, it will operate more optimally.
- In the case of branches, it is recommended to feed in the thickest part of the branch first.
- It is preferable to feed thick branches into the left-hand side of the loading hopper on the STD version, and into the right hand side of the loading hopper on the blower version.

• You can determine the feeding-in speed as follows:

- Without ABM: You listen to the sound of the engine: if you hear that the engine speed decreases substantially, this indicates that the engine is encountering problems (speed decreases below 2500 rev./min.). If this happens, stop the material from being fed in by moving the control handle into the stop position. When the engine returns to its normal speed, you can restart the feed roller by moving the control handle to the infeed position.
- With ABM: The feed roller stops when engine speed is too low (< 2750 rpm) ; the warning light (1) lights up. When the engine returns to its normal speed, restart the feed roller.

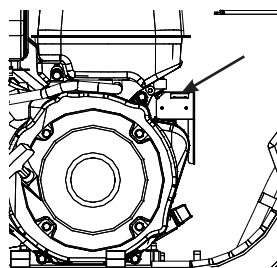

- If the amount of chippings block off the output opening, move the machine backwards. The pile may not be higher than the bottom of the rear flap.

Not on blower model: With moist materials, it is best to use a sieve for damp products.
(Order number : MA 026 001 001)

- If the shredding chamber gets clogged up, switch off the machine to remove the blockage. Make sure to wait for the blades to come to a complete standstill, before carrying out any operation on the machine. For safety's sake, disconnect the spark plug wire.

**Warning :**

In order to avoid personal serious injury or damage to properties, never operate the machine without a sieve screen fitted.

- If you notice a foreign object in the garden waste in the loading hopper, perform the following steps:
 - Stop the feed roller by pushing the control handle to the stop position.
 - Stop the engine.
 - Remove any foreign objects.
- If you notice a strange noise during the work, immediately stop shredding. Stop the engine and investigate the cause of the defect. Before proceeding, perform the necessary repairs.

9.8 Troubleshooting

9.8.1 Rotor stalls

STD:

- Switch off the machine.
- Open the shredding chamber.
- Completely empty the shredding chamber and make sure that no pieces of wood are wedged in the blade drum. If, despite this, the blade drum is still jammed, this indicates a mechanical problem (e.g. a bearing that has seized, etc.).

BLOWER:

- Switch off the machine.
- Open the shredding chamber.
- Completely empty the shredding chamber and make sure that no pieces of wood are wedged in the blade drum, check the turbine if there is no wood wedged between the sides and the propellor.

**Caution :**

Wear protective gloves as the blades are razor sharp !

9.8.2 Engine cuts out

- Stop the engine.
- Check the engine oil; if necessary, top it off.
- If the oil level is OK, this problem could also be caused by an electrical defect.

9.8.3 Engine stalls while running

- Oil low-level fault.
- Out of gas.
- Electrical defect

9.8.4 Starter motor does not operate during starting (optional)

- Safety guard is open.
- Battery is in a low state of charge.
- Defect in electric circuits
- Engine oil low-level fault.

9.8.5 Capacity decreases

- Dirty air filter.
- Fuel filter in need of cleaning.
- Dirty or fouled spark plug.
- Blades are blunt.
- Incorrect tension of V-belt.

9.8.6 Wheel drive does not operate when gas engine is running (optional)

- Safety handle is not in neutral position.
- Defect in the hydraulic circuit.

9.8.7 Feed roller no longer operates (optional)

- Engine speed too low.
- ABM in disorder (Contact your ELIET dealer).
- Problem in the hydraulic circuit (valve).
- Chain broken.

9.8.8 Engine no longer runs and the machine must be moved on ZR model

If the engine is not running, the rear wheels are no longer driven.

- If you turn the control handle on the steering, you are still able to slowly move the machine (using the force of the operator).
- If this is not possible, and the engine no longer runs due to a blocked rotor, you may wish to

take off the drive belts. This ensures that the rotor is no longer driven and that the engine can be restarted.

9.8 Cleaning the machine

It is strongly recommended that you clean the machine after each use. Failure to do so will :

- Lead to premature wear of the bearings, gaskets and drive belts.
- Increase the risk of fire.
- Decrease the cooling efficiency of the engine.
- Inability to detect fractures or cracks.
- Have a detrimental effect on the paint coating and the safety stickers.



Warning :

A machine that is no longer in good working condition may compromise the security of the user.



Caution :

Wear suitable clothing when cleaning.
Gloves are required.

- Use a dry cloth, a soft brush, etc. for cleaning. To remove grease and lubricants, use penetrating oil containing molybdenum disulphide. This spray lubricates and also dissolves rust.
- It is useful to have compressed air in the vicinity so that you can use it to clean various components.
- Pay special attention to cleaning the engine. In particular, the cooling fins and air inlet must be thoroughly cleaned in order to guarantee optimal cooling of the engine.
- Pressure-washing of the machine is permitted. However, never point the water jet for long periods in the direction of bearings, electrical contacts or filler caps. Water is known to be the main cause of corrosion and must, therefore, be avoided at all times.
- A washing out of the lubricant is possible ; for this reason, plan a lubrication task after thorough cleaning.
- The engine manufacturer does not recommend water cleaning.

10. Transporting the machine



- Make sure to clear the shredding chamber and turbine (on blower model) before moving the machine. Make sure the infeed opening is free of branchy material.
 - The maximum allowable lateral slope angle amounts to 10%.
 - Use slip resistant ramps to load the machine into a van or a trailer. Make sure that they are securely attached to the vehicle or trailer.
 - Under no circumstances must the angle of the up and/or down ramp be greater than 20%.
 - Be careful and composed when loading and unloading the shredder so that the machine does not tip over and give rise to an accident.
 - When coming down the ramp, move down backwards facing the machine.
 - If gravity causes the machine to descend more quickly down the slope than is desired, quickly move the control handle to the other drive direction. This enables you to hydraulically brake the machine.
-
- Make sure to properly secure the machine to the vehicle during transportation. Use the fixed parts of the vehicle frame to attach ropes. Attachment points (1) are provided for securing ropes. Always be sure to use the parking brake (2).
-
- Do not forget that the machine has a high centre-of-gravity. Therefore use ropes to secure both sides of the machine to the vehicle. This ensures that the machine is not toppled over when the vehicle goes around a bend.
-
- Do not overload the vehicle.

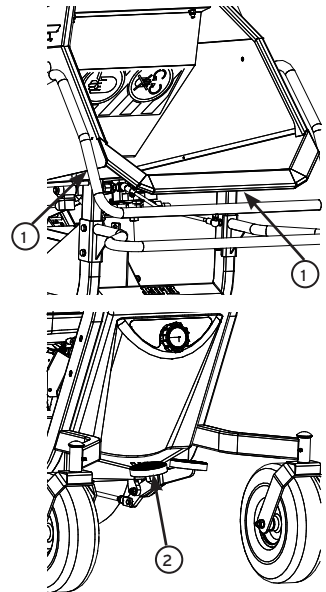

11. Maintenance tasks described in detail

11.1 General



For your information :

The dealer's personnel are always at your service. The ELIET dealer can always rely on comprehensive support from ELIET NV, so that we can work together to find a solution for any problem that you may have. For a repair or for the maintenance of the engine, you can always contact your ELIET dealer or a maintenance service that is recognized by the engine manufacturer. If you need to contact these services, please provide us with the Model Number and Serial Number of both the machine and the engine, and also describe the problem in detail.



Caution :

Only use genuine ELIET replacement parts. These service parts are manufactured to the same strict quality control requirements and degree of craftsmanship as the original equipment.

For your safety, use only genuine ELIET parts on ELIET machines.

Perform maintenance in a room intended for this purpose. This room must be

- Spacious
- Well lit
- Clean and tidy
- Easily accessible
- Dust-free
- Quiet

These characteristics are important to enable maintenance to be performed in an optimal manner.



Caution :

Improper maintenance may subsequently compromise the safety of the operator.

Prior to doing service operations, first make sure to disconnect the battery cables. (Disconnect the + terminal)

When performing maintenance, always wear gloves, and also safety glasses for some operations. Those are included with the machine.

TIP :

The maintenance work described can essentially be performed by any person who possesses the requisite technical knowledge. However, ELIET recommend that the machine should be handed in to an ELIET dealer for a Prof 5 overhaul each year.

Your ELIET dealer is always at your service for maintenance and advice. He stocks genuine ELIET service parts and lubricants. His staff can always obtain advice and service from ELIET, so that they can provide you with an impeccable after-sales service.

11.2 General interventions

**Warning :**

For your own safety: After performing the maintenance, refit ALL guards.

NEVER OPERATE THE MACHINE WITHOUT SAFETY GUARDS !

11.2.1 Removing the belt guard

- Ease the safety guard (1) sideways. (on the STD version)
- Remove bolt the 2 bolts (2) (M8)
- Remove bolt the 3 bolts on the upper side and the 2 bolts on the lower side (3) (M6)
- Remove the guard.

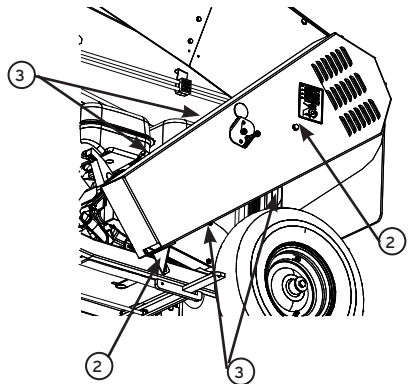
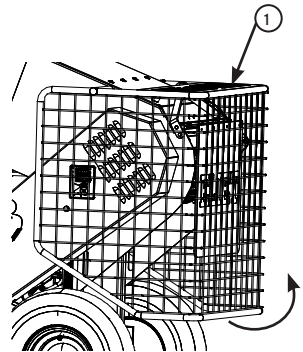

11.2.2 Disconnecting the battery

- Disconnect the negative terminal (black M6, SW 10).
- Disconnect the positive terminal (red M6, SW 10)

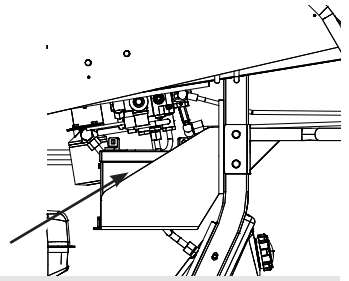

Caution :

First connect the positive terminal (2) (red M6, SW 10).
And then the negative terminal (1) (black M6, SW 10).

11.2.3 Opening the shredding chamber

STD VERSION:

- Ease the safety guard (1) upwards
- Pull the lock (2) downwards.
- Make sure that both clamps (3) are released.
- Topple the shredding screen (4) downward.

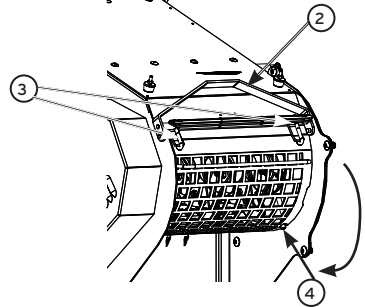
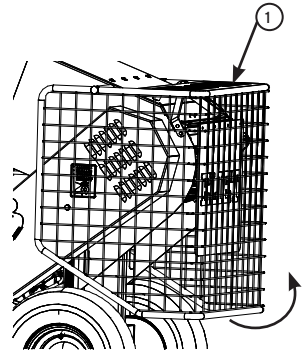

Caution :

The shredding screen is hooked into the backside of the machine. When the clamps are released, pay attention that the screen does not fall and gets damaged.

BLOWER VERSION:

- Pull the lock (1) downwards.
- Make sure that both clamps (2) are released.
- Topple the shredding screen (3) downward.

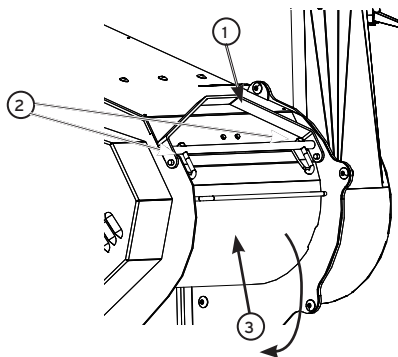
**Caution :**

The screen is hooked into the backside of the machine. When the clamps are released, pay attention that the screen does not fall and gets damaged.

11.3 Engine maintenance

**Warning :**

When running, engines emit carbon dioxide: an odourless and colourless poisonous gas. Inhaling carbon dioxide can cause nausea, fainting or death.

Start the engine outside.

NEVER run the gas engine powered machine in an enclosed area, even with the windows and doors open.

11.3.1 Checking the oil level in the engine crankcase + refilling

Inadequate oil in the engine will cause irrevocable damage to the engine. Therefore, regularly check the oil level as follows.

- Park the machine on a level surface so that the engine is perfectly horizontal.
- Switch off the engine.
- Take a clean cloth.
- Remove the dipstick and use a cloth to wipe it clean (the oil level shown on the dipstick is not always correct the first time that the dipstick is removed). Therefore reinsert the dipstick and then remove it again. The oil level must reach the "F"(Full) mark on the dipstick.
- If not, top off (Note : do not overfill).
- First clean the area around the filler cap before topping up the oil.
- Remove the filler cap and remove the dipstick so that the crankcase is ventilated.

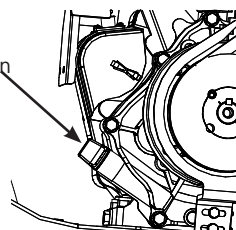

**Caution :**

Topping off the oil level is a meticulous job :
do not overfill the reservoir
to extend engine life and maximize engine performance.

- Gently replenish the oil reservoir. Regularly check the oil level on the dipstick (to see when the desired level has been reached).
- Only use the recommended oil (see manual engine).
- Once the crankcase is replenished with the correct oil, place the check plug back in position and securely retighten the oil filler cap.
- Immediately clean away any spilled oil.

**Caution :**

Make sure that no dirt enters the crankcase via the filler cap.

11.3.2 Engine oil change

**Warning :**

Filling the engine with oil is performed in TWO steps:
Read all of the text carefully!

- Make sure that the engine is horizontal.
- Allow the engine to run until it reaches normal operating temperature, then switch off the engine.
- Hold a receptacle (capacity 1,1 l) underneath the oil drain plug.
- Open the fill cap
- Open the sump plug and allow the contents to drain into the receptacle.
- Refit the oil drain plug.
- Partially fill the engine with 0,8L of fresh oil and refit the filler cap.
- Start the engine and allow it to idle for 20 seconds.
- Stop the engine and wait for 30 seconds.
- Then gradually fill the engine with the rest of the oil until it reaches the "F"(Full) mark on the dipstick. (total capacity 1l)
- Immediately clean away any spilt oil.

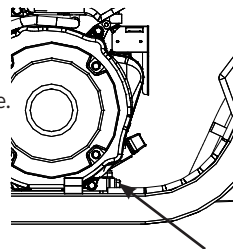

Insufficient oil in the engine can cause irrevocable serious damage to the engine.

11.3.3 Changing or refilling the hydraulic oil

- The total capacity of the hydraulic oil reservoir is 10gts.
- The hydraulic oil tank is positioned on the front of the machine (1).
- The fuel cap is located on the top of the reservoir. (2)
- The drainage plug is located at the bottom of the reservoir. (3)
- Make sure that the engine is horizontal.
- Hold a receptacle (capacity 12 gts) underneath the oil drain plug.
- Open the fill cap
- Open the sump plug and allow the contents to drain into the receptacle.
- Refit the oil drain plug.
- Refill the reservoir with fresh oil and replace the fuel cap.

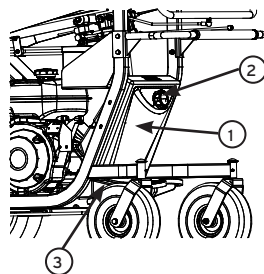

11.3.4 Changing the hydraulic oil and oil filter

- The filter should be changed after renewing the hydraulic oil.
- The filter must be turned loose, and replaced with a new filter.
- order number filter : BH 280 212 001

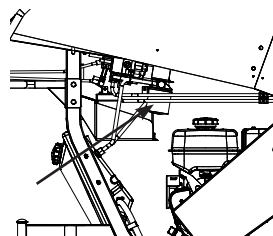

11.3.5 Cleaning the air filter

- Undo the hold-down clamps retaining the cover of the air filter (1) and remove the cover.

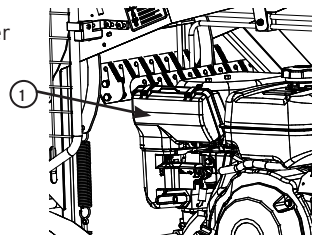

Caution :

If the engine has just been stopped, the exhaust will still be hot.

- Before removing the the filter, use compressed air to remove dirt and dust building inside the filter housing.
- Gently remove the pre-cleaner from the cartridge.
- Remove the nut and the sheet of the filter medium first and then remove the cartridge. (Prevent the carburettor from becoming dirty).
- Clean the pre-cleaner using liquid detergent and water. Dry the filter in a clean cloth, soak it in

oil then dry the filter again in an absorbent cloth in order to remove the excess oil.

- Clean the cartridge by tapping it gently against a flat surface.
- Refit the cartridge (with the UP mark showing upwards) and screw down.
- Refit the pre-cleaner to the cartridge.
- Refit the cover and secure the cover using the hold-down clamps.

11.3.6 Changing the air filter

These actions are almost identical to cleaning the air cleaner (see Chapter 11.3.5). The only difference here is that the cartridge is replaced.

New air cleaners of the correct type are available from your ELIET Dealer or from an authorized Honda or Subaru service centre.

11.3.7 Adding additional battery acid



Warning :

Battery acid is corrosive and therefore dangerous. Wear safety glasses and protective garment and work in a well-ventilated area.

- Switch off the engine.
- Check to be sure electrolyte level is between the minimum and maximum marks. Inspect the six compartments for correct level by looking through the transparent battery case.
- If the level is not correct, unscrew the caps from the battery.
- Use only distilled water to top up to the correct electrolyte level.
- Refit the caps to the battery.



Caution :

Do not inhale vapours from the battery acid.

During this maintenance, do not rub your eyes with your hands.

Should battery acid splatter into the eyes or onto the face, rinse the affected area immediately with clean cold water.

If there is any further discomfort, seek prompt medical attention.

Wash your hands immediately after performing this maintenance.

Note :

NEVER add additional acid, add only distilled water.

11.4 Machine maintenance

11.4.1 Checking and sharpening the blades

The machine offers the highest efficiency and has the highest operating speed when the blades are sharp. Enhance your own working comfort by taking some time to check the blades, and if necessary, sharpen them for every job.

SHARP BLADES = OPTIMUM PERFORMANCE

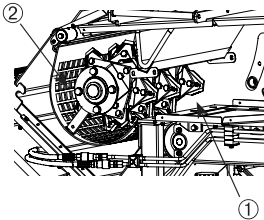

Pay particular attention to the following:

Shredding garden waste with the ELIET shredding system takes place in two steps. We first have the contact of the blades with the garden waste when chopping takes place where the cutting block can be found. The wood and green material is roughly cut into pieces until large irregular chippings are obtained during this **primary shredding (1)**. These large chippings end up in the shredding chamber where they are finely chopped to produce small chippings. This **secondary shredding (2)** will continue until the chippings are considered to be small enough to pass through the openings in the sieve screen or as soon as they're small enough to be ejected.

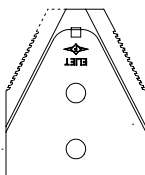
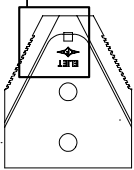
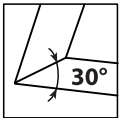
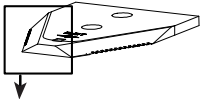
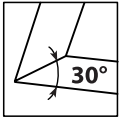
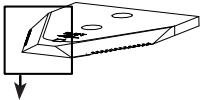

Each of these shredding actions set certain criteria that the blades must meet for an optimal shredding efficiency:

A) The top of the blade, in particular, is important with regard to the primary shredding. Since the blades act as splitting blades, the **cutting angle** is essential because this forms the key that will cleave through the wood. The cutting angle of the cutting edge of the blade is by preference 30°. The sharper the blade edge, the less resistance when splitting and the smaller the cutting impact on the structure. This will produce significantly fewer vibrations and noise. This will also benefit the load on the blade shaft and the bearings. You can ensure that the cutting angle is the best possible at all times by regularly grinding.

On the other hand, the form of the top of the blade is of essential importance for the performance and the speed of this primary shredding. The angle of the **top of the blade** will determine the angle at which the wood is pulled inside the shredding chamber. If this angle is rounded off due to wear, turn the blades around or replace them.

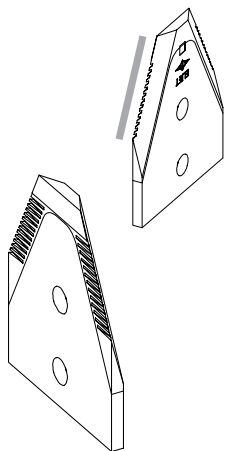

The issue is to have the chippings leave the shredding chamber as quickly as possible with regard to the secondary shredding. The chippings, therefore, must be quickly reduced until they are small enough to pass through the openings of the sieve screen. Every contact with the cutting area of a blade must make the individual chipping smaller. **The sharper the full active cutting edge** of the blade, the more efficient the shredding will be. Regular grinding of the cutting edge is essential.

The teeth on the cutting edge ensures that the cutting power of the blades increases and the cutting edge remains sharp for a longer period of time. It is very important to never grind away the teeth when performing maintenance on the blades.

The position of the blades on the blade shaft has been selected very specifically to obtain an alternative chopping configuration with regard to the primary shredding and the correct circulation of the chippings in the shredding chamber with regard to the secondary shredding. Always observe the original set-up of the blades when reversing or replacing them. (read § 11.5.3; p.59)

11.4.2 Sharpening the blades

Correct and timely sharpening of the shredding blades will extend their operating life (we recommend at least every 10 working hours).

Preparatory warnings

- Always wear safety glasses and hearing protection when grinding blades. Gloves are also mandatory for performing the maintenance work.
- NEVER turn the blade shaft by grabbing the blades. Use the large pulley as a wheel to turn the rotor.
- The blade has two cutting edges (reversible blade). This means that you must take into account when sharpening that there is another razor-sharp blade side.
- Remove all wood dust and chipping residue from the shredding chamber and around the blade shaft. This to ensure fire cannot occur once glowing sharpening fillings is deposited.
- Remove the key from the ignition for your own safety.
- Open the shredding chamber (read § 11.2.4; pag. 33).



For your information:

The blades can be sharpened without having to disassemble them. Use a small angle grinder with a grinding disc suitable for steel.

A blade has two sides.

- The front of the blade has the two chamfered cutting edges. **(F)**
- The rear clearly shows the teeth profile of the cutting area. **(B)**

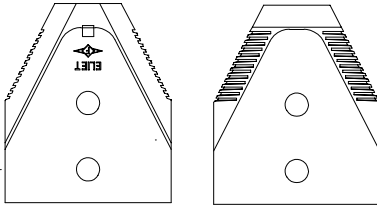

A sharp cutting edge and a correct cutting angle are essential for efficient shredding. These two properties of the blades are retained in position by correctly sharpening the blades.

- If blades become blunt, the sharp cutting edge will become worn and will be upset to form a wider rib. **(1)**
- By grinding a little metal from the cutting edge, you can again obtain a sharp cutting edge from this wide rib. **(2)**
- This grinding is performed by moving the grinding disc along the angled cutting edge θ_{GROUP}
- **Note:** By regularly grinding, you will only have to only grind away a small adjustment of the metal to again obtain a sharp cutting edge. This ensures that the times that you grind will be very short and will ensure that you always work with the best possible cutting edge. (ELIET recommends grinding every 10 working hours.)
- Avoid grinding at the same location for a longer period of time. Prevent local discoloration of blades; this denotes heating that causes the material structure to change locally and the hardness to decrease.
- It is extremely important that the existing cutting angle be respected when grinding. **(3: badly grinded blade)** θ_{GROUP}
- If the cutting angle is not maintained, blades will be stopped in the wood due to a blunt angle **(4)** of an interrupted cutting angle **(5)** and a lot of power will be lost. A cutting angle that is too sharp **(6,7)** will weaken the cutting edge and, therefore, the blade life of the blades will be significantly shortened (see pictures 4,5,6 and 7).

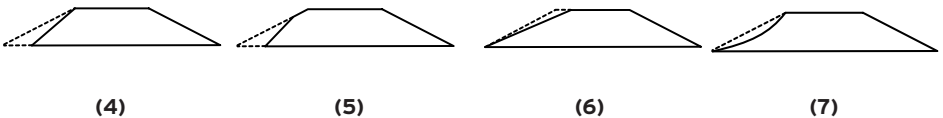
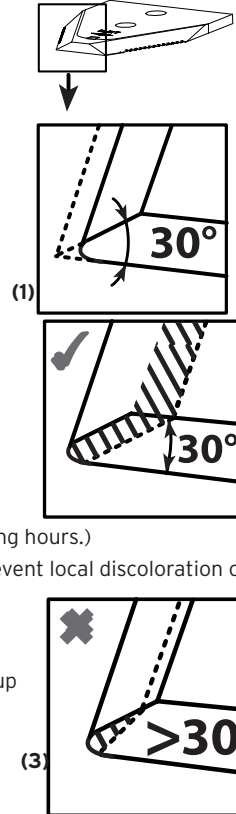

- Never grind the rear side of a blade. In the case of RESIST/10™ blades, the profile is on the rear side. If you grind away the teeth, the blade will lose a great deal of its cutting force.
- The top of the blade is subjected to the heaviest loads during shredding. Sharpen this as little as possible so that it is not weakened.
- Every time you grind you remove some material and the blade will become smaller on the active cutting side. You can continue to grind until you have reached halfway through the width of the top of the blade (see picture). Should you continue to grind, you would compromise the blade life of the cutting side that has not yet been used. Turn the blades when this happens (read § 11.4.3; p.41).
- If the top of the blade is rounded-off, (see picture) the shredding efficiency will be reduced. In this event, further grinding of the blade serves no purpose. This is the time to reverse or renew the blades. (read § 11.4.3; p.41)
- After grinding, carefully close the shredding chamber, refit the discharge belt conveyor and close the safety guards.

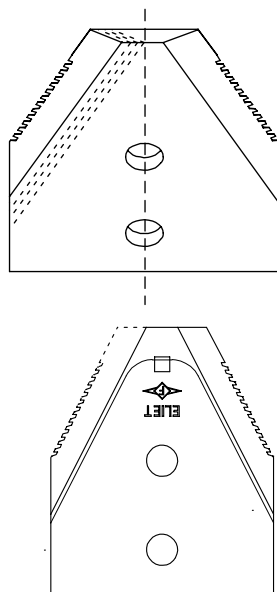

11.4.3 Reversing and renewing the shredding blades

If blades are sharpened at regular intervals, a blade life in excess of 100 hours for each blade edge can be guaranteed. When one blade edge has reached the end of its service life, simply reverse the blade, thereby enabling the machine to operate for another 100 hours. If both blade edges are worn, replace the blade as a set.

11.4.3.1 To reverse a shredding blade, proceed as follows:



Warning:

Wear protective gloves as the blades are razor sharp !

- Open the shredding chamber



Warning:

The blades are directly exposed as soon as the shredding chamber is open. Be sure that the machine has completely stopped and remove the key from the ignition.



For your information:

The blades are extremely sharp. Avoid contact with the blades en always wear protective clothings.

- Each blade is secured with two M10 bolts. Avoid injury to hands and always use two ring spanners with long handles to unscrew the bolts. (A/F 17)
- Immediately replace any damaged bolts.
- Do not pull away the blades using your hands but use a self-grip wrench.
- It is useful to put a wedge (screwdriver) in-between the blade disks to ensure it is easy to release them.

There are a few rules that must be respected for reversing or replacing the blades. The blade shaft has been divided into two groups for the logics of these rules:

Blade group 1: The two farthest blade disks belong to this group. (**G1**)

Blade group 2: This group contains 4 blade disks that are enclosed in-between the two farthest blade disks. (**G2**)

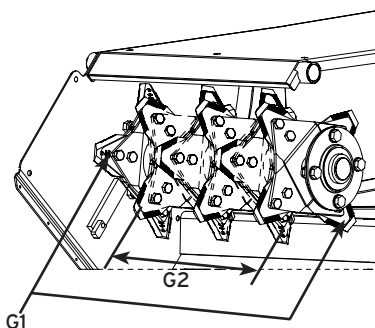

A Reversing the blades of group 1

Rule: Ensure that the blades from blade group 1 are always facing with their rear side (B) towards the side walls of the shredding chamber.

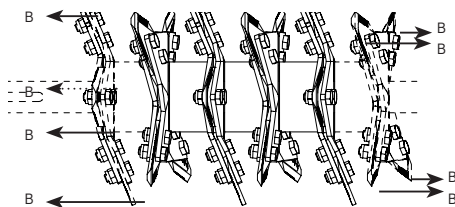

Perform the following steps to consistently apply this rule:

- Remove a blade from the left-hand side, rotate it through 180° and fit it in the same position, but to the right-hand disk. Rotate (180°) the blade previously removed from the right-hand blade disk, and fit it in the empty space in the left-hand blade disk. Repeat this procedure for each blade (8 x) of group 1.
- Always clean the blades and blade holders before reinstalling them.

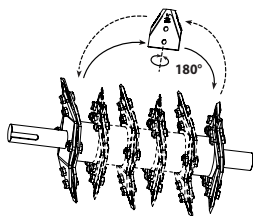

B Reversing the blades of group 2

Rule: Every blade disk has four blade positions. The blades are positioned at an angle for two positions (1) and the blades are approximately straight for two positions (2). The front side (F) of the blade must always be directed towards the axis line of the rotor for the slanted blades. One blade will point (F) the front side to the right and the other will point (F) the front side to the left for the straight blades.

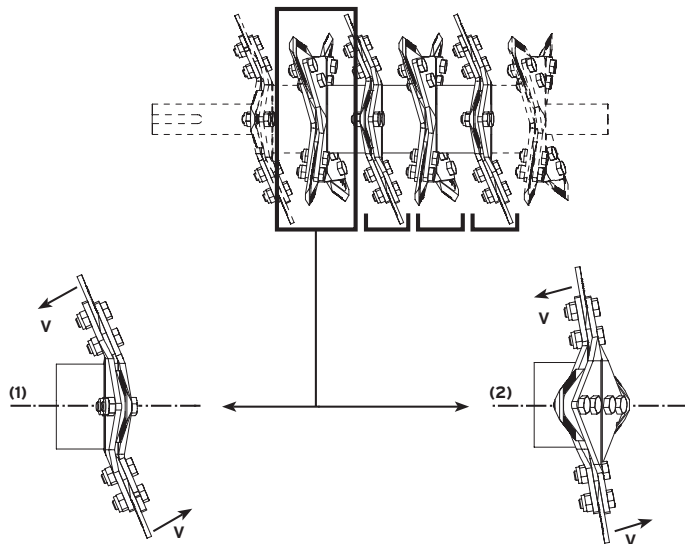

Perform the following steps to consistently apply this rule:

- Disassemble two blades that are diametrically opposite each other. Rotate them through 180° and change them over. Do the same with the two remaining blades. Repeat this operation for the three remaining blade disks of group 2.
- Always clean the blades and blade holders before reinstalling them.



Caution:

When fitting the blades, always position the nuts on the left-hand side of the blade plate. By applying this installation method, the nuts will be automatically tightened during shredding by the turning direction of the blade shaft. As a reminder: "Always position the nuts on the belt pulley side."

11.4.3.2 To replace a shredding blade, proceed as follows:

- New RESIST/10™ sets are available from your ELIET Dealer under the following Art. n° BU 401 300 202
- Disassemble all bolts (M10) that secure the blades. Always use two ring spanners with long handles to unscrew these bolt attachments. (A/F 17)
- Do not pull away the blades using your hands but use a self-grip wrench.
- It is useful to put a wedge (screwdriver) in-between the blade disks to ensure it is easy to release them.
- First remove any dirt between the blade plates before you insert a new blade. To do so, use a stripping blade.
- Use the same procedure as for reversing the blades:

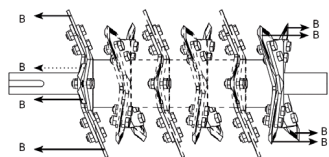

(B)

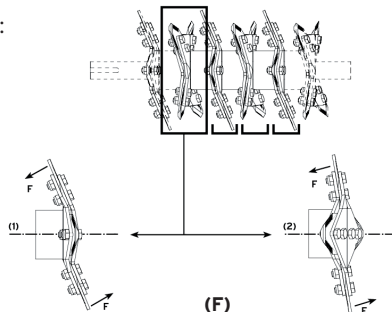

(F)

Group 1: Check that the rear of each blade faces towards the wall **(B)** of the shredding chamber.

Group 2: Each blade that is mounted on a fluted part of a blade disk must face the axis line of the blade shaft with its front side **(F)**.

- On replacing shredding blades, always fit new bolts and nuts.
- When refitting the shredding blades check that all bolts are tight (torque loading: 25 Nm)
- When refitting the bolts in the discs, always make sure the nut is located on the left side of the disc. As a reminder: "All nuts in the blade shaft must always be positioned along the side of the pulley"
- After reversing or replacing the blades, always check the torque of the blade bolts after the first 5 working hours and adjust, if required.



Caution:

- Incorrectly or poorly installed blades may lead to the machine breaking down or being damaged. This will also put operators and bystanders in danger.
- Not retightening the blades after the first 5 working hours after reversing or changing the blades may lead to the machine breaking down or being damaged.
- The damage and consequential damage that may arise from poor maintenance of the blades will invalidate the warranty.

11.4.4 Checking and tightening the drive belt for correct tension

- Remove the belt guard (Chapter 11.2.1).
- You can obtain the correct belt tension if you apply a point charge of 17lbs halfway through the distance between the centres of the pulleys and you can measure a deflection of 1/2" on the belt.

11.4.5 Tightening the belt for correct tension

To tighten the belt, proceed as follows:

1. Disconnect the belt drive by putting the right pedal in upright position.
2. Loosen the nut (M10) on the control rod with a 17mm spanner.
3. Pull out the beta pin.
4. Rotate the control rod 2 times to the right to tension the belt.
5. Place the control rod back in the engine plate and replace the beta pin.
6. Tighten the nut on the control rod (17mm spanner).
7. Check the belt tension.

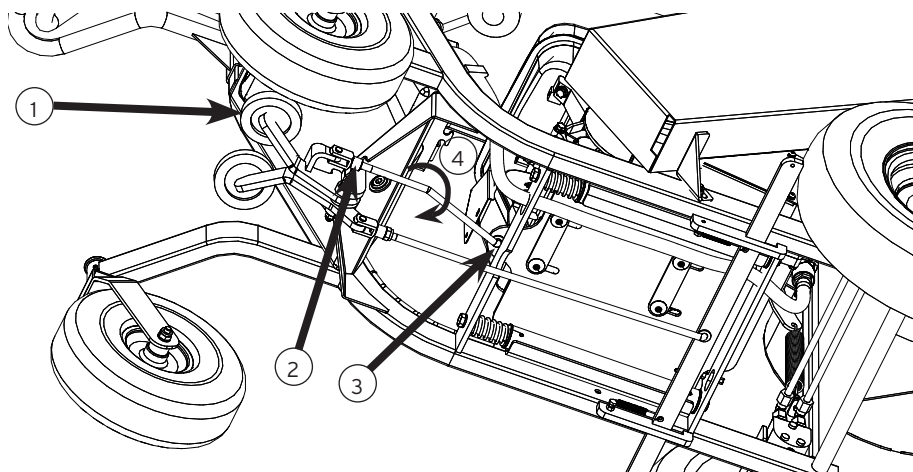

CAUTION: in case of overtensioning, the clutch will not disengage.

If the belt is still too loose, please repeat these instructions.

11.4.5 General lubrication

In view of the fact that the shredders often operate in extreme conditions, ELIET considers it important to use high-quality materials. ELIET therefore recommends the use of special lubricants (from the assembly stage onwards).

The following parts require regular lubrication:

- Pivot points and friction surfaces.
- Grease zerks.
- Bearing.



Caution :

Before performing lubrication, make sure to switch off the engine and to remove the key from the ignition switch. Gloves must also be worn during this maintenance.

A. Lubrication of pivot points and friction surfaces

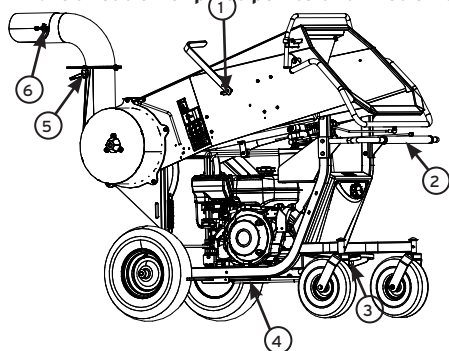

This group includes the following locations on the machine:

- 1) Pivot point lever infeed roller
- 2) Throttle control lever pivot point
- 3) Parking brake foot pedal
- 4) Wheel drive brake guide
- 5) Pivot point handle blowchute
- 6) Bolt deflector flap

7) Pivot points of the safety guard

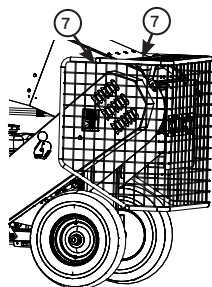

Use the following procedure :

- Whenever possible, disassemble the hinge or the joint.
- Spray some penetrating oil containing molybdenum disulphide onto the frictions surfaces and allow the oil to penetrate.
- Wipe away all traces of old lubricant and dirt.
- In the event of some parts not being accessible, use compressed air to remove all traces of old lubricant and dirt (e.g. in the joints of pivot points).
- When the pivot points are clean, apply new lubricant.
- ELIET recommends Novatio Clearlube as a lubricant for pivot points and ball joints. ELIET would recommend Novatio PFT grease for friction surfaces.
- Wipe away any excess lubricant.

B. Greasing via the grease zerks fitted

This group includes the following locations on the machine:

Grease zerk on the pivot point of feed roller (1)

Grease zerks on pivot point of castors (2)

Grease zerks on the bearings of the castors (3)

Grease zerks on the shifting plate beneath the engine (4)

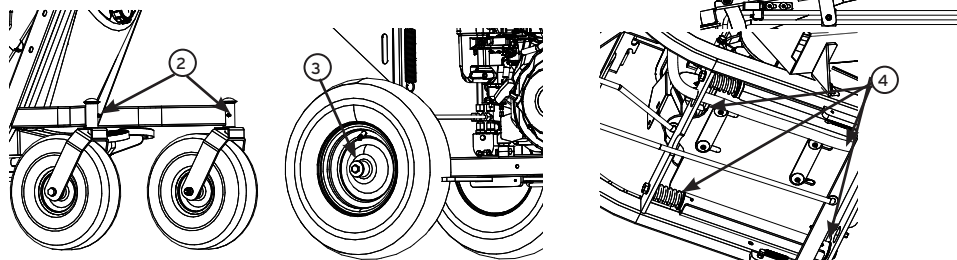

Use the following procedure :

- Clean the grease zerk.
- Using a suitable grease pump, apply new grease.
- ELIET recommends Sunoco Multi Purpose Grease.
- Pumping the grease gun one or two times is sufficient to distribute the grease.
- Wipe away any grease that comes out of the joints.

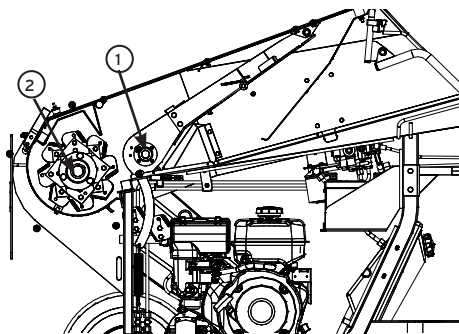

C. Lubricating the bearings

This group includes the following locations on the machine:

- 1) Bearing of the feed roller
- 2) Bearing of the blade drum on both sides of the blade drum

Use the following procedure :

- Spray some penetrating oil containing molybdenum disulphide into the bearing and the area around and allow the oil to penetrate.
- Wipe away any external dirt.
- Spray more penetrating oil into the bearing joints.
- Allow the bearing to rotate (possibly by starting the drive that moves the bearing). (CAUTION: make sure that all dangerous zones are adequately shielded).
- Once again, wiped away any dirt that is forced out by the penetrating oil.
- Use compressed air to remove all traces of penetrating oil from the bearing and from the bearing joints.
- Apply new lubricating oil. ELIET recommends Novatio ClearLube as a lubricant.
- Wipe away any excess lubricant.

11.5 Maintenance schedule

11.5.1 Normal maintenance schedule

Daily (after each use) :	Daily maintenance	§ 11.5.3
Every 50 hours :	Maintenance after 50 hours	§ 11.5.4
Every 100 hours (six-monthly) :	Maintenance after 100 hours	§ 11.5.5
Every 200 hours (or annually) :	Maintenance after 200 hours	§ 11.5.6

11.5.2 Special maintenance

A. Special maintenance of the blades

After inserting the blades into the rotor, the blades will bed-in after a brief period. This can cause the tension on the bolts to decrease, with the risk that the blades may become dislodged between the blade plates. This can cause irrevocable fatigue failure of the blade shaft. This must be prevented by scheduling extra maintenance after the brief bedding-in period.

When: Within the first five operating hours after starting up the new machine
 Within the first 5 hours after rotating the blades
 Within the first 5 hours after changing the blades

What: Check all blade bolts for correct torque loading and retighten if considered necessary.
 (torque loading : 40 Nm - 350 in lbs)



Warning :

Failure to perform this special maintenance will compromise the safety of the operators and bystanders and can cause serious damage to the machine.

B. Special maintenance of the drive belt

The belt that transfers the power from the engine to the blade shaft is long. During the bedding-in period, the belt will stretch naturally to a certain extent. This stretching will reduce the belt tension. Using the machine when the belt tension is too low will cause the belt to slip, twist or wear down. These three possibilities have a detrimental effect on a new belt.

When: Within the first 10 operating hours after starting up the new machine
 Within the first 10 hours after changing a belt

What: Check the belt tension

11.5.3 Daily maintenance



Caution :

Before performing any maintenance, stop the engine.
 Wear suitable clothing.

- Check for signs of leakage.

- Open the shredding chamber (see Chapter 11.2.4).
- Clean the machine (see Chapter 9.8)
- Inspect the blades, and if necessary, sharpen them (see Chapter 11.4.1)
- Check the machine for signs of abnormal wear or fractures.
- Check the bolts for correct tightness. (Blades, wheels, bearings, engine,...).
- Check the oil level in the engine crankcase (see Chapter 11.3.1).

11.5.4 Maintenance after 50 hours



Caution :

Before performing any maintenance, stop the engine and remove the key from the ignition switch.

Wear suitable clothing.

- Daily maintenance.
- Clean the air cleaner.
- Check the belt tension.
- Check the level of hydraulic oil.
- General lubrication.

11.5.5 Maintenance after 100 hours (or six-monthly)



Caution :

Before performing any maintenance, stop the engine.

Wear suitable clothing.

- Maintenance after 50 hours.
- Reverse RESIST™ blades
- Replace the oil filter
- Check the level of battery acid

11.5.6 Maintenance after 200 hours (or annually)



Caution :

Before performing any maintenance, stop the engine.

Wear suitable clothing.

- Maintenance after 100 hours.
- Change blades
- Changing the hydraulic oil and oil filter.
- Air cleaner change.
- Changing spark plugs.

After performing maintenance or a repair, make sure that you correctly refit ALL guards.

12. Winterizing the machine



- Clean the machine
- Store the machine in a dry place that is protected from rain, and if necessary, cover it with a tarpaulin.
- Always allow the machine to cool down before storage.
- If the machine is to be stored outside, it must be well protected with a tarpaulin. Ensure that water does not directly fall onto the machine. At ELIET, we strongly recommend that the machine is stored at a location that is well protected from the weather, etc.
- When winterizing the machine for long periods, it is recommended to perform the following steps.
- Perform a 50-hour overhaul.
- Check all nuts and bolts for correct tightness, and where necessary, retighten them.
- Places where the paint coating is damaged are repainted or covered with grease in order to prevent rust. Original ELIET paints in the same colour are available from your ELIET Dealer (article no.: BX 043.200.400).

13. Equipment specifications

	PROF V	PROF V B-E
	(without blower)	(with blower)
Engine	13 HP Honda GX390	14 HP Subaru EX40 ES
Chipping capacity (mm)	80 mm / 3 1/4 "	80 mm / 3 1/4 "
Chipping capacity per hour	750 kg (3m ³) / 1650 lbs	750 kg (3m ³) / 1650 lbs
Chipping surface	400x120mm / 16x4 1/2"	400 x 120 mm / 16x4 1/2"
Weight	284 kg / 627lbs	324 kg / 715lbs
Dimensions (mm)	1680x750x1390	1680x750x1470
Dimensions infeed (BxH)	560x500mm / 22"x19"	560x500mm / 22"x19"
Infeed hight	1030 mm / 40"	1030 mm / 40"
Blowing pipe	\	360° SWIVELLING DISCHARGE HOSE
		deflector-flap adjustable in height
Steel turbine	\	Ø 330 mm - width 130 mm / Ø 13" - width 5"
Different models	STD	STD
	Hydro	Hydro
	Hydro ZR	Hydro ZR
Options	Electric Start	ABM system
	Multi purpose grating for wet greenwaste	

14. Prof 5 PTO

Safety precautions

- **Protective plate:** behind the Prof 5 4S PTO, there is a protective plate that ensures that the operator cannot reach the blades with his hands if the machine is connected to the tractor.

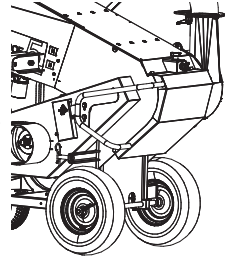

Connecting propeller shaft

- Make sure that the turbine is completely free of clippings and that the blade axle can turn without obstruction.
- Ensure that the protective plate of the Prof 5 is closed and clicked shut. If the protective plate is not secured, the propeller shaft cannot be secured to the Prof 5.

- Connect the tractor to the Prof 5's 3-point connector. The machine can only be used if all three points are secure.
- Use the upper connection of the 3-point connector to adjust so that the Prof 5 hangs flat.
- The white ring on the propeller shaft's connection slides back. Until the propeller shaft has been clicked into place, it has not been connected properly.
- If the Prof 5 is connected to a tractor with a capacity greater than 13hp, use a propeller shaft with a slip coupling. ELIET is not responsible for damage to the machine as a result of using a tractor with an excessive output capacity.

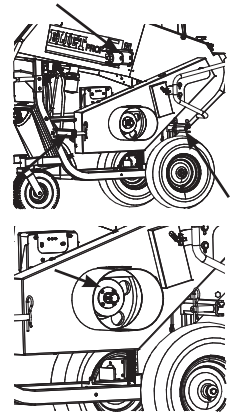

Using the machine

- The Prof 5 PTO runs at a PTO speed of 540 rpm. Eliet is not responsible for damage to the machine if excessive PTO speed is used.
- Set your tractor's accelerator so that the revolutions are 540 RPM.
- Set the machine flat on the ground before starting. The Prof 5 may not be used in transport mode.
- Direct the blow chute to the desired position before beginning to cut. Do this by dismantling the blow chute (see Annex B2) and then installing it in the desired position.
- If you hear a strange noise, when there is a blockage or during other unforeseen circumstances, the propeller shaft must be switched off immediately.

Maintenance Prof 5 PTO

- During maintenance work, the propeller shaft must always be disconnected; this is also a requirement in order to remove the protective plate and access the clippings chamber.

Belt tension adjustment

- In order to adjust the belt tension, the protective plate must be adjusted. Unhitch the lever (1) and undo the star-screws (2) on the protective plate in order to release the protective plate.

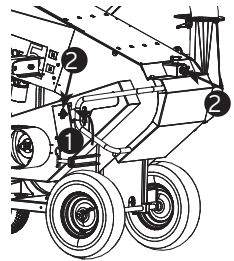

- The protective guard must also be removed. To do so, the 4 M6 bolts (without nut) must be unscrewed. The cap is also fixed to the chassis with an M6 bolt which has a cap nut and an M8 bolt at the front of the cap. Two ring spanners (10 mm and 13 mm) are required for this.

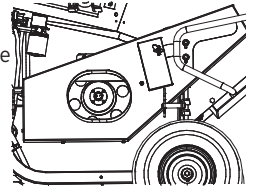

- In order to check the exact belt tension, a weight of 7.5 kg must be hung on the V-belt. If the belt sags 1 cm, the belt tension is correct.
- Tension the belt by sliding the flat plate on the chassis forwards. The plate bolts must be unscrewed in order to do so (2 x ring spanners 13).

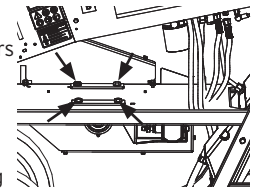

- Before unscrewing the machine, a felt-pen must be used to make two points on the chassis plate. This will save time afterwards when lining up the pulleys.
- If the correct tension and alignment is achieved, the plate can be locked by re-tightening the bolts (M8) (ring spanner 13).
- Only once everything has been checked carefully can the protective cap be replaced in its original position.
- Replace the protective plate and tighten the button on the back sufficiently to avoid overloading the coupling mechanism.

15. EC Declaration of Conformity



Machine: **WOOD CHIPPER**
Type: **ELIET PROF V**
Model number: **MA 026 010 209**
MA 026 011 439
MA 026 020 209
MA 026 021 439
MA 026 030 209
MA 026 031 439

The previously mentioned machine has been designed and manufactured to comply with the following European CE regulations :

EN 13525: Forestry machinery : wood chippers - safety

ELIET mfg. cy. hereby declares that after performing a hazard analysis, it is fully aware of the potential hazards and risks associated with the machine. In this knowledge, the necessary steps have been taken in line with Machine Directive 2006/42/EC in order to ensure absolute operator safety for the operator, when the machine is used correctly.

The value of the measured sound power level and the guaranteed sound power level were obtained according to the procedures set forward in the directive 2000/14/EG annex III/B clause 50 and directive EN 13525..

Measured sound power level LwA : 115 dB(A)

Guaranteed A-weighted sound power level : 116 dB(A)

Date: 01/06/2012

Signature:

A handwritten signature in black ink, appearing to read 'Frederic LIETAER', written over a light blue rectangular background.

Frederic LIETAER

Managing Director ELIET EUROPE NV

Date of birth: 02/01/1975

ELIET EUROPE NV

Diesveldstraat 2

BE - 8553 Otegem Belgium

Ph. +32 56 77 70 88 - Fax +32 56 77 52 13

info@eliet.eu - www.eliet.eu

16. Warranty-conditions

Dear Customer,

We thank you for purchasing an ELIET product. Congratulations on your purchase of this machine which is sure to meet your expectations and needs over the coming years. At Eliet, we do everything to ensure that our products function correctly. That is why your product qualifies for a two year guarantee.

What is warranty ?

At Eliet, we have strict quality rules on designing and manufacturing products. The priorities given by these rules are to guarantee a long service life and permanent safety. That is why at Eliet, we are willing to repair at no charge hidden defects or faults during the whole run-in period (aka the warranty period), provided the prescribed procedure is followed.

Warranty conditions

ELIET's warranty obligations for new machines is governed by the following conditions.

I. Warranty period

The warranty period starts the day the dealer delivers the machine to the customer (maximum one week after the purchase) and expires :

- after two years of private use.
- after twelve months or 100 running hours of rental use.
- after twelve months or 100 running hours in semi-professional or in professional use.

To be eligible to obtain warranty the customer is invited to register the newly purchased machine with ELIET. You should complete the registration card online on Eliet's website : www.eliet.eu.

If you don't have access to the Internet, please complete the attached registration card in its entirety and return it to ELIET.

II. What is covered by the warranty ?

- Wear items are not covered by the warranty conditions : (such as blades, bearings, belts, chains, gearwheels, tyres, bulbs, fuses, etc).
- If failures are found to be caused by improper use, neglect or consequential damages by an external source (fall, chippings, foreign objects, accident).
- If failures are found to be caused by improper maintenance of the machine, that is not in accordance with the prescribed periodic maintenance.
- When a defect is caused by improper repair made by anyone other than an authorized ELIET dealer or after using not genuine Eliet service parts.
- When the defect is caused by making improper changes to the original design of the machine.
- When the fault develops when the machine has been used not in accordance with the instructions contained within this manual.
- When the prescribed warranty procedure has not been adhered to or when the warranty pe-

riod has expired.

- For all problems relating to the motor, please contact an authorized service centre of the engine manufacturer.

III. Procedure

- **Step 1 :** On the date of purchase, the customer should register his/her purchase online by completing the registration card at www.elieta.eu. In addition, the enclosed registration card should be completed in its entirety on the day of purchase. The first part of the form should be returned to ELIET within one month. The customer should keep all remaining parts of the card along with the purchase invoice for the duration of the warranty period.
- **Step 2 :** In the event of a defect becoming apparent, the customer shall have this verified by the authorized ELIET dealer. If the dealer feels that there is a factory defect, the dealer may invoke the warranty, under the terms specified.
- **Step 3 :** Every warranty application must be accompanied by a fully completed official application form. Copies of this warranty application are available to dealers at ELIET or even at an importer/agent.
- **Step 4 :** The dealer then orders the parts needed to perform the repairs. Next, the dealer faxes the order form together with the completed warranty form and a copy of the registration card.
- **Step 5 :** The warranty form should be stapled to the purchase invoice and mailed to ELIET or an importer/agent of ELIET.
- **Step 6 :** ELIET will send the parts ordered to the dealer under the regular delivery and payment conditions.
- **Step 7 :** The defective part will be examined by the technical department first prior to approving or rejecting the warranty. ELIET reserve the right to solely decide whether or not the customer has complied with the conditions for the validity of this guarantee, i.e. 1 year or 2 years. Faulty components shall become the property of ELIET.
- **Step 8 :** When a warranty claim is found to be valid, ELIET will credit the warranty parts. Customers shall never be entitled to apply for a refund of labour costs.

IV. In case of damage caused by transport

- All goods are supplied ex factory. Transport risks are borne by the customer. It follows, that ELIET highly recommend to check the goods for damage on arrival.
- Any damage found should be stated on the delivery form before signing. Make sure the driver of the haulage company puts his signature next to the damage on your copy.
- In the absence of a written and signed declaration on the delivery form, the insurance of the haulage company will not accept any liability.
- Damages can be claimed from the hauler using a copy of the delivery form and a covering letter stating your complaint.
- The damaged machine should be kept in its original condition until the hauler's insurer has performed any examination.

REGISTRATIONCARD**ELIET CUSTOMER SERVICE**

To be able to claim the full rights to which you are entitled, it is important to register within a month after the date of purchase. Therefore fill out this registration form and return the first registration card to the ELIET Customer Service. Your purchase should be registered on the ELIET website: www.eliet.be

REGISTRATIEKAART**ELIET KLANTDIENST**

Om als klant, aanspraak te kunnen maken op waarborg dient men zich binnen de maand na aankoop bij ELIET te registreren. Hiervoor vult u onderstaand document volledig in en stuurt het eerste deel van deze registratiekaart naar de ELIET klantendienst terug. Registreer uw aankoop op de ELIET website www.eliet.be

CARTE**SERVICE**

Pour profiter de tous les avantages à vous sont à enregistrer dans le mois suivant l'achat. Complétez donc entièrement et renvoyez la première au Service Client. Registrez votre achat sur le site Internet ELIET: www.eliet.be

ELIET

Registration card
Registratiekaart
Carte d'enregistrement
Registratiekaartje

ELIET Customer Service
Zweverwegstraat 136
B-3000 Oostm
Belgium

Customer Identity / Klantgegevens / Données du Client / Kundendaten

Name / Naam / Nom / Name		First Name / Voornaam / Prénom / Vorname	
Street / Straat / Rue / Strasse		Nr / Nr / N° / Nr	
City code / Postnr / Code Postal / Postleitzahl		City / Plaats / Ville / Stadt	
Telephone / Telefoon / Téléphone / Telefon-Nr.		Fax / Fsk / Télécopieur / Fax	
E-mail		Box / Bus / Boite / App.	
Country / Land / Pays / Land			

Machine identity / Machinegegevens / Données de machine / Daten Maschine

Model / Model / Modèle / Modell		Year of manufacture / Bouwjaar / L'année de construction / Baujahr	
Article Code / Artikel code / Code d'article / Artikel-Nr.		Serialnumber / Seriennummer / Numéro de série / Serien-Nr	
Date / Datum / Date / Datum			
Signature Handtekening Signature Unterschrift	Stamp of dealer Stempel van handelaar Cachet de revendeur Stempel Fachhändler		

I declare that all information that was filled in is correct and truthful. I also declare to have read and understood the operation manual and the warranty conditions. Ik verklaar dat al deze gegevens waarheidsgetrouw werden ingevuld. Hierdoor geef ik te kennen de gebruiksaanwijzing en de garantievoorwaarden te hebben gelezen en begrepen. Je déclare que tous les données complétées sont correctes et véridiques. Je déclare également d'avoir lu et compris les notices du mode d'emploi et les conditions de garantie. Ich erkläre hiermit, dass alle angegebenen Daten korrekt und wahrheitsgemäß gemacht wurden. Ich erkläre ebenfalls, dass ich die Garantiebedingungen gelesen und verstanden habe.

Put a crossmark to which application this machine was used

Zet een kruis bij de toepassing waarbij deze machine wordt ingezet
Indiquez avec une croix l'emploi pour lequel la machine a été utilisée.
Kreuzen Sie an, für welche Art von Gebrauch die Maschine bestimmt ist.

- Home use / Particulier gebruik / Usage particulier / Private Nutzung
 Professional Landscaping / Hovertiersbedrijf / Usage Professionnel / Gewerbliche Nutzung
 Forestry / Bosbouw / Forêt / Forstbetrieb
 Public Groundscafe/ Openbare groenvoorziening / Espaces Verts Public / Öffentliche Grünflächenversorgung
 Rental / Verhuur / Location / Vermietung

Dit document dient binnen de maand na aankoop teruggestuurd te worden naar de ELIET Klantendienst.

This document has to be returned to ELIET Customer Service within a month after purchase.

Renvoyez ce document au Service après-vente ELIET dans le mois suivant à la date d'achat.

Dieses Dokument muss innerhalb eines Monats nach Kaufdatum an den ELIET Kundendienst zurückgeschickt werden.

17. Hazard analysis

Below you will find a list of dangers and risks that are linked to storing away, transporting or using the chipper. Take note of these dangers and avoid these risks by following the instructions contained in this manual. Be aware that it is not just the user who runs a risk but also third parties can be exposed to these risks. Ensure that bystanders are always kept at a safe distance.

- Injury to hands due to reaching into the infeed opening past the anti-projection flaps.
- Injury due to the projection of chippings through the feed-in opening because the anti-projection flaps have been pressed open.
- Danger of suffering heavy injuries or death because a machine part (blades, bolts, etc.) have become loose because there has been a lack of checking and maintenance.
- Danger of suffering injuries due to projection along the feed and discharge sides after a foreign object has been introduced (stone, metal, textile, PVC, etc.).
- Injuries caused by chippings flying out from the discharge opening when the machine is in operation.
- Injury due to the projection of chippings by walking into the danger zone around the blow chute.
- Cutting injuries to hands due to injury from the blade shaft coasting to a stop on opening the chipping chamber.
- Cutting injuries to hands when disassembling the blade shaft.
- Cutting injuries due to the blade shaft falling after being disassembled.
- Strangulation or constriction by loose clothing getting caught in moving parts.
- Injuries caused by the machine tipping due to unsafe transport.
- Danger of suffering burns due to chippings and wood residue that is blocking the cooling air ducts.
- Irritation of the airways or lung problems due to inhaling the dust produced.
- Hearing disorder due to insufficient protection of the ears during the work.
- Bruising or injury when feeding materials, due to the power of the blades on the wood.
- Bruising or injury due to the kick-back of wood when being introduced in the feeding hopper.
- Mental disturbance or rheumatic disorder due to shredding for a long time at a time without taking breaks.
- Joint pain due to vibration transfer when continuously inserting thick branches.
- Injuries following contact with the blades for blockage clearance, maintenance or cleaning the machine.
- Injury due to a fall while driving over a substrate that cannot carry the weight of a person and machine.
- ...

This is not a comprehensive list and is provided for information purposes only to safeguard the safety of the user.

