



For Earth, For Life
Kubota

M

KUBOTA M5001 SERIES

5091 – 5111





**Fresh
thinking is
the answer
to today's
challenges.**

The challenges facing the agricultural sector are becoming increasingly bigger. And when times are tough, only one thing helps: a new way of thinking. Envisaging alternative options and making smart decisions. For your next tractor purchase, this means opting for efficiency instead of image. For a tractor that can do tough work with top performance whilst under constant strain. And all that at a reasonable price. A Kubota tractor is exactly the right alternative at times like these.





**Tough times
need
unexpected
tough
performance.**

When it becomes increasingly more difficult to be successful, the time has come to take an uncompromising approach. And this means demanding unquestionable quality and reliability. Kubota meets these requirements with engines, which meet expectations when things get tough. You will be surprised by their performance, power, and fuel efficiency.





**A new
understanding
of farming
enabled by
a global
player.**



To be a partner who can facilitate new ways of thinking requires a certain degree of power and seriousness. Did you know that Kubota is a global, rapidly growing company for the professional agricultural sector? Just take a look at the decisions and steps we have taken in the last 4 years. Surprised?

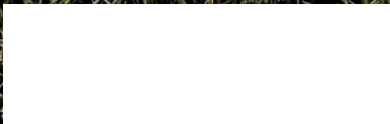



A future-oriented portfolio doesn't end with tractors.



The requirements in agriculture are not only high, but also comprehensive and diverse. Fortunately, Kubota has exactly the right solution for every task—and from a single source. With a huge implements programme on the market and the Kubota ISOBUS production, we are your partner who thinks ahead and makes things possible. All machines and processes are perfectly compatible with each other and guarantee the highest level of quality and efficiency, not to mention future viability.

#Highlights

M5001: The smart go-getter

The Kubota M5001 is the smart go-getter in its class—this very maneuverable professional tractor proves that true greatness comes from within. With its powerful engine, an excellent transmission, high ground clearance, and exceptionally simple operating controls, it quickly becomes indispensable for daily work. Put its great class to work and take care of tough jobs quickly.

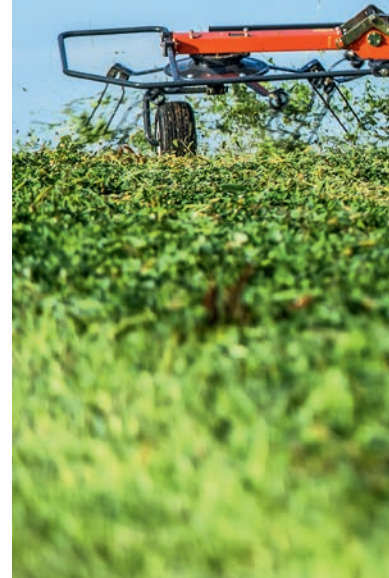

Extremely powerful

The 4-cylinder engines with 95 and 113 hp (DIN 97/68 EC) have impressively reliable power and high efficiency.

Tremendously environmentally friendly

Of course, the V3800 engine meets the strict requirements of the Stage IV Final emission standard.

Amazingly comfortable

With its 36 forward and 36 reverse gears, the M5001 shifts extremely easily and comfortably.



Extremely maneuverable

The front axle bevel-gear with greater all around maneuverability and higher ground clearance make the M5001 extremely agile and maneuverable.

Surprisingly comfortable

The comfortable and generous cab provides an optimal panoramic view. Thanks to the clear arrangement of all control elements, not a movement is wasted.

Impressively precise

The M5001 is much more than a tractor. With ISOBUS retrofit terminals and Kubota implements, it is the answer to any challenge. And with the potential of precision farming solutions, it saves time and money.

Market-leading technology under the bonnet

A tractor like the Kubota M5001 is designed for different tasks that require excellent manoeuvrability as well as the demanding operation of PTO-driven implements. Thanks to its ingenious engine technology, the M5001 can handle such tasks with ease while being environmentally friendly at the same time.

Powerful, reliable, clean, and quiet—the V3800 four-cylinder engines in the two M5001 series models M5091 and M5111 impress with their proven, reliable performance and higher efficiency, also benefitting the environment. This is possible due to the globally leading diesel engine technology from Kubota.

This combination makes all the difference

The common rail system (CRS) optimises combustion, resulting in a durable and quiet engine. Kubota is the first tractor manufacturer to use a common rail injection system together with an SCR catalytic converter, AdBlue®, water-cooled exhaust gas recirculation (EGR), diesel particulate filter (DPF), and diesel oxidation catalytic converter (DOC). The combination of this market-leading technology produces excellent performance values with optimised fuel efficiency. It goes without saying that the V3800 engine with 16 valves meets the strict requirements of the latest Euro Stage IV emission standards.

An engine optimised for performance and torque

With the new engines for the M5001, Kubota has improved performance and torque values while simultaneously lowering the engine speed level. It now runs more quietly, offers greater wear resistance and lower fuel consumption.

Useful speed monitoring

The engines also feature a new electronic speed controller to govern the speed of the engine. Once the system has been activated, the speed remains constant, even when the demand for power varies. As a result, PTO-driven implements can be run more efficiently.



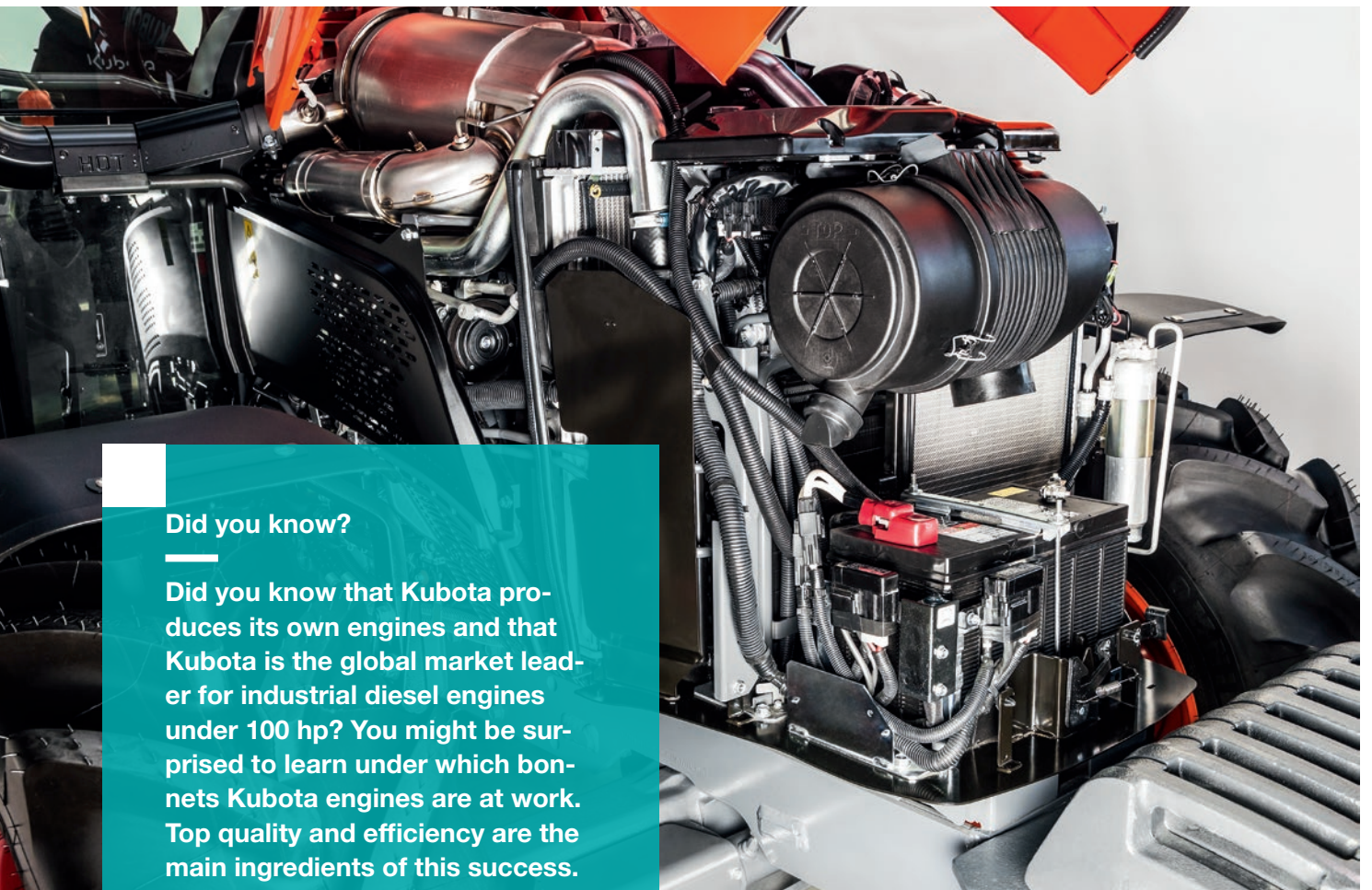

Did you know?

Did you know that Kubota produces its own engines and that Kubota is the global market leader for industrial diesel engines under 100 hp? You might be surprised to learn under which bonnets Kubota engines are at work. Top quality and efficiency are the main ingredients of this success.

Operating your tractor is bound to include some of the same recurring tasks, such as certain PTO driven jobs. That is where the integrated speed memory comes into play. You can recall each setting with just the touch of a button. Without any further adjustments, you're ready to go.

Maintenance in a fast, convenient, and efficient way

Knowing that you have more important things to do than spending a lot of time on maintenance, we made sure the M5001 sets the benchmark here too. The tractor's one-piece bonnet opens wide, allowing easy, unhindered access to all maintenance points. Filling up is just as easy as maintenance. The 105-litre diesel tank and the 12.3-litre AdBlue® tank can be safely and conveniently filled up from the ground.



Easily change into a higher gear

The user-friendly transmission of the M5001 provides a very smooth and easy gear change. With 36 forward and 36 reverse gears, it covers all requirements—from field and pasture work to vegetable plots.

Direct, smooth gear changes

The transmission of the M5001 does not lag behind the engine in terms of performance. With six synchronised gears with Dual Speed technology in three ranges, you have 36 forward and 36 reverse gears to choose from. The transmission lets you change gears directly and extremely smoothly.

The right gear for any task

With just a single shift lever, the fully synchronised transmission provides the power and efficiency you need for everyday work. Whether fast and fuel-efficient transport trips, quick pasture jobs, or accurate field work—the transmission is optimally matched to any task. Even vegetable farmers are sure to find the right gear in the standard creeper speed group.

Sensitive and precise hydraulic shuttle

The drive clutch can be operated very precisely for coupling machinery. For such slow manoeuvres, you can use the clutch pedal to control a hydraulic valve that engages the clutch smoothly and precisely. This will give you easier operation that is less strenuous.

Drive fast and save fuel at the same time

The tractor's transmission cruising gear keeps the engine speed low thanks to the overdrive technology for high-speed trips. This 40-ECO transmission gets you to your destination quickly and saves fuel at the same time.

Easy change of direction

With the electro-hydraulic shuttle lever of the Kubota M5001, you can change direction faster and easier than ever, without having to use the clutch. Just move the hydro shuttle briefly forwards and backwards.





Did you know?

Did you know that Kubota has held a leading position in the fields of construction machinery and compact tractors for many years in Europe? You will find the same experience and keys to success applied to the professional agricultural market.

The shuttle lever is within easy reach on the left side of the steering wheel. The tractor does not need to come to a stop to perform this shuttle operation. When working with the front loader, which requires frequent back-and-forth movements, it's a true blessing to be able to change direction without having to press the clutch every time. Increased productivity is guaranteed.

Safety on board

Kubota positioned the park lock separately from the shift lever in the M5001. You can quickly set the brake and release it again at the push of a button.





A strong partner: lift heavy loads with ease

The hydraulic power and lift capacity of the M5001 speak for themselves. It can lift a combination of front and rear disc mowers with ease. So you can really get things moving, literally.



Raise rear implements effortlessly

The strong 3-point category II power lift enables the M5001 to raise heavy attachments with ease. Various machines can be quickly and easily attached and removed. In combination with the outstandingly powerful 3-point lift, you can handle even the most challenging tasks with great efficiency.

Lift heavy loads with ease and power where needed. The hydraulics of the M5001 are extremely powerful and respond quickly. External hydraulic cylinders for easy maintenance increase the lift capacity. The hydraulic pump has the capacity to guarantee both rapid and effective front loader operation, thereby improving productivity and performance. The standard equipment includes two control valves and an additional hydraulic valve with or without flow control as options.

Optimised machine operation

The hitch control system of the M5001 allows optimal use of rear implements. The position control controls the attached equipment independently of the required tractive power. The draft control in turn regulates the tractive power required for the machine and automatically reacts to different soil conditions in order to maintain constant traction. Both control methods can also be used together in draft mix.



Highly efficient PTO work

Whether you are cutting grass, baling, or spraying, you can always count on the independent PTO shaft at 540 rpm or 540 Eco rpm, anywhere and anytime. The PTO shaft brake engages automatically when the PTO shaft is disengaged, which brings the implements to a safe standstill. The PTO shaft clutch can be engaged and disengaged electro-hydraulically while in operation. This makes tasks such as mowing or haymaking even more efficient. On request, the tractor can also be equipped with a 1,000 PTO shaft.



#Cab

Get used to lots of room

The Ultra Grand Cab II of the Kubota M5001 offers more space than anyone would expect for the vast majority of tractors in this performance class. The comfortable cab not only provides a unique sense of spaciousness, it also guarantees a pleasant interior environment and excellent panoramic visibility. Climb in and feel at ease. In combination with the newly designed bonnet, the M5001 provides an excellent overview in all directions.



The tractor cab is your “mobile office” for much of the day. Kubota knows how important a pleasant workspace is, which is why the Ultra Grand Cab II of the M5001 has been designed to help you perform your tasks with the utmost comfort and efficiency. With standard equipment such as air conditioning and a skylight window with sunshade, it provides great comfort and high levels of productivity throughout the year.

Easy & convenient entry and exit

Convenience and comfort begin with the doors. The large, continuous glass doors of the M5001 open wide and ensure safe, unhindered entry and exit on both sides—ideal when you are on and off the tractor a lot. The level platform, perfectly positioned pedals, and unobstructed skylight support this concept and provide generous headroom and legroom.

Clear view on all sides

There are very few cabs in this class that provide such excellent visibility of the implements and the immediate working environment. It starts with the fact that Kubota has equipped the cab with curved glass. Not only does this produce less glare, but the glass also provides a feeling of spaciousness and impressive visibility in all directions: the generous glass surfaces, narrow cab pillars, and elegantly sloping bonnet all contribute to this, as does the exhaust pipe positioned at the side of the cab.



Thanks to the all-glass doors, you also have a very good overview of the front implements.

Always under control, even at night

The tractors are equipped with a high-performance lighting package so that the excellent visibility of the M5001 can also be taken advantage of at night. As a result, you benefit from better visibility in the dark and extended work days.



#Cab



Comfortable seating guaranteed

Adjust the cushioned driver's seat according to your preferences. With its high backrest and moveable armrests, it incorporates luxury and convenience, as well as allowing fatigue-free and concentrated work in the field and on the farm. Of course, the M5001 is also available with an air-suspended seat for even greater driving comfort.



Plenty of passenger space

There's also a comfortable spot reserved for an instructor, which is offered as an optional seat. If the instructor seat is not needed, then it can simply be folded down to make more space.

Great climate all year

The M5001 offers complete climate comfort. The standard air conditioning and heating system located underneath the driver's seat fulfils your individual climate preferences. The curved glass and intelligently positioned air nozzles on the steering column circulate the air optimally throughout the cab. You can keep a cool head on hot summer days, as well as being cosy and warm on cold mornings. For your convenience, your Kubota dealer can install an optional electric defogger kit in the M5001. This gives you a clear rear view even in rough weather conditions.

Practical skylight with sunshade

The standard glass skylight lets even more light into the cab. The skylight is particularly useful when working with the fully raised front loader or a pallet fork, for instance. You have a great view of the tools mounted on the front loader without leaving your comfortable seat. In case the sun blinds you during field work or transport trips, it won't do so for long—the retractable sunshade covers the glass skylight to keep the sun at a distance.

The convenience offered by the Ultra Grand Cab II is on a par with the excellent visibility. The comfortable driver's seat and sophisticated cab air conditioning system provide the best conditions for long, pleasant hours on the tractor. See for yourself! You're cordially invited to a long, relaxed work day.



#Cab

You'll gladly take to the wheel in the M5001

The operating concept of the Kubota M5001 is designed for productive work and good ergonomics. As a result, you can concentrate fully on the tasks at hand and achieve optimal results—while remaining relaxed. A steering wheel that gets out of the way.

Did you know?

Did you know that Kubota manufactures products in seven European countries? This proximity to the market is central to the company's philosophy. Each factory adheres to the same high Japanese quality standards, whether it is located in Germany, France, or Japan.





The handy steering wheel can be tilted forward when you exit the cab. Back in the seat, you can move it right back into its starting position. Simply press a pedal. Kubota has optimised the angle of the steering wheel, which gives you better visibility of the instrument panel and towards the front.

Functional platform for greater efficiency

In daily use, every move counts. Kubota has therefore redesigned the cab of the M5001 for improved ergonomics. Almost all central control elements are located right where they belong: ergonomically arranged on the right-hand side next to the driver's seat for easy access. You will appreciate the clear arrangement and their intuitive operation. This allows you to control the implements with precision and to perform loading work with greater ease, while having to move around less in the process. In other words, your work day will be more efficient.

The control elements in the cab ceiling are also easy to reach and adjust. Inspired by the control elements of a passenger car, they are intuitive to use and do not get in the way.



Everything of importance at a glance

Precise information at a glance is the guiding principle of the new, clearly laid out instrument panel display of the M5001. Easy to read and with the same design as its "big brothers"—the Kubota M7001 and the Kubota MGX III—all of the important operating data is available to you in an instant.

Ample storage space

Need room for your thermos flask, cup, notepad, etc.? Take them along! The M5001 offers plenty of storage space.

#Traction

Would you like a little more?

In terms of maneuverability, the Kubota M5001 is in a class of its own. You can see evidence of this whenever things get really tight. The tractor also scores bonus points in traction and ground clearance—further convincing reasons to go with the Kubota M5001.

Did you know?

Gonshiro Kubota founded the company because he could no longer stand to see people dying from contaminated drinking water. He began by manufacturing products for clean water supply. Since then, we have been offering various products that help to improve the living conditions of people and society. That's what "For Earth, For Life" stands for.



The front axle with bevel gear drive makes the M5001 extremely maneuverable, featuring a terrific 55° steering angle. This makes the tractor predestined for jobs in tight quarters. For over 30 years, Kubota has been using front axles with bevel gear drives. For good reason, as this combination is not only responsible for the very tight turning radius, but also allows for the elimination of the high-maintenance universal joints.

Extraordinarily gentle

On account of its front axle, the M5001 offers high ground clearance that is hard to find in this class. Sensitive crops are thus treated more gently when the tractor passes over them. The same is true when making hay or straw, as large swaths remain undamaged.

Enormous tractive power

When dependable tractive power is critical under challenging soil conditions, you can count on the M5001's standard front axle with limited slip differential. It ensures a uniform travel speed, even in the case of slippage. Furthermore, heavier loads can be towed and more grip is available for loading tasks.



Slippage is controlled during turns. Under difficult terrain conditions, you can additionally engage the rear differential lock.

Braking comes easy

All M5001s are equipped with dual brake lines to ensure a great performance in difficult circumstance, for example with a heavier trailer. The M5001 is also equipped with multi-disc brakes running in an oil bath. They require less pedal force, which in turn makes your life easier. Even under recurring tough working conditions, they retain their high performance and braking power.

Four wheel drive easily engaged and disengaged

Engage and disengage the four wheel drive with a simple press of a button. The best part of it is that the tractor doesn't have to be stopped, even when transitioning from the field to the road. This helps your productivity and an LED indicator displays the current status. When the brake is pressed, four wheel drive is automatically engaged for better braking power.

#Front loader

Great visibility towards the front and the top.

Attach and remove the front loader without any tools.

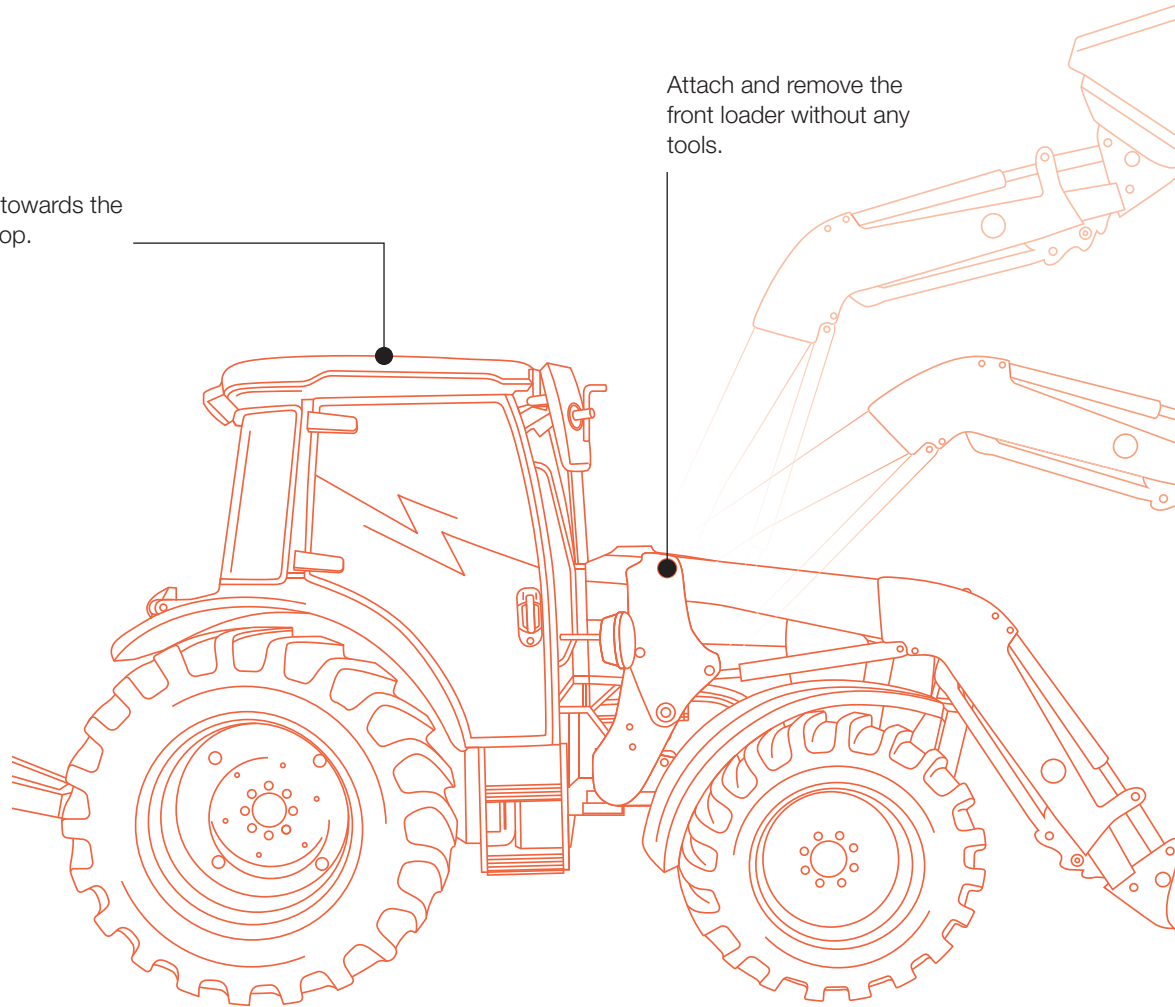

Tractor and front loader: from a single source, perfectly compatible

M5001 plus LA1854 provides a winning formula for perfect compatibility between the tractor and front loader. Both are from the same source—Kubota. You can be sure that everything is optimally matched. See for yourself, in real-world conditions on your own farm.

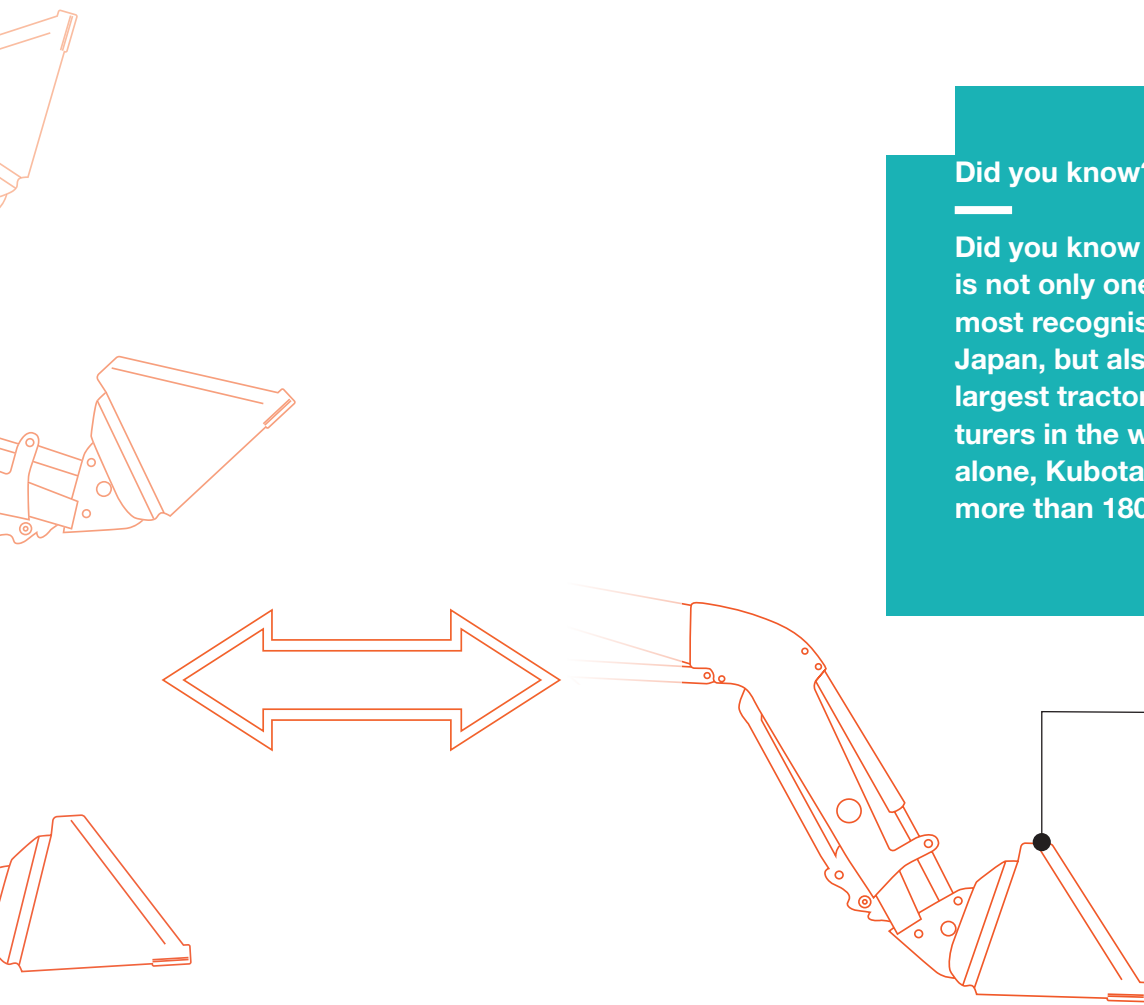

Did you know?

Did you know that Kubota is not only one of the top-50 most recognised brands in Japan, but also one of the largest tractor manufacturers in the world? In 2014 alone, Kubota produced more than 180,000 tractors.

Whether you need to work with a manure fork, pallet fork, bale fork, or a bucket – each of them can be quickly attached and removed from the LA1854 front loader.

The modern designed bonnet provides great visibility towards the front loader or front implement. This ensures a good overall view and safety during your work. Talking about safety, the anti-lowering valves keep the front loader in its position even in cases of hydraulic pressure lost.

Quick couplings that deserve their name

Whether you need to work with a manure fork, pallet fork, bale fork, or a bucket – each one of them can be quickly attached and removed from the M-series front loader. The standard Euro quick coupling is used wherever tools with Euro mounts are attached, heavy loads are handled, and high lift capacity is required. With the optional Kubota quick coupler, you can connect all four or six hydraulic lines at once and disconnect them just as easily.

Great comfort for the driver

The KSR (Kubota Shockless Ride) vibration damping system substantially minimises the shocks experienced by the

driver, which can occur when working on bumpy terrain or during long-distance transport trips, for example. This function can be adjusted or switched on and off using the control below the KSR valve. You can control the front loader with the easy-to-reach joystick on the right-hand side panel of the M5001. Front loader work becomes fast and efficient.

Attach and remove the front loader without any tools

You can attach and remove the front loader without the use of any tools. The integrated supports and two connection pins make doing so a breeze. The benefits are twofold: besides higher productivity, the range of the tractor's applications is extended.

The Kubota LA1854 front loader has various loader options, which surely include the right one for you. With different valve options for the first, second, third, and fourth hydraulic functions, you can increase the number of possible front

loader applications even further, for example with additional hydraulically controlled attachments.

Time is money – save both with the M5001

The agricultural sector has nothing to give away. This is true today more than ever. With the retrofit ISOBUS and Precision Farming solutions for the M5001, you can apply pesticides, fertilizers, and seeds in an efficient, precise, and economical manner. The tractor and productive resources are put to optimal use.



Did you know?

Did you know that Kubota is an ISOBUS pioneer? The Kubota company Kverneland Group invented the ISOBUS technology. And incidentally: Kubota is also leading the industry in AEF certified ISOBUS compatibilities.

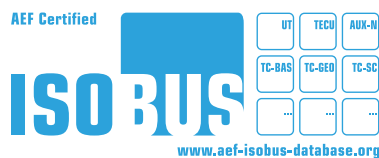



The M5001 can be equipped with retrofit kits, which means that your M5001 becomes an ISOBUS tractor with which you can use any ISOBUS device or machine on the market without limitations. This saves time and money, allowing you to complete your work stress-free.

ISOBUS on board

The terminals are ISOBUS-certified. The connector makes it possible to display the ISOBUS devices in the cab on the IsoMatch Tellus 12-inch or IsoMatch Tellus Go 7-inch monitor. All device settings can be accessed from the touchscreen display by your seat and you can adjust the monitors to your liking.

The two operating terminals are certified according to ISO 11783, the ISOBUS certification for tractors and devices. Up to four cameras can be displayed on one monitor. The terminals have a number of shortcut switches that enable fast and easy switching between screens.

On the IsoMatch Tellus 12-inch, two different screens are displayed at the same time, which means two different pieces of information or even two different ISOBUS machines.

Wide-ranging assistance

In addition to the ISOBUS terminals, a steering LED bar can be used to enable the driver to carry out manual guidance and increase the precision of the M5001.

Efficient use of resources

The GEOcontrol function included in the Kubota terminals, in combination with GNSS receivers, allow you to use the section control application and/or the variable rate function. These functions can be used with ISOBUS implements, such as the precision seeders, spreaders, or sprayers. These functions save costs and resources by saving time, overlaps, fertilizer, and seeds. All jobs with the terminals can be exported to offer perfect traceability.

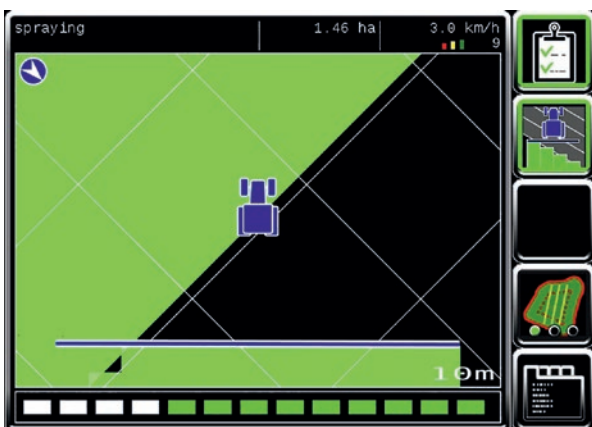

Section control:

With the automatic section control license, the implement is able to manage the opening and closing of the sections by itself. This saves costs and increases driver comfort.

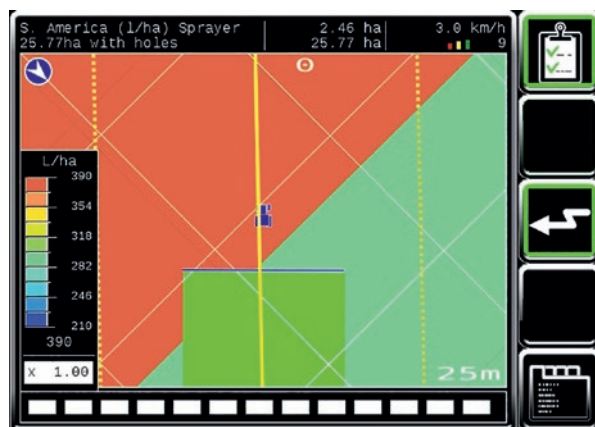

Variable rate:

With the automatic variable rate license, the implement is able to independently manage the rate in combination with prescription maps. This increases the yield per hectare, saves costs and increases driver comfort.

Kubota Farm Solutions: 360° performance for 100% success

We understand that you need more than a powerful tractor to succeed: namely, an integrated system of products and services to increase your competitiveness and preparation for the future. With Kubota Farm Solutions (KFS), we have brought together our solutions in a system—and targeted our proposition to you. From intelligent technology to individual services, the KFS advantages complement each other, forming a circle that ends where it begins: with our commitment to support you a little better every time, now and in the future.

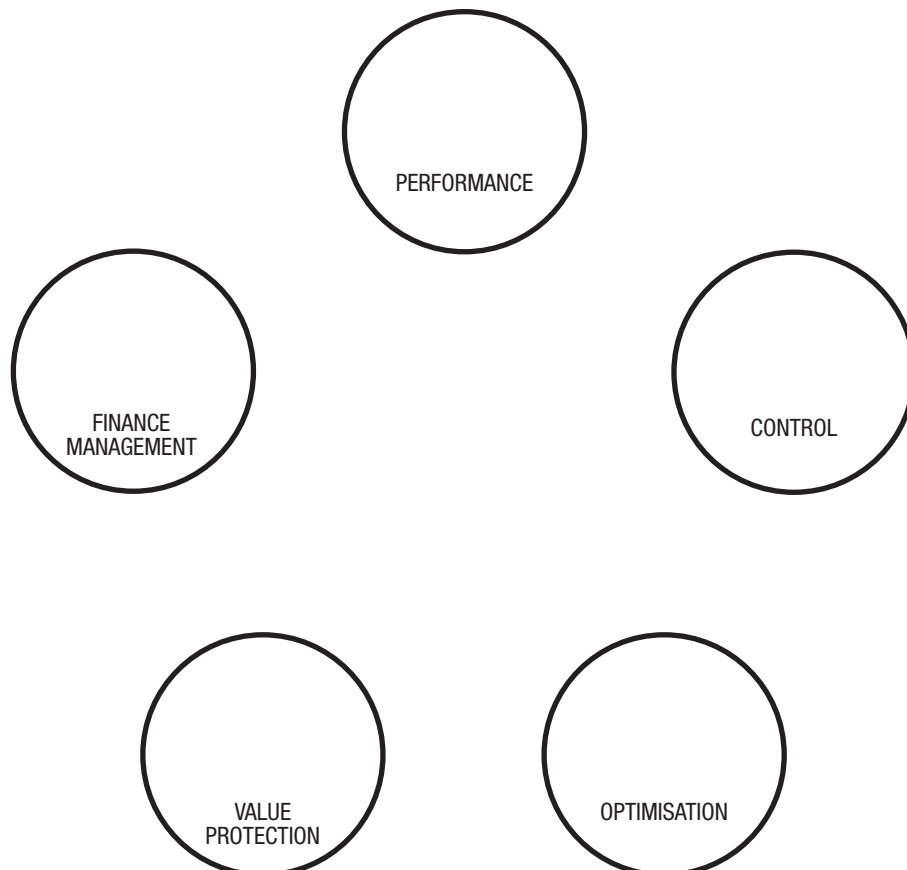

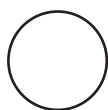

Performance

You have a clear objective: to get your work done productively and successfully while being relaxed. Kubota offers you the equipment that can best support you in this endeavour. Whichever tractor or implements you decide on, you can always count on proven quality, excellent performance, and co-ordinated features. In short: intelligent and reliable technology that gets you a decisive step closer to your goal.

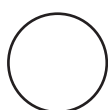

Control

You want full control over what you are doing. Kubota provides you with perfectly integrated systems to help you achieve that. From machine optimisation to implement monitoring, you can control the tractor and resources easily from a single terminal. This not only provides you with a better overview of all work processes, but also allows you to work without stress.

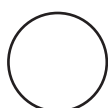

Optimisation

You know exactly how you want to get your work done: efficiently, precisely, and most comfortably. Kubota gives you everything you need to obtain optimal results while remaining at ease. With our ISOBUS technology, precision farming solutions, and automatic steering system, you can apply seeds, fertilisers, and pesticides with extreme precision. This lowers your costs and reduces your workload.

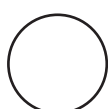

Value protection

You know what it takes to be commercially successful: top performance with every task and top conditions over many years. Once again, Kubota offers solutions that fulfil what they promise. Your Kubota tractor is already protected by 3 year manufacturer warranty right from the start. If you want, you can even extend your warranty to protect the value of your investment, avoid expensive downtimes, and remain profitable over the long term.

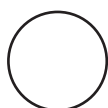

Finance management

You want to improve your productivity, but not at any cost. With Kubota Finance, you can make your planned investment with ease, convenience, and safety. Whether financing or leasing, you benefit from professional advice and attractive conditions. All you need in order to gain the advantages of a technology that drives your success forward. Whether you need machines or services, you have full control of the costs.

Engine Type			3800-TIEF4 (StageIV/DPF+SCR)	
Displacement/No. of cylinders	cm ³		3,769/4	
Rated speed	rpm		2,600	
Engine power output (97/68/EC)	hp(kw)	95 (71)		113 (84)
Fuel Tank capacity/DEF-AdBlue capacity	l		105/12	

Type – Main gear shift			electro-hydraulic shuttle
No. of speeds			36/36 with dual speed
Max. Travelling speed	km/h		40
Range gear shift			3 ranges (H-L-C)
Main gear shift			6 fully synchronised with Hi/Lo
Shuttle shift			microprocessor-controlled electro-hydraulic shuttle
Main clutch			multiple wet disc, electro-hydraulically operated
Brake type			hydraulic discs, 4 wheel braking
4WD engagement			electro-hydraulically
Front Differential lock F/R			limited slip automatic
Rear Differential lock F/R			auto electro-hydraulic

Speed	rpm		540/540Eco; 540/1,000
--------------	-----	--	-----------------------

Pump capacity	l/min		64
3-point hitch category			CAT II Quick hook type
Control system			mechanical (position, draft & mix)
Lift capacity at lift end	kg		4,100
No. of remote valves			2; max. 4
	F/R		480/70R34; 360/70R24

Overall length	mm		4,045
Overall height	mm		2,645
Overall width	mm		2,195
Wheelbase	mm		2,250
Tread width			
	front	mm	1,560–1,660
	rear	mm	1,440–1,790
Turning radius (w/o brake)	m		4.2
Tractor weight	kg		3,420

		Height	Power
Maximum lift height to pivot pin	mm	3,700	3,350
Lift capacity to maximum height to pivot pin	kg	1,810	1,880
Maximum dump angle	deg.	52	64
Roll back force	N	24,470	28,780
Offset from front axle to pivot point at lower position	mm		1,433
Bucket rollback angle	deg.		40
Raising time	sec		4.2
Lowering time	sec		2.9
Bucket dumping time	sec		2.2
Bucket rollback time	sec		2.4



Kubota (U.K.) Limited

Dormer Road Thame, Oxfordshire, OX9 3UN

Website: <http://www.kubota.co.uk>



Every effort has been made to ensure that the contents of this publication were accurate and up-to-date at the time of going to press. All rights reserved. No part of this publication may be reproduced in any form by any means, without prior permission of Kubota. Kubota reserve the right as a manufacturer to amend and update any specification or performance information without notice, if required.